



## **Circulating Air Source Heat Pump Water Heater Owner's Manual**

Models: CH-HP20CMFNM  
CH-HP30CMFNM  
CH-HP40CMFNM

- Thank you for choosing Air Source Heat Pump Water Heater, please read this owner's manual carefully before operation and retain it for future reference.





## Preface

Dear users:

Welcome to use the C&H circulating air source heat pump water heater. Please read carefully the instructions before installation and operation. Install and operate it according to the steps provided in this manual, thus you can master and operate the unit properly.

Please pay attention to the following marks:

 Warning: This symbol indicates the possibility of death or serious injury.

 Caution: This symbol indicates the possibility of injury or damage to property.

 Warning:

(1) Installation work must be conducted by the appointed maintenance center. Improper installations might cause water leakage, electric shock, fire and other accidents.

(2) Be sure not to store or use dangerous materials such as flammable, explosive and poisonous objects near the unit.

(3) Turn off the main power of the water heater immediately upon malfunction (such as combustion is smelled and so on).

(4) Do not insert your fingers or other objects into the air outlet or air-in grille.

(5) Do not start or stop the unit through the way of inserting or pull out power cord.

(6) Do not refit, repair or move the unit. If it needs to be repaired, please contact dealer or professional installer.

(7) Earthing device must be set for hot water unit, heating water tank, thermal storage water tank, water pump and system pipe network.

 Caution:

(1) Before installation, please check whether the power is consistent with that required on the nameplate, and then check the safety of the power.

(2) Before operation, please check and confirm whether electric wires and water pipes are connected correctly for preventing water leakage, electric shock, fire hazard and other accidents.

(3) The power socket must be equipped with earthing wire for ensuring reliable grounding for unit and preventing electric shock. Do not connect earthing wire to gas pipe, tap water pipe, lightning conductor or telephone wires.

(4) Do not operate the unit with wet hands. Do not let children play with the unit.

(5) Turn on or turn off the unit in this instruction manual is turning on or turning off the controller; Cut off the power indicates stop supplying power to the unit.

(6) Do not expose this unit in damp environment directly.

(7) If the outdoor ambient temperature is low in winter, do not cut off the power after stop operation. Otherwise, freeze prevention protection will be invalid.

(8) If the unit won't be used for a long time, please drain the residual water inside unit, water tank and pipeline through drainage valve.

(9) Please conduct leakage inspection after installation.

This appliance can be used by children aged from 8 years and above and persons with reduced physical, sensory or mental capabilities or lack of experience and knowledge if they have been given supervision or instruction concerning use of the appliance in a safe way and understand the hazards involved. Children shall not play with the appliance. Cleaning and user maintenance

shall not be made by children without supervision

	Correct Disposal of this product
 GWP:R410A:2087.5	<p>This marking indicates that this product should not be disposed with other household wastes throughout the EU. To prevent possible harm to the environment or human health from uncontrolled waste disposal, recycle it responsibly to promote the sustainable reuse of material resources. To return your used device, please use the return and collection systems or contact the retailer where the product was purchased. They can take this product for environmental safe recycling.</p>

When there're any problems, please contact dealer, appointed maintenance center or office. You can also contact our company directly.

# Contents

1 Product summary.....	1
1.1 Working principle and applicable areas.....	1
1.2 Principle diagram of system .....	1
1.3 Product features .....	1
2 Unit introduction .....	2
2.1 Outside drawing of unit.....	2
2.2 Parameters table of unit.....	2
2.3 Specification correction table for the unit.....	4
2.4 Schematic plan for the unit outline .....	5
3 Installation requirement for the unit .....	6
3.1 Before installation .....	6
3.2 Position before installation.....	6
3.3 Movement and installation of the unit.....	6
3.4 Installation space .....	7
3.5 Installation of circulating water system.....	8
3.6 Install the water flow switch.....	9
3.7 Construction and installation for the heating water tank .....	10
3.8 System installation diagram and instruction.....	11
4 Electric installation .....	16
5 DIP switch setting on main board.....	20
6 Debugging, daily operation and maintenance .....	22
6.1 Before debugging .....	22
6.2 Test run .....	22
6.3 Daily operation and maintenance.....	23
7 Troubleshooting.....	23
8 Error code .....	25

# 1 Product summary

## 1.1 Working principle and applicable areas

Circulating air source heat pump water heater adopts the heat pump principle, consume some electricity as complement and get the heat through ambient low-grade energy (low-temperature air energy) through thermal circulation. Transmit the heat to condenser through compressor and then release high-temperature thermal source for generating hot water. The working principle is same as that for heat pump air conditioner. The different is that the heat pump air conditioner absorb heat from natural environment and then supply it to indoor air, while heat pump water heater is using this heat to generate hot water. Its EER is at least 3 times higher than conventional electric water heater. Heat pump water heater is a highly efficient, energy saving and environmental friendly product.

This unit is mainly for factory, hotel, restaurant, hospital, beauty parlor, laundry, bath center, large scale floor heating project and so on.

## 1.2 Principle diagram of system

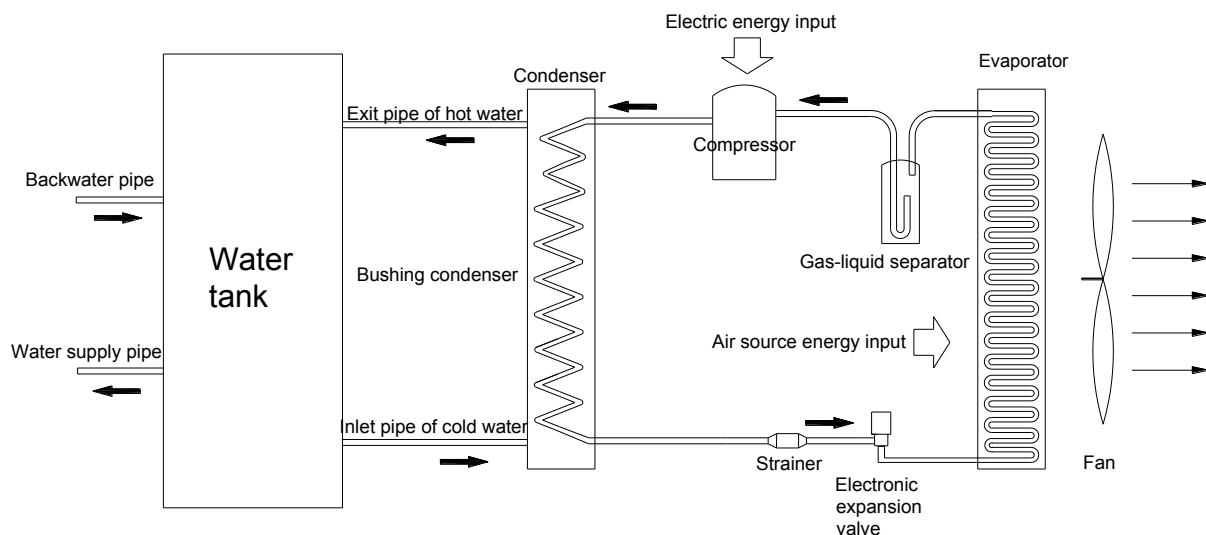

## 1.3 Product features

### ◆ High-efficiency and energy-saving

Adopt heat pump technology, which can transfer the consumed electricity into three times of thermal energy for heat water, high-efficiency and energy-saving. The operation cost is 1/3 of that for electric water heater and 1/3 of that for gas water heater.

### ◆ Safe and reliable

Electricity is only used as the energy for driving medium, while the energy used for heating water is absorbed from the air by medium. Therefore, the heating method is indeed water and electricity separation, safe, stable and reliable.

### ◆ Convenient for installation and convenient for maintenance

The unit can be installed on roof, yard, basement and so on. This unit is with powerful self-diagnosis function, convenient and easy for maintenance.

### ◆ All-day operation and wide application range

This heat pump water heater takes sensible heat and latent heat in air as the low-temperature thermal source, which can provide hot water continuously 24 hours a year and all the year around.

◆ Intelligent control

Microcomputer control.

Chinese interface for displaying the operation status of the unit.

Multiple module network control can control maximum 16 indoor units; parameters for each unit can be set freely; Timer ON and timer OFF control function for each day; perfect protection functions for ensuring reliable operation.

## 2 Unit introduction

### 2.1 Outside drawing of unit



CH-HP20CMFNM  
CH-HP30CMFNM



CH-HP40CMFNM

### 2.2 Parameters table of unit

Model			CH-HP20CMFNM	CH-HP30CMFNM	CH-HP40CMFNM
Hot water mode	Heating capacity	kW	20.22	29.77	40.19
	Heating Power Input	kW	8.52	8.87	13.27
	Heating Current Input	A	13.9	16.9	26
	Nominal Water Output	L/h	602	775	1140
Rated Input		kW	10.1	13.2	19
Rated current Input		A	20	24	38
Set temperature		°C	defaulted at 50°C. 30°C~60°C adjustable (water tank temperature)		
Power			380-415V 3N~50Hz		
Refrigerant	Name		R410A	R410A	R410A
	Refrigerant charge volume	kg	4.2	4.2	5.9
Compressor	Type		Totally-enclosed scroll compressor		
	Quantity	Set	1	1	1
Heat exchanger	Wind side		Finned type heat exchanger		
	Water side		Shell-and-tube heat exchanger		
Fan	Type		Low noise axial flow fan		
	Air discharge type		Top air discharge		

Circulating Air Source Heat Pump Water Heater

	Airflow(ambient temperature 25℃)	m <sup>3</sup> /h	11400	11400	12400
Water system	Circulating Water Flow	m <sup>3</sup> /h	4.8	6.2	9.2
	Water pressure	kPa	70	130	70
	Maximum bearing pressure	MPa	0.8	0.8	0.8
	Diameter of air inlet pipe and air outlet pipe	in	G 1-1/4	G 1-1/4	G 2
Outline dimension	W×D×H	mm	930×800×1605	930×800×1605	1340×800×1605
Packing size	W×D×H	mm	1010×865×1775	1010×865×1775	1420×880×1775
Noise		dB(A)	≤67	≤67	≤67
Net weight		kg	243、242	260、262	358、364

① CH-HP20CMFNM: data in the above table are based on the following test conditions: outdoor ambient temperature: 7℃ DB/6℃ WB; initial water temperature: 50℃; outlet water temperature: 55℃; circulating water flow 4.8m<sup>3</sup>/h; Voltage: 380V 3N~ 50Hz.

CH-HP30CMFNM: data in the above table are based on the following test conditions: outdoor ambient temperature: 7℃ DB/6℃ WB; initial water temperature: 30℃; outlet water temperature: 55℃; circulating water flow 6.2m<sup>3</sup>/h; Voltage: 380V 3N~ 50Hz.

CH-HP40CMFNM data in the above table are based on the following test conditions: outdoor ambient temperature: 7℃ DB/6℃ WB; initial water temperature: 40℃; outlet water temperature: 55℃; circulating water flow 9.2m<sup>3</sup>/h; Voltage: 380V 3N~ 50Hz.

②Applicable range: ambient temperature range is -26℃~46℃.

③The above pressure values all belong to gauge pressure.

④Noise is tested in the semi-silencing room. The actual noise will be a little higher in the actual operation environment.

⑤Circulating water flow means the rated flow during the heating operation. When selecting the water pump model, it shall refer to the flow after overcoming the water resistance, that is, the flow of corresponding delivery lift, rather than the maximum flow labeled in the nameplate of water pump.

⑥The listed water resistance refers to the water resistance under rated working conditions. If the ambient temperature and water inlet temperature are different, unit's hot water output will be changed accordingly, and the water resistance may be different from the listed value.

⑦If the specification is changed due to the product improvement, please refer to the nameplate.

⑧The system reliability and the different water temperature requirement under different water temperature are considered for this product and limit the maximum water tank temperature for stop operation.

The curve is as below:

Curve of maximum water tank temperature for stop operation with the change of ambient temperature					
Ambient temperature/℃	Tank temperature/℃	Ambient temperature/℃	Tank temperature/℃	Ambient temperature/℃	Tank temperature/℃
-26	53	-1	58	24	60
-25	53	0	58	25	60
-24	53	1	58	26	59
-23	53	2	58	27	59
-22	53	3	59	28	58
-21	54	4	59	29	58
-20	54	5	59	30	58
-19	54	6	59	31	57
-18	54	7	60	32	57
-17	54	8	60	33	57
-16	55	9	60	34	56
-15	55	10	60	35	56
-14	55	11	60	36	56
-13	55	12	60	37	55
-12	55	13	60	38	55
-11	56	14	60	39	55



Curve of maximum water tank temperature for stop operation with the change of ambient temperature					
Ambient temperature/°C	Tank temperature/°C	Ambient temperature/°C	Tank temperature/°C	Ambient temperature/°C	Tank temperature/°C
-10	56	15	60	40	54
-9	56	16	60	41	54
-8	56	17	60	42	54
-7	57	18	60	43	53
-6	57	19	60	44	53
-5	57	20	60	45	53
-4	57	21	60	46	52
-3	57	22	60		
-2	58	23	60		

## 2.3 Specification correction table for the unit

model	Water inlet temperature(°C)		Circulating water flow 4.8m <sup>3</sup> /h, Outdoor ambient temperature( wet/dry bulb °C)							
			-20	-15	-7/-8	7/6	20/15	30/22	35/24	46/28
CH-HP20CMFNM	Heating Capacity (kW)	50	9.94	11.13	13.35	20.22	27.93	30.91	31.67	37.52
		40	10.24	12.26	14.63	21.77	28.00	33.81	34.08	38.92
		30	10.34	12.48	15.50	22.53	28.65	35.82	34.58	39.32
	Heating Power Input(kW)	50	7.94	8.03	8.15	8.52	7.63	8.66	8.63	8.95
		40	6.63	6.76	6.89	7.28	7.51	7.82	7.27	7.54
		30	6.22	6.46	6.62	6.95	7.49	6.76	7.20	7.31
	Coefficient of performance(W/W)	50	1.25	1.39	1.64	2.37	3.66	3.57	3.67	4.19
		40	1.54	1.82	2.12	2.99	3.73	4.32	4.69	5.16
		30	1.66	1.93	2.34	3.24	3.83	5.30	4.80	5.38

model	Water inlet temperature(°C)		Circulating water flow 6.2m <sup>3</sup> /h, Outdoor ambient temperature( wet/dry bulb °C)							
			-20	-15	-7/-8	7/6	20/15	30/22	35/24	46/28
CH-HP30CMFNM	Heating Capacity (kW)	50	12.51	14.00	15.04	26.99	34.89	38.16	38.38	43.27
		40	12.70	14.62	18.70	27.73	36.08	41.68	40.41	44.32
		30	12.81	15.46	20.76	29.77	39.15	44.85	43.48	47.07
	Heating Power Input (kW)	50	9.39	9.49	9.62	11.06	11.12	10.91	11.06	11.41
		40	7.85	8.00	8.35	9.29	9.46	9.38	9.49	9.73
		30	7.34	7.63	8.12	8.87	9.25	9.68	9.26	9.56
	Coefficient of performance (W/W)	50	1.33	1.48	1.56	2.44	3.14	3.50	3.47	3.79
		40	1.62	1.83	2.24	2.98	3.81	4.44	4.26	4.55
		30	1.74	2.03	2.56	3.35	4.23	4.63	4.70	4.92

model	Water inlet temperature(°C)		Circulating water flow 9.2m <sup>3</sup> /h, Outdoor ambient temperature( wet/dry bulb °C)							
			-20	-15	-7/-8	7/6	20/15	30/22	35/24	46/28
CH-HP40CMFNM	Heating Capacity (kW)	50	17.72	19.84	21.31	38.25	49.44	54.08	54.39	61.32
		40	17.88	21.19	27.11	40.19	52.3	60.42	58.57	64.25
		30	17.97	21.69	29.12	41.76	54.92	62.91	61	66.03
	Heating Power Input (kW)	50	13.41	13.55	13.74	15.79	15.88	15.58	15.79	16.3
		40	11.21	11.42	11.92	13.27	13.51	13.4	13.55	13.9
		30	9.2	9.56	10.17	11.12	11.59	12.13	11.6	11.98
	Coefficient of performance (W/W)	50	1.32	1.46	1.55	2.42	3.11	3.47	3.44	3.76
		40	1.60	1.86	2.27	3.03	3.87	4.51	4.32	4.62
		30	1.95	2.27	2.86	3.76	4.74	5.19	5.26	5.51

## 2.4 Schematic plan for the unit outline

CH-HP20CMFNM

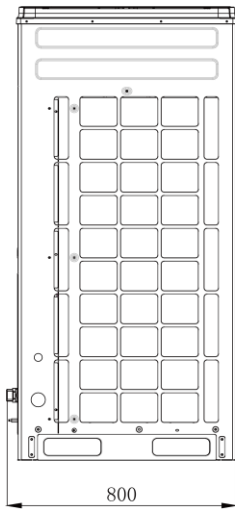

CH-HP30CMFNM

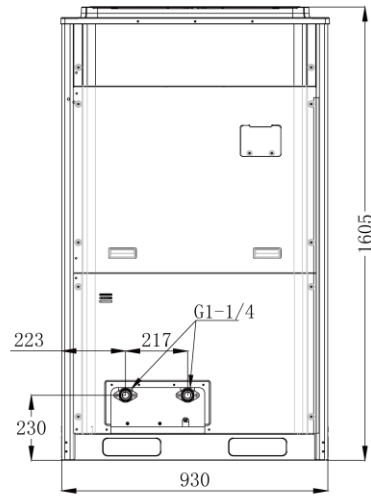

Unit: mm

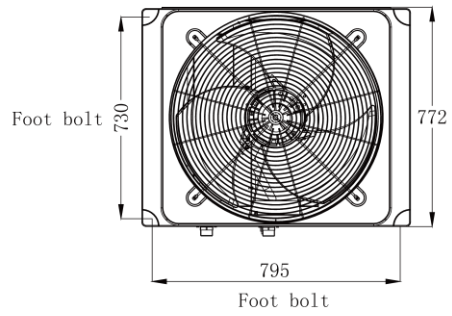

CH-HP40CMFNM

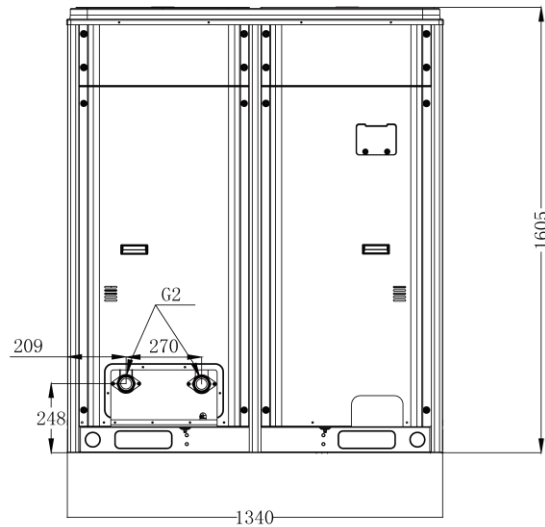
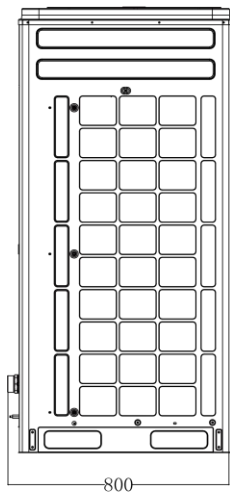

Unit: mm

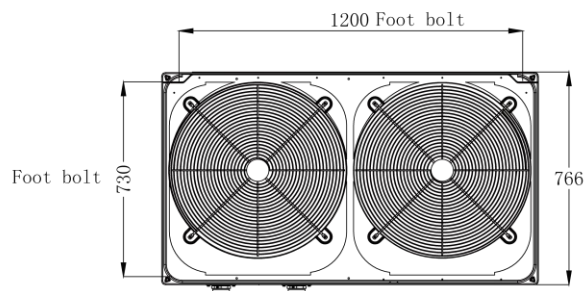

### 3 Installation requirement for the unit

#### ⚠ Caution:

- (1) Improper to operate the unit at the places where there's strong magnetic field, much salt and alkali, high acid and unstable voltage.
- (2) Confirm the correct transmit path and method for preventing damage and accident.
- (3) Confirm whether the installation base is solid. When this unit is installed at the metal part of the building, it must be electric insulated and comply with related technical standard.
- (4) Please make sure the installation position is far away from the storage areas of inflammable and explosive objects to prevent explosion or fire hazard.

#### 3.1 Before installation

Before installation, the user should open the carton box to check the unit:

- (1) Check whether all documents and accessories are complete according to the packing list.
- (2) Check the model and specification of the unit basing on the attached documents.
- (3) Check whether the unit is in good conditioner and whether the accessories are complete.
- (4) Check there's refrigerant leakage.
- (5) If there's damage or problems, please contact appointed local office of our company in time.

#### 3.2 Position before installation

- (1) The unit can be installed on balcony, roof, special flat form or any other places where's convenient for installation and bear the weight of the unit.
- (2) The unit should be installed the well-ventilated place, and avoid the air discharge and noise disturb other people. Please pay attention to the wind direction and avoid the strong wind.
- (3) When placing the unit on the roof, please pay attention to the wind direction to prevent strong wind.
- (4) There should be no strong thermal source, discharge outlet of other equipments, hot steam and inflammable gas around the unit.
- (5) There should be discharge ditch or discharge outlet nearby the installation position of the unit.

#### 3.3 Movement and installation of the unit

Every unit has been conducted strict test and inspection before ex-factory for ensuring its specification and quality. User must be careful during installation and movement to avoid damaging the control system and pipeline parts.

- (1) Please adopt fork truck or crane for movement.
- (2) Use the canvas gallus or the wire cable with enough strength ( $> \Phi 10$ ) for handing the unit. Wind the base of the unit with the canvas gallus or the wire cable and then bundle it tightly, and add protective gasket at the contacting position between the canvas gallus or the wire cable and the unit for preventing damage to the unit. When moving the unit, the inclined angle should be less than  $15^\circ$  and the unit should be moved carefully.
- (3) After movement is finished, please remove the underlaid gasket, gasket of compressor.

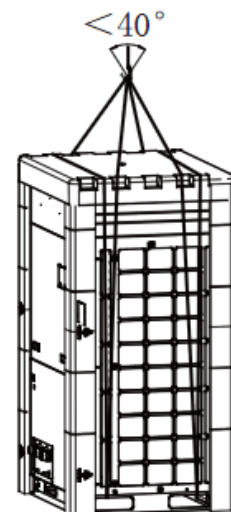

(4) During installation, use M12 expansion bolt to fix the unit at the independent concrete base. You can use angle iron or channel steel to make the steel bracket, adding vibration-proof rubber gasket, and then place it on the ground or roof. Please confirm that the unit is placed horizontally. See below fig.

(5) In case that the water heater is not under the lightning protection of the building, then lightning protection measures should be taken according to the existing local national standards.

### 3.4 Installation space

(1) Single unit installation space for CH-HP20CMFNM, CH-HP30CMFNM, CH-HP40CMFNM

Unit: mm

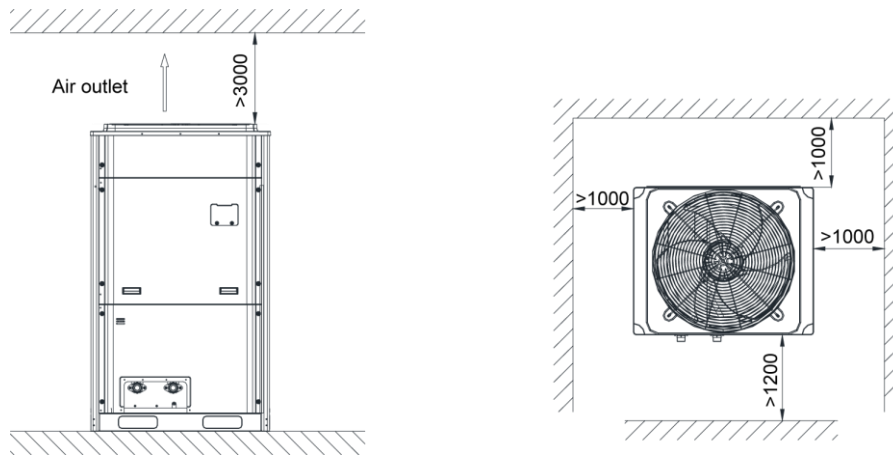

(2) Modular unit installation space for CH-HP20CMFNM, CH-HP30CMFNM, CH-HP40CMFNM

Unit: mm

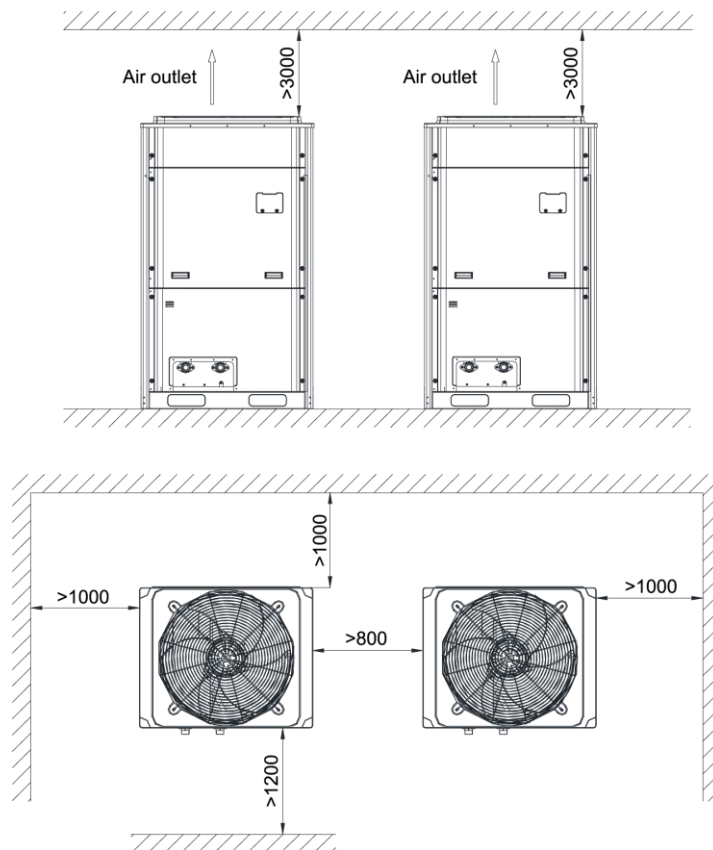

### 3.5 Installation of circulating water system

(1) Water system design and construction must be complied with the water-heating design regulation and related standard requirement.

(2) The unit adopts water flow switch as the cut-off protection, which is not equipped with the unit. Users should install it by themselves. Meanwhile, please ask project installer to adjust the cut-off point.

(3) The pipe diameter for water outlet and water inlet of the unit should be decided by the rated flow volume and suggested flow speed of the unit. You should try to reduce the resistance of the water system as much as possible.

Below is the flow speed for the hot water pipe:

Suggested value for the slow speed of the hot water pipe

Diameter (mm)	15~20	25~40	≥50
Flow speed (m/s)	≤0.8	≤1.0	≤1.2

(4) When connecting the water pipe, please use PPR pipe to connect it to the water outlet and water inlet, and then connect it to the external water pipe.

(5) Water pipe and valve: For ensuring the water system clean, PPR pipe materials should be adopted. The common valves are cut-off valve, ball valve, check valve, shutoff valve, and so on. Copper core valve should be adopted. Adopt rubber belt for the thread airproof between valve and connection pipe to prevent polluting pipeline.

(6) Water pipe should be installed horizontally and reasonably. Try to reduce elbows as much as possible for decreasing the resistance of water system.

(7) Water pipe must be thermal insulated to prevent heat loss. The common thermal insulation materials are PEF, glass cotton, rubber insulation sponge, etc.

(8) Thermometer and water pressure gauge should be installed at the water inlet pipe and water outlet pipe of unit for inspection during operation. You are suggest to adopt 0~100℃ glass thermometer and 0~1.6MPa water pressure gauge. Install the strainer at the water inlet position of unit to prevent blockage of tubing heat exchanger and clean it periodically.

(9) In general, the service valve should be installed in front of the electric solenoid valve on the system pipeline for future maintenance. For the convenient of cleaning system, blow down valve should be installed at the lowest position of the system.

(10) The water makeup valve and cut-off valve for the system may need to be thermal insulated in winter to prevent breakage due to low temperature.

(11) After the pipes for the water system is installed well, conduct water leakage and blowdown test according to related regulations to prevent damage to pipeline, tubing heat exchanger and water pump.

(12) If the ambient temperature is very low in winter, no need to cut off the power after stopping operation. Otherwise, the freeze prevention protection may be invalid. If the unit won't be used for a long time, please drain out the residual water inside the unit, the water tank and the pipeline through the drainage valve.

### 3.6 Install the water flow switch

The water flow switch is used for measuring water flow of the circulating water side. When the circulating flow reaches its closed flow, it is used to output closed loop circuit; and when water flow is smaller than a certain flow, water flow switch will send out a break-off signal to stop the units and thus protect compressor, water pump and other important components.

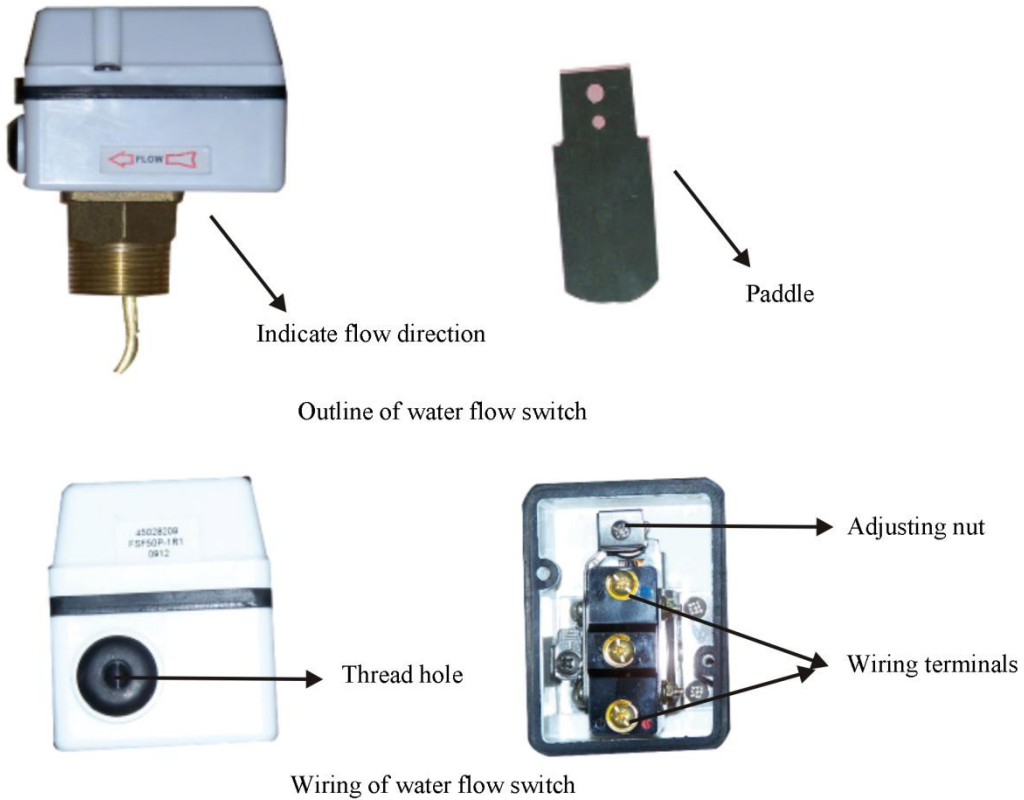

(1) Usually water flow switch contains detachable paddles that are 45mm, 65mm, 75mm or 85mm's long and 16mm's wide. The paddle can be trimmed conditionally during installation. Please make sure the rear part forms an arc that matches the pipe and the bottom of the paddle should be 10%-20% above the pipe central line, thus avoiding collision between the paddle and the inner surface of pipes as well as other objects inside.

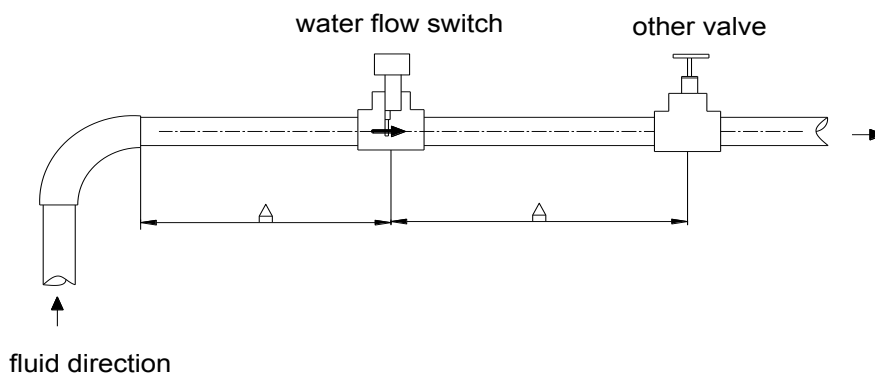

Installation diagram for the water flow switch

(2) Please make sure that the flow direction is consistent with marks on the water flow switch box cover;

(3) Water flow switch should be installed on horizontal pipes, and make sure that size of A in above diagram is at least 5 times larger than pipe caliber;

(4) The wiring distance between the water flow switch and the units should be less than 10m, and the water flow switch should be installed at a position where wiring is easy;

(5) Water flow switch project should be added by rain-proof equipment (Rainproof cover should be set up);

(6) Water flow switch installation size is "G1".

### 3.7 Construction and installation for the heating water tank

Installation diagram of water tank:

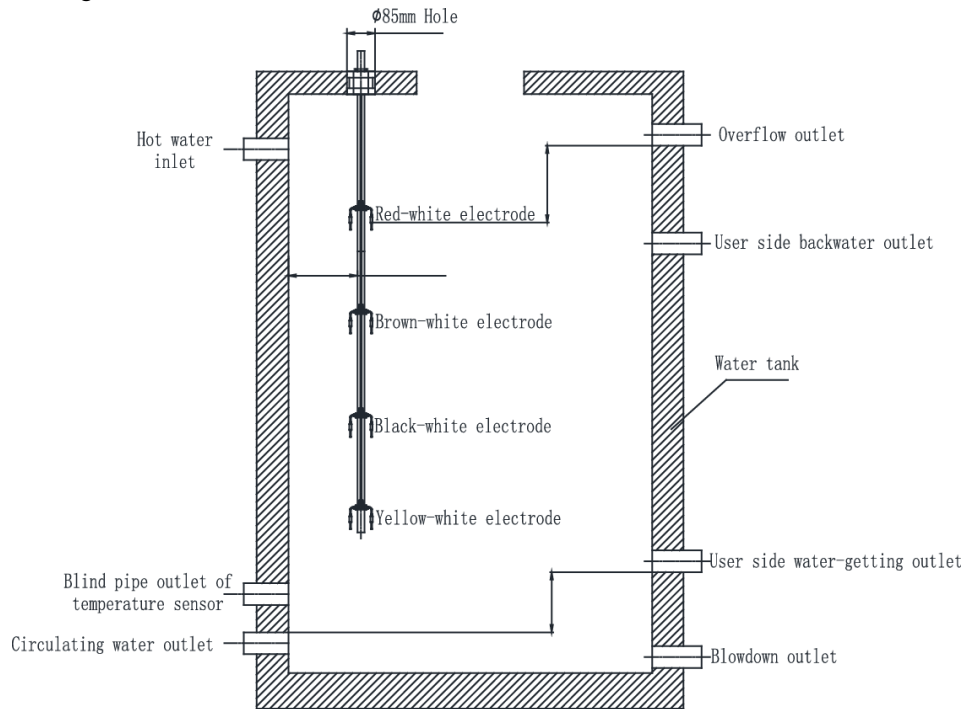

Installation diagram of water tank

The installation of water tank is mainly for the matching between water tank and pipeline and the matching among water level switch. Please pay attention to below point during installation:

(1) The water-getting outlet of user should be 50mm (minimum) higher than the circulating water outlet to prevent water-lacking during operation.

(2) The overflow port should be 50mm (maximum) higher than the water level switch to prevent overflow of water tank. The overflow port must be connected with connection pipe and then lead it to the flow drainage outlet;

(3) The hot water inlet and the user back water outlet should point at the water level switch to prevent impacting of water flow and then cause wrong action of switch.

(4) If the auxiliary electric heating is installed on the water tank, the position of the auxiliary electric heating should be lower than the user water-getting position.

(5) Water temperature sensor must be installed under the user water-getting outlet, and it should be placed into the blind pipe.

(6) The valid volume of water tank must be ensured. The valid volume of water tank is the volume between the user water-getting outlet and the high water level.

### 3.8 System installation diagram and instruction

#### 3.8.1 Hot water project

(1) Installation diagram for signal unit system

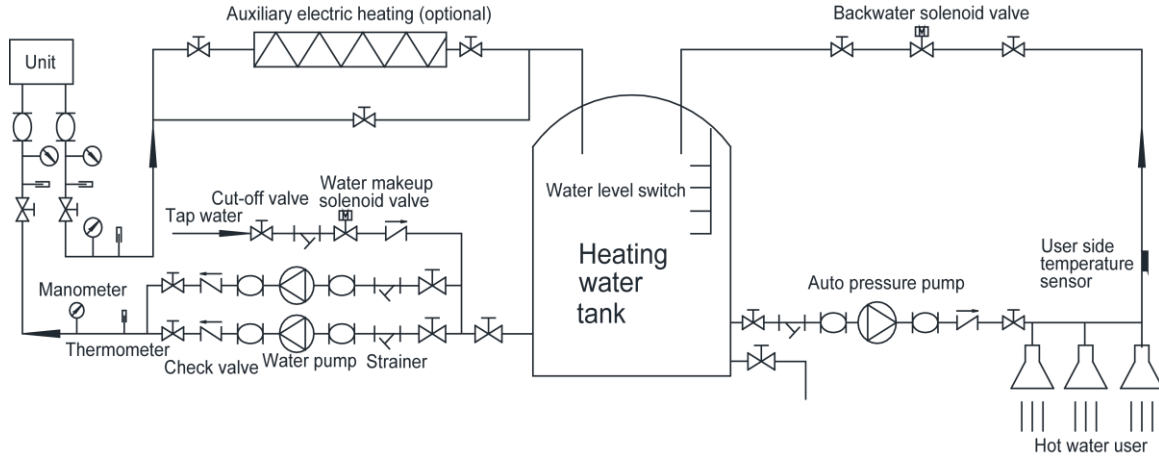

Fig1 Timer water supply installation diagram for single unit

(2) Installation diagram for modular system

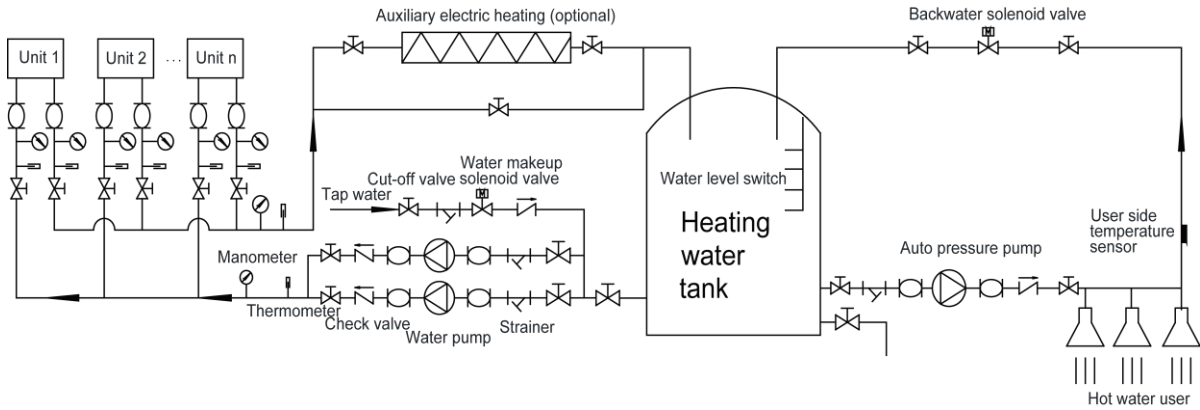

Fig2 Timer water supply installation diagram for modular series

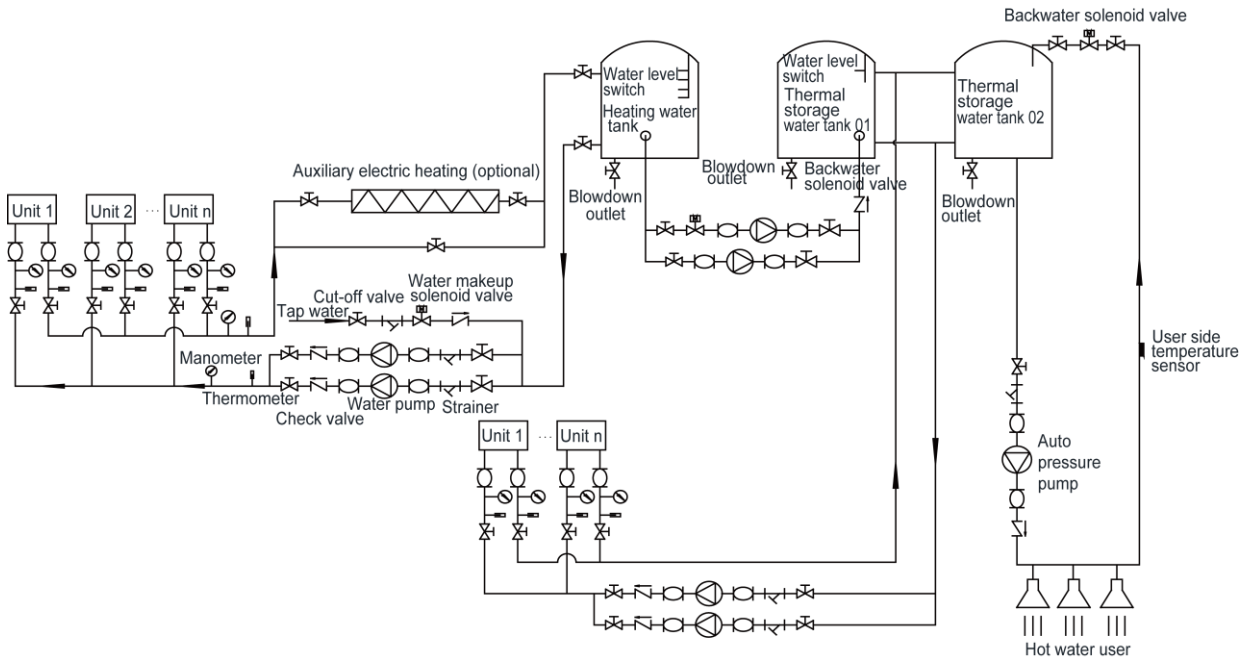

Fig3 Non-timer water supply installation diagram for modular unit (the height of heating water tank is same as that of hot water storage tank)



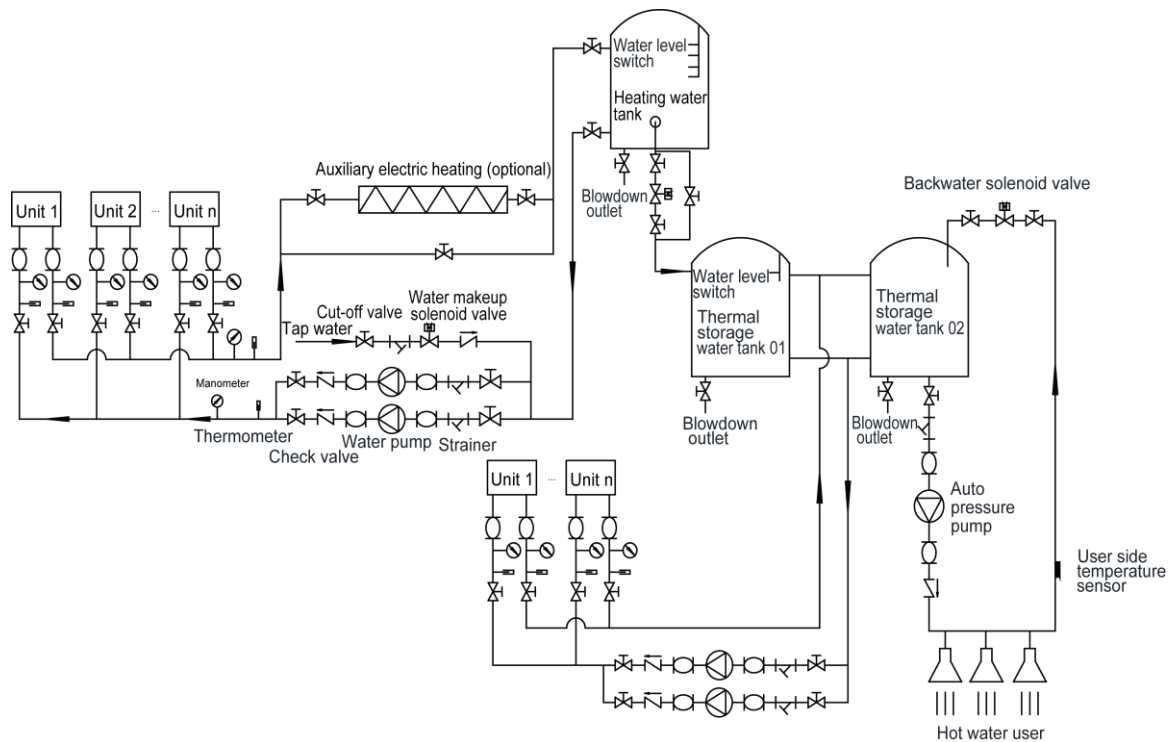

Fig4 Non-timer water supply installation diagram for modular unit (the heating water tank is higher than heat storage water tank)

1) Makeup water control: When the water level inside the water tank is lower than the low water level, the water makeup solenoid valve will be started to make up water; when the water level reaches the high water level, the water makeup solenoid valve will be turned off. For the first time water makeup before operation, water can be made up into water tank directly. During operation, the water will make up automatically from the water inlet of heating unit.

2) Instruction for heating operation: When the hot water temperature inside the water tank is lower than a certain temperature below the set temperature, the unit will be started up. The hot water circulating pump will let the water inside the hot water tank; when the water temperature inside the water tank reaches set temperature, the unit will stop operation.

As for the project with thermal storage water tank, if the water level switch of thermal storage water tank is lower than the low water level, the water discharge solenoid valve (water discharge pump) between heating water tank and thermal storage water tank will be started up, and then fill the thermal storage water tank with water. If the water level switch of the thermal storage water tank is at the high water level, the water discharge solenoid valve between heating water tank and thermal storage water tank (water discharge water pump) won't act and it won't fill the thermal storage water tank with filter.

3) Parallel connection quantity of unit  $1 \leq n \leq 16$ .

4) The heating water tank and the thermal storage water tank must be insulated.

5) As for the heat supply system of modular system with timer function, if the water consumption volume is not big and not frequently, it's no need to set thermal storage water tank in the project (fig 2); as for the non-timer heat supply system, if the water consumption volume is big and frequently, it's required to set heating water tank and thermal storage water tank. In general, one heating water tank is ok; while there should be one or more thermal storage water tank according to the actual circumstances for satisfying water consumption requirement at any time. At present, there are two kinds of setting method for heating water tank and thermal storage water tank: one setting method is contour setting,

that's the heating water tank and the thermal storage water tank are set at the architectural plane. Water discharge water pump should be set between thermal storage water tank and heating water tank for sending the heated water to the thermal insulating water tank (see fig 3). The other setting method is the non-contour setting, that's the heating water tank is higher than the thermal storage water tank. The heated water can be send to the thermal insulating water tank by the gravity of water and it's no need to set water pump (fig 4). The second setting method is suggested for the project.

6) When users don't use the hot water for a long time, the water temperature inside the thermal storage water tank will decrease due to the heat loss. It needs to set thermal insulating unit on the project. When the water temperature inside the thermal storage water tank is lower than a certain temperature below the set temperature (user can set the temperature by themselves), and thermal insulating unit will be started up and heat the water inside the thermal storage water tank. When the water temperature reaches to set temperature, the thermal insulating unit will stop operation. The detailed quality is decided by the actual circumstances.

7) Back water control of water system at user side: When the water at the user side hasn't been consumed for a long time, the water temperature inside the water pipe will decrease. When the water temperature is decreased to set temperature (20~50°C adjustable), backwater pump or backwater solenoid valve will be started up to heat water or suck the hot water inside the thermal storage water tank into pipe network to increase the water temperature. When the water temperature is increased to a certain temperature above set temperature, backwater pump or backwater solenoid valve will be stopped for ensuring the water temperature requirement.

If user has requirement for water supply pressure. Users are suggested to adopt water pump + electric contact type pressure switch. When the water pressure is lower than set value, the water pump will be started up; when the pressure reached to set value, the water pump will stop operation. When user is using water, the user water supply water pump will be controlled by the by electric contact manometer or water flow switch (equipped by project). Meanwhile, they will send the power-off command to backwater solenoid valve.

#### 8) High/low water level requirement for water level switch

The high water level of water level switch for the heating water tank should be lower than the overflow pipe (generally, on top of the water tank) of the heating water tank. The low water level should be a little higher than the pipe inlet of unit at the circulating heating side.

#### 9) Water system instruction at user side

If the system pipeline is short and the pipe network is simple, user can supply water by the gravity of water, no need to adopt water pump circulation. You can also adopt the water pump circulation system as shown in fig 3 and fig4. If the water hasn't been used for a long time, the water temperature inside the water pipe will decrease. When it's decreased to a certain temperature below the set temperature, water supply water pump will be started up to compress the hot water inside the thermal storage water tank into pipe network for increasing the water temperature.

10) Control of auxiliary electric heating: The auxiliary electric heating adopts pipeline electric heating, which is controlled by ambient temperature and the unit.

#### Special hint:

If the unit hasn't been used for a long time or the unit is started up for the first time, please check the

heating water tank. Fill the heating water tank with water and then turn on the unit.

For the heat supply system with timer function, if the water inside the water tank hasn't been used up within one day, users are suggested to turn on the electromagnetic water makeup valve to fill the water tank with water before operating the unit for the second day.

### 3.8.2 Swimming pool project

#### (1) Installation diagram for the single unit system

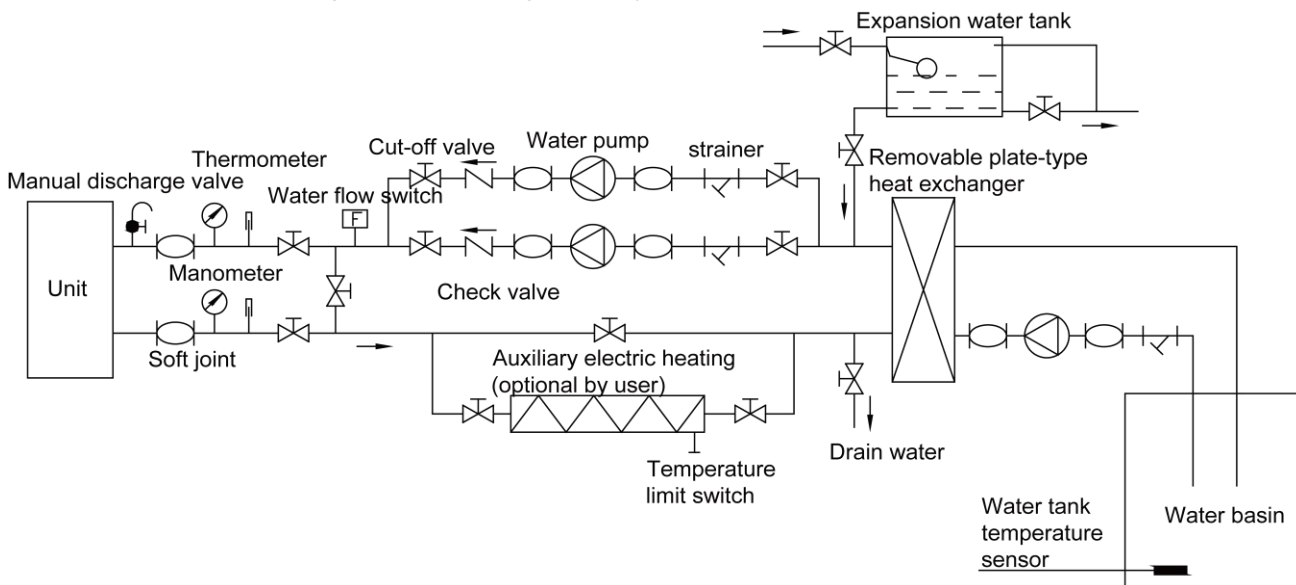

#### (2) Installation diagram for the modular system

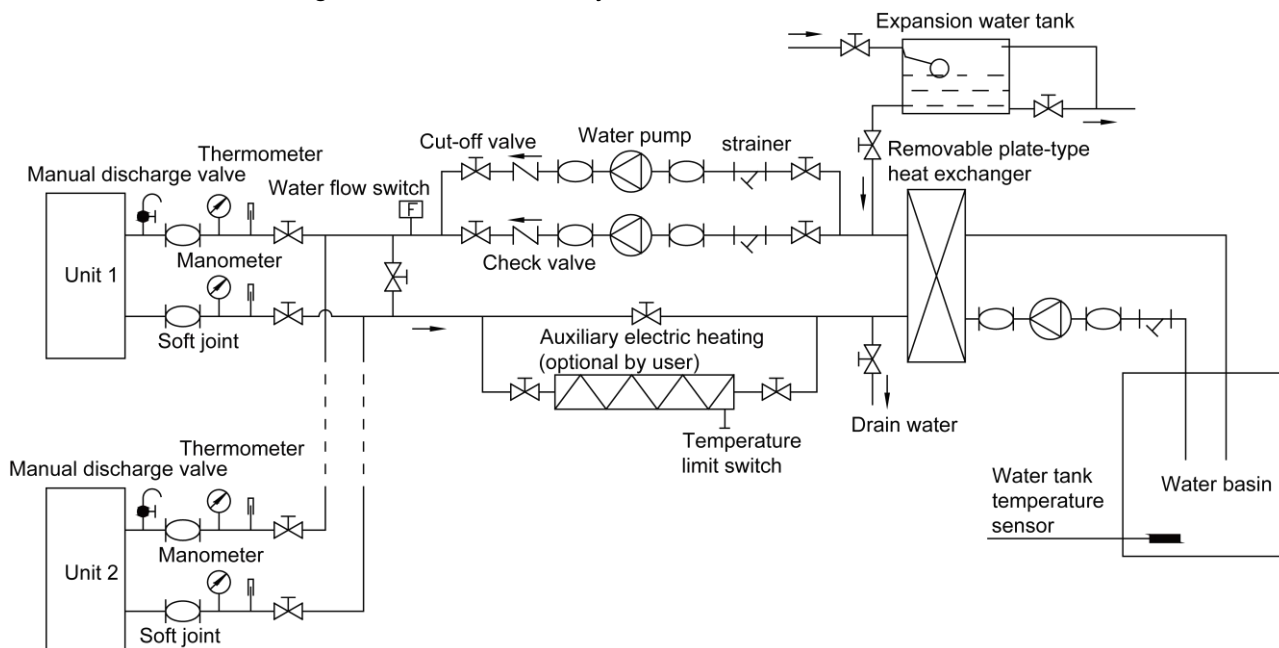

Installation principle instruction :

1) In order to prevent water freezing in the water side heater exchanger and pipeline, add ethanol and propyl alcohol in water. However, prohibit adding salt into water for preventing corrosion and damage to the unit. The water side heat exchanger inside the unit can't comply with the anti-corrosive requirement for swimming pool. Therefore, please do adopt intermediate plate for the second heat-exchanging method for swimming pool project.

2) In order to prevent frequent ON/OFF of the unit due to low load, and below 0°C water

temperature during defrosting period, if the swimming pool system is frequently operates under low load, please make sure the water capacity of the system is more than the 1/6 of the total rated flow volume per each hour for every modules. If the waterway is short, it needs to add water storage tank. Otherwise, it may affect the service life of the unit.

3) Instruction for water makeup: When the water level inside the expansion water tank, the water makeup valve will open to make up water; when the water level reaches a certain water level, the water makeup valve will be closed.

4) Instruction for heating operation: When the water temperature in the swimming pool inspected by water tank temperature sensor is decreased to a certain temperature below set temperature, the unit will be started up and the unit side circulating water pump will make the water inside the pipe network pass through the water side heat exchanger and then heat it circulate. Meanwhile, swimming pool side circulating water pump will make the water inside the swimming pool pass through removable plate-type heat exchanger for the second time heat-exchanger. When the water temperature in the swimming pool reaches the set temperature, the unit will stop operation. Because swimming pool system is the second time heat-exchanging, there's temperature difference of heat-exchanging at unit side and swimming pool side. When setting the temperature value of temperature sensor for water tank, please try to set it 10°C above lower than the maximum set temperature.

5) Parallel connection quantity of unit  $1 \leq n \leq 16$ .

6) Water pump control: because the water inside pipe network and swimming pool should be heat exchanged simultaneously, please make sure the water pump at unit side and the water pump at swimming pool side are controlled simultaneously during installation.

7) Control of auxiliary electric heating: The auxiliary electric heating adopts pipeline electric heating, which is controlled by ambient temperature and the unit.

8) If the unit hasn't been used for a long time or the unit is started up for the first time, please check the pipe network and clean it. Fill the pipe network and expansion water tank with water and then turn on the unit.

## 4 Electric installation

 Warning: Water heater must be grounded reliably. Incorrect grounding may cause electric shock or fire hazard.

 Caution: All electric work must be conducted according to local law, regulation and instruction manual by professional person.

 Caution: If the wiring is changed due to improvement of product, please refer to the wiring diagram on the unit.

 Caution: For the consideration of safety, the leakage protection device at the power side. The detailed position is as shown in below fig:

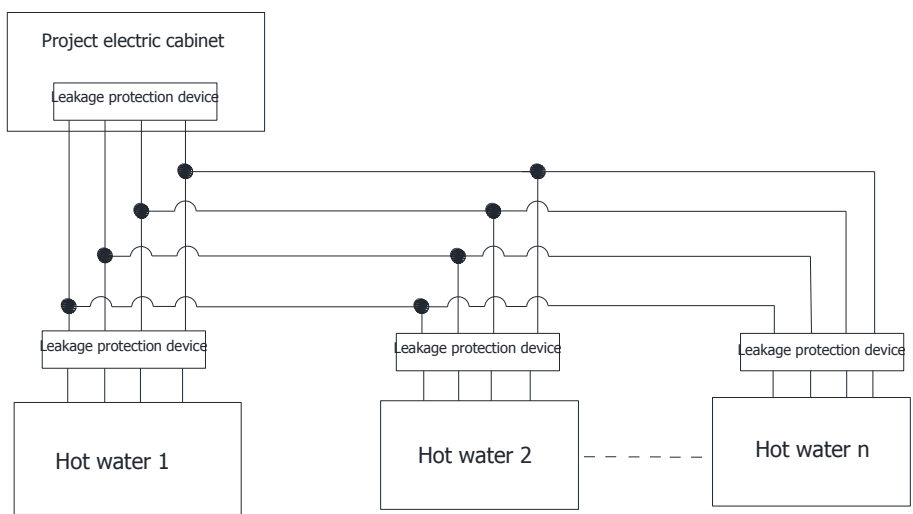

(1) Master module

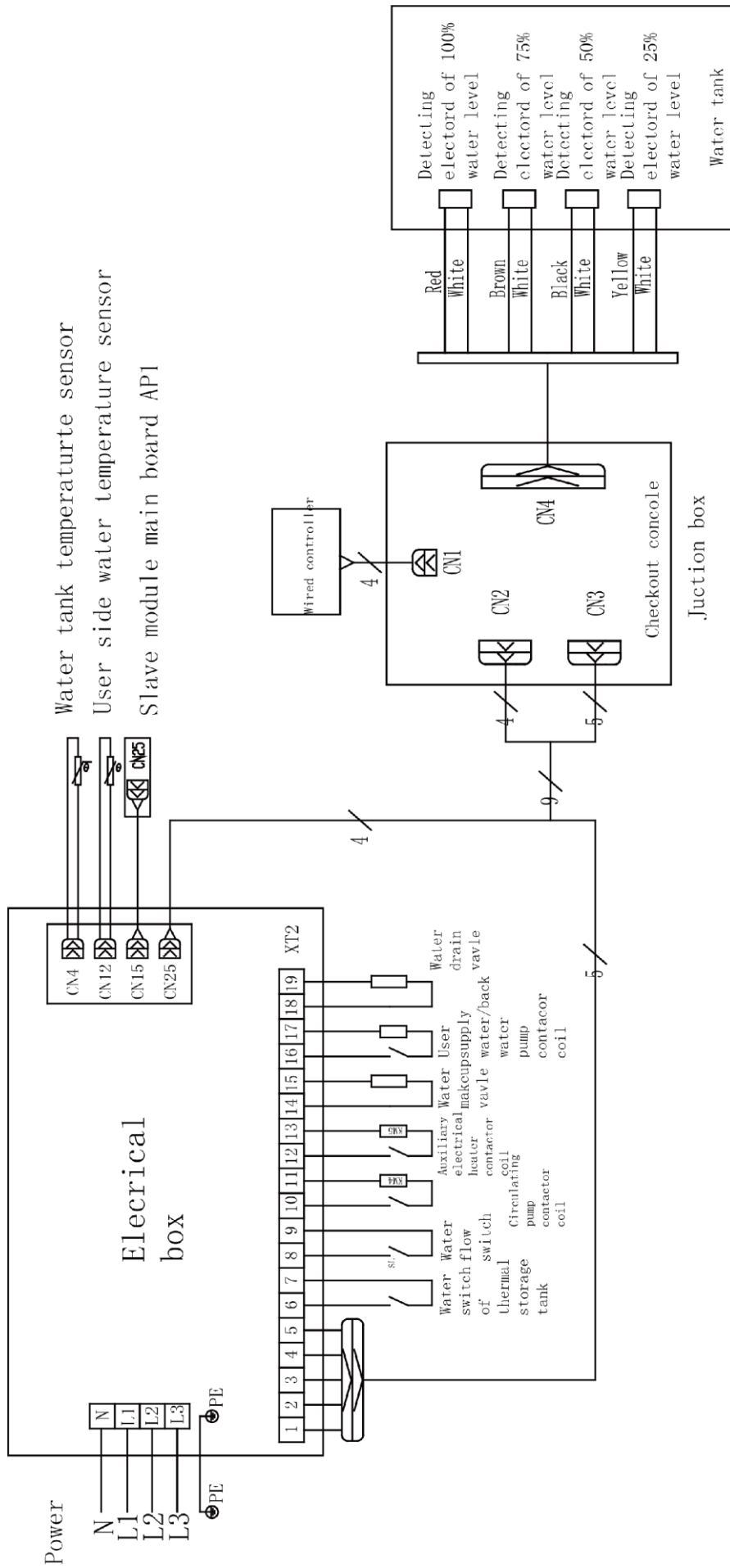

Remark: Connect No.4 switch (SW4) , No.3 switch (SW3) , No.2 switch (SW2) , No.1 switch (SW1) , water flow switch, circulating water pump, supply/back water pump, temperature sensor of water tank, user side temperature sensor top master module; no need to connect slave module. Under floor heating mode, it's no need to connect water-level switch.

Note: When connection wires between the main unit and the water tank are used, please add wire-passing pipe or wire groove for protection to reach the same protection requirement with polychloroprene sheathed flexible cord (IEC60245 57# wire). When installing the temperature sensor wires, please fix it with wire clamp. The fixation of the wire clamp can let the temperature wire support 100N tension force.

(2) Slave module

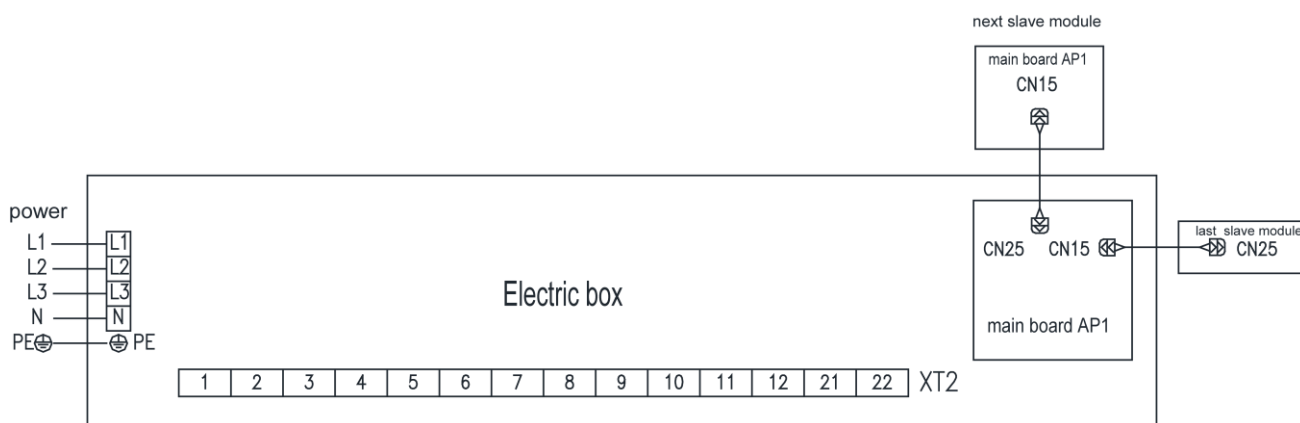

(3) Connection among modules

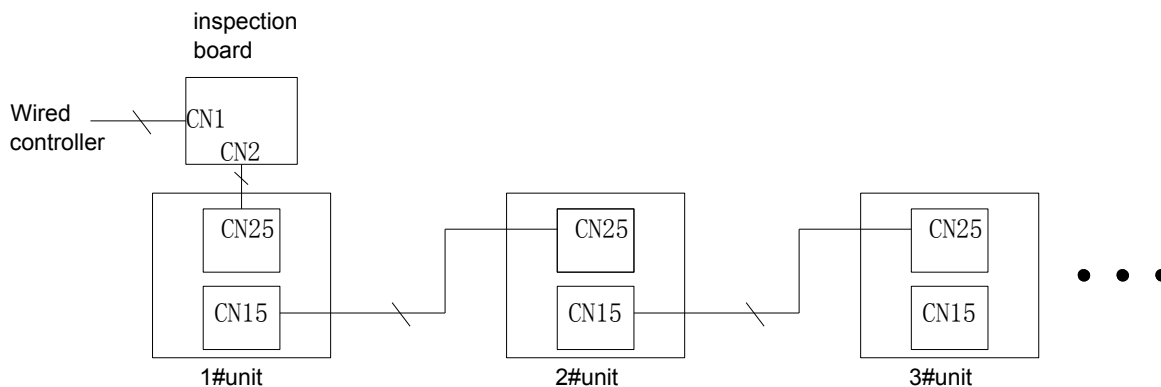

(4) Wiring layout

If the supply cord is damaged, it must be replaced by the manufacturer, its service agent or similarly qualified persons in order to avoid a hazard.

Disconnect the power supply before cleaning and maintenance.

- 1) The unit should be installed according to national wiring regulation.
- 2) Rated voltage and the special power for the air conditioner must be adopted.
- 3) Power cord should come along the wire-passing groove or wire duct.
- 4) When connecting the power cord to the electric cabinet of unit, it must be protected with rubber or plastic to prevent damage.
- 5) The specification of conducting wire should be 1mm<sup>2</sup> or above.
- 6) The signal for connecting the water-level switch is DC weak current. Do not come along with the

conducting wire with 50V or above. If it can't be avoided, the distance between weak current signal and strong current should be kept 150mm above.

7) Reserve proper amount of control wire which is entering into the unit. Do not bundle residual electric wire and then insert it into the electric cabinet.

8) The power cord should be fixed reliably.

9) User must install the air switch and the leakage switch which can cut off the power for the complete system at the power terminal. The validity of the leakage switch must be inspected periodically.

10) User must install overload and leakage protection devices at the power terminal. For consideration of safety, each unit must be equipped with independent leakage protection device and the action value  $I_{\Delta n} \leq 30\text{mA}$ .

11) The electric cabinet of unit is with control signal of water pump and auxiliary electric heating (24V DC; capacity: 5A), which can drive the water pump and the AC contactor of auxiliary electric heater. Do not use the control signal of water pump or auxiliary electric heater of electric cabinet to drive the water pump motor and auxiliary electric heater.

12) Notices for the power configuration. Stationary appliances not fitted with means for disconnection from the supply mains having a contact separation in all poles that provide full disconnection under overvoltage category III, the instructions state that means for disconnection must be incorporated in the fixed wiring in accordance with the wiring rules.

Model	Power type	Min sectional area of power cord (mm <sup>2</sup> )			Capacity of air switch (A)
		Live wire	Neutral wire	Earthing wire	
CH-HP20CMFNM	380V-415V 3N~ 50Hz	2.5	2.5	2.5	25
CH-HP30CMFNM	380V-415V 3N~ 50Hz	4	4	4	32
CH-HP40CMFNM	380V-415V 3N~ 50Hz	6	6	6	40

①The circuit breaker and the power cord is selected according to the maximum power of unit (maximum current).

②If the length of power cord is more than 15m, please increase the sectional area of power cord properly to prevent overcurrent.

③Heat pump water heater belongs to type I electric appliances, which must be grounded reliably.

④The yellow-green wire inside the unit is the earthing wire. Do not connect the earthing wire to below places:

- a. tap water pipe
- b. gas pipe
- c. blow-off pipe
- d. unreliable places.

⑤Supply cord:

CH-HP20CMFNM:5X2.5mm<sup>2</sup> (H07RN-F)

CH-HP30CMFNM:5X4.0mm<sup>2</sup> (H07RN-F)

CH-HP40CMFNM:5X6.0mm<sup>2</sup> (H07RN-F)

(5) Safety notices for using water

1) User should prepare two pieces of PPR plastic pipe and connect them to water inlet and water outlet respectively. The length of plastic pipe (L):  $L \geq 70 \times R^2$ , L is the pipe length (unit: cm), R is the inner



semidiameter (unit: cm).

2) User installs water pump, auxiliary electric heater and solenoid valve and other electric-charged parts. Users are suggested to adopt PPR plastic pipe and length of plastic pipe from the electric-charged part to the place where human body can touch the water should satisfy above requirement. If using metal pipe, both ends of metal pipe must be grounded reliably.

3) Set reliable earthing device for heating water tank, thermal storage water tank and water supply pipe network.

Safe connection sketch map:

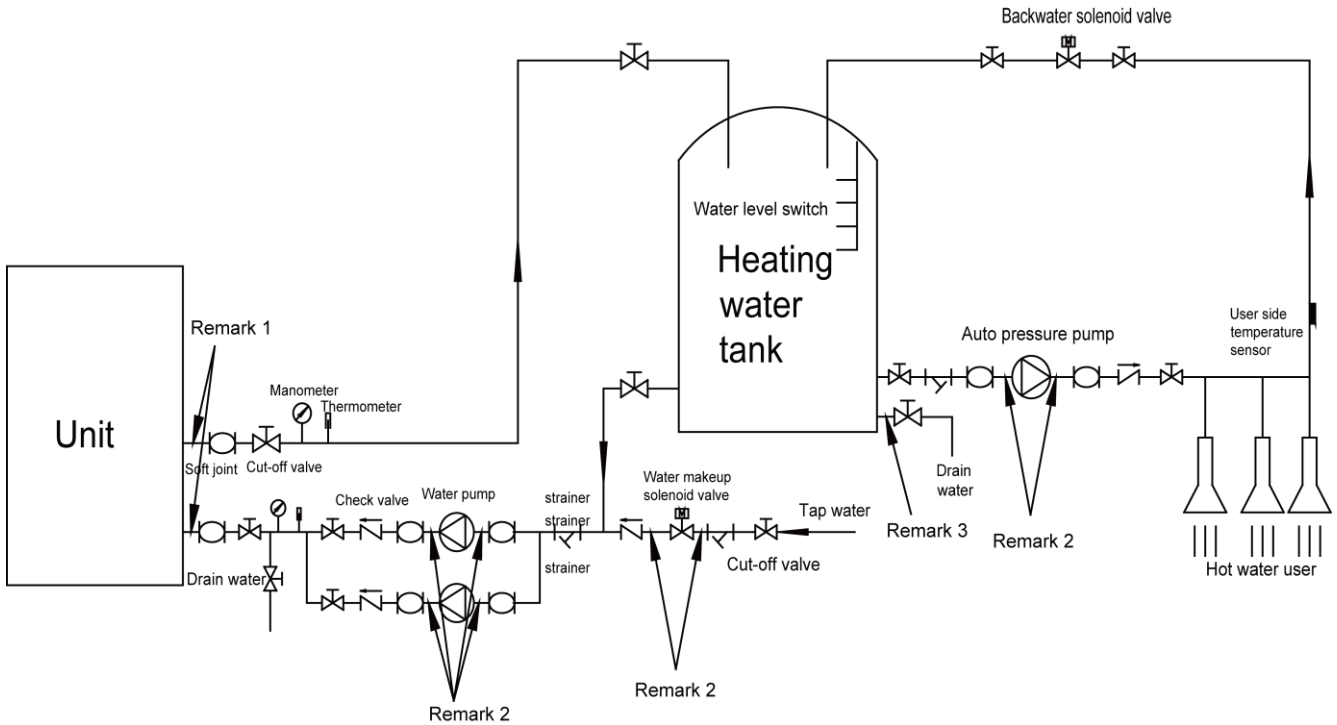

Remark 1: Refer to item 1) in (5) Safety Notices for Using Water

Remark 2: Refer to item 2) in (5) Safety Notices for Using Water

Remark 3: Refer to item 3) in (5) Safety Notices for Using Water

## 5 DIP switch setting on main board

Note:

- 1) This instruction is only applicable for the main board of water heater;
- 2) Please ask professional person to operate the DIP.
- 3) Cut off the power before operating the DIP.

There are two groups DIP for the main board of water heater. The first SA3 (4-bit DIP) group is the address DIP for the unit, which is set 1# unit during ex-factory and can be operated by professional debugging person. The other group SA5 (2-bit) is the parameters DIP, which is set well at ex-factory.

DIP address setting will be stated as below by two kinds of circumstances:

### (1) Single unit

If the system is constituted by one set unit, the professional debugging person only have check and confirm whether the DIP is 1# because the address DIP is set at 1# unit at ex-factory. Therefore, it's no need to operate this DIP.

(2) Module unit

If the modular system is constituted by multiple unit, the address Dip should be operate by the professional debugging person during installation.

In module system, you must appoint one unit as the 1# unit, and connect wires strictly according to the electric wiring diagram of master module in this instruction manual ( wired controller, water level switch, water discharge valve, water makeup valve must be controlled through master module). The other units are 2#、3#...16# in turn.

Because all the units are the same, you can appointed the most convenient unit in the product as the 1# unit and connect wires according to the wiring diagram of master unit in this instruction manual.

Address DIP of unit: (black part is the deflector rod)

DIP	Position				Address	Instruction
	1	2	3	4		
SA3	ON	ON	ON	ON	1#	ON: pull the deflector rod to the direction of ON; the opposite direction is OFF.
	OFF	ON	ON	ON	2#	
	ON	OFF	ON	ON	3#	
	OFF	OFF	ON	ON	4#	
	ON	ON	OFF	ON	5#	
	OFF	ON	OFF	ON	6#	
	ON	OFF	OFF	ON	7#	
	OFF	OFF	OFF	ON	8#	
	ON	ON	ON	OFF	9#	
	OFF	ON	ON	OFF	10#	
	ON	OFF	ON	OFF	11#	
	OFF	OFF	ON	OFF	12#	
	ON	ON	OFF	OFF	13#	
	OFF	ON	OFF	OFF	14#	
	ON	OFF	OFF	OFF	15#	
	OFF	OFF	OFF	OFF	16#	

Address DIP diagram: (black part is the deflector rod)

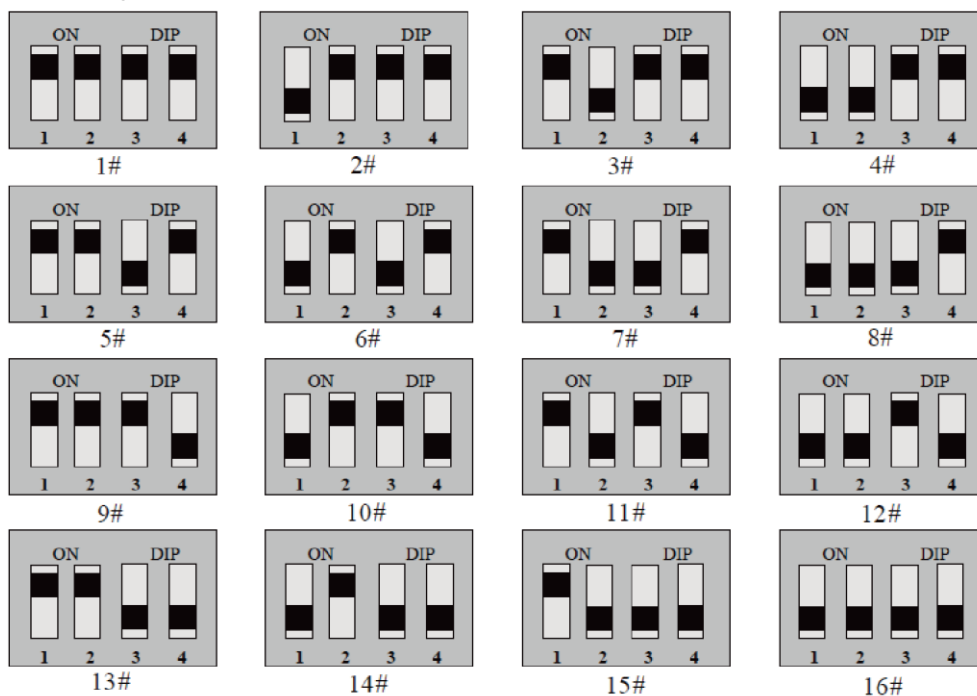

## 6 Debugging, daily operation and maintenance

### 6.1 Before debugging

#### (1) Check the unit

1) Check whether the appearance of the unit or the pipeline system is damaged during the transportation.

2) Check whether the wiring terminals of the electric parts inside the unit are loose.

3) Check whether blades of the unit are interfering with outer case and grille.

4) Check whether all temperature sensor is inserted tightly.

5) Check whether the electronic expansion valve is installed tightly.

#### (2) Check the pipeline system

1) Check whether all valves needed to be opened are opened and whether all valves needed to be closed are closed.

2) Check whether water tank is full of water and whether the water-level switch is installed correctly.

3) Check whether the thermal insulation for the water pipeline system is in good condition.

#### (3) Check the electrical system.

1) Check whether the power supply is consistent with the power required on instruction manual and nameplate on the unit.

2) Check whether the specification of the power cord is consistent with that required on the instruction manual.

3) Check whether the wire connection for the power cord is correct.

4) Check whether the power supply and the control wiring are connected correctly and tightly, whether the grounding is reliable and whether all wiring terminals are fixed tightly.

### 6.2 Test run



**Note:** Test run must be conducted when all above checkup items are qualified and guided by professional persons.

(1) Energize the unit and then turn on the unit. As for the unit adopting three-phase power, if the power cord is connected reversely, the phase protector will be activated. The main board inside the electric box is not energized. Therefore, the fan, the compressor and the water pump won't operate. Please cut off the power at first, re-connect the three-phase power cord and then energize and turn on the unit.

(2) During operation, the circulating water pump should operate placidly. If the water pump can't operate placidly and the swing fluctuation for the needle pointer of manometer is large, it indicates there's still air inside the water system. Please discharge all air and then turn on the unit.

(3) If there's abnormal sound when the compressor is started up, please stop operation immediately and check it. When there's no abnormal sound any more, please resume the operation.

(4) Observe whether the inlet water temperature and the outlet water temperature for the unit are normal. If the temperature difference between outlet water temperature and inlet water temperature  $\Delta T > 5^{\circ}\text{C}$ , it indicates the water flow volume inside the system is small. Please check whether the water

strainer is blocked, whether the air discharged and whether the resistance for the pipeline system is too big.  $\Delta T$  should be 3~5°C.

(5) After test run is finished, clean the strainer on the pipeline before normal operation. After a period of time (eg: three months), remove and clean the strainer periodically (eg: every month) for ensuring normal operation of the unit.

(6) During test run period, if the interval of stop operation for compressor is less than 3mins, do not turn on the unit with hand. If the operation is no more than 6mins, do not stop operation with hand.

 Note: Because the unit adopts totally-enclosed scroll compressor, the phase sequence of power must be correct.

## 6.3 Daily operation and maintenance

(1) At the time of ex-factory time, all the safety protection switches have been sent. Users can't adjust or eliminated it by themselves.

(2) For the first operation of the unit or restart up the unit when the unit has been cut off power for a long time (24h above), connect the supply power of the unit in advance to preheat the unit for 8hours above for avoiding damage to the compressor.

(3) Do not pile up sundries on the unit and accessories. The surroundings of the unit should be kept dry, clean and well-ventilated. If there's too much dust on the fins of the condenser, please eliminate them in time to prevent affecting performance of unit.

(4) Clean the strainer inside the water system periodically to prevent protection or damage to the unit due to blockage of the water system. Meanwhile, frequently check whether the water supplement device inside the water system is normal.

(5) If the ambient temperature in winter is below 0°C, prohibit cutting off the power. When the unit won't be used for a long time, you should not only discharge the water inside the water system, but also remove the choke plug of water tank to discharge the water inside the water tank for preventing damage to the parts inside the unit.

(6) Do not turn on or turn off the unit frequently. Do not close the regulator valve of water system with hand freely during operation.

(7) Please check the working status of all parts of the unit. Check whether there's grease on the pipeline joints inside the unit and refrigerant-charging valve to make sure there's refrigerant leakage. If there's leakage, please contact local appointed maintenance center for maintenance.

(8) If there's malfunction for the unit and the user can't solve it, please contact local appointed maintenance center in time.

## 7 Troubleshooting

 Caution: If there's malfunction during operation process, please contact local dealer or appointed maintenance center.

(1) Below phenomenons are not belong to malfunction:

1) During operation in winter, the surface temperature of the heat exchanger is lower than outdoor ambient temperature, and when the surface temperature is lower than 0°C, there will be frost on the surface of heat exchanger, which will affect the heat-exchanging efficiency. Therefore, the control system

will defrost periodically.

2) As for operating the unit at those regions whose temperature is lower than 0°C in winter: when the system is at standby status, and ambient temperature and water temperature of system is at 0°C, in order to prevent water system icing up and damaging equipments, the control system will operate at freeze prevention condition. Start up water pump and compressor until the water temperature reaches to safety point.

3) If the ambient temperature during operation is high, the fan may operate at low fan speed.

4) If start up the unit or turning on the manual switch immediately after stopping operation, the unit won't operate within 3min, which is the delay protection for the compressor.

5) During defrosting operation, the fan motor of the unit stops operation.

6) Under normal working condition of generating hot water, the 4-way valve is at de-energization status.

7) The water outlet temperature under low temperature can't reach the set temperature. Under the low ambient temperature, for protecting the unit, the water outlet temperature may can't reach high set temperature, which is the normal phenomenon.

(2) Professional technicians can refer to below troubleshooting table for resolving malfunctions:

Common malfunction	Causes	Troubleshooting
Compressor can't be started up	①There's problem for the power. ②Wire connection is loose ③Malfunction of relay or fuse ④Set temperature is high ⑤Malfunction of compressor	①Check the phase sequence . ②Check it and connect it tightly. ③Check the malfunction causes and resolve it. ④Set it again ⑤Replace compressor.
Big noise for fan	①The fixing bolt for the fan is loose. ②Blades touch outer case or grille. ③The fan can't operate placidly.	①Tighten the fixing bolts of fan. ②Check it and adjust it. ③Replace the fan.
Big noise for the compressor	① There's liquid slugging when liquid refrigerant entering into compressor. ②There's damaged parts inside the compressor.	① Check whether the expansion valve is valid and whether the temperature is loose. ②Replace compressor.
Water pump can't operate or the operation is abnormal	①Power malfunction of wiring malfunction. ②Malfunction of relay ② There's air inside the water pipe .	①Find out the reason and repair it. ②Replace relay . ③Discharge the air completely.
Compressor is turned on or turned off frequently	① Refrigerant is superfluous or too less. ②Poor circulation for the water system. ③Low load.	①Add or release some refrigerant. ②The water system is blocked or there's air inside the water system. Please check water pump, valve and pipeline, clean the strainer or discharge air. ③Adjust the load or add energy-storage device.
Compressor operates, while the unit can't heat	①All refrigerant are leaked. ②Malfunction of compressor.	①Repair it and complement refrigerant. ②Replace compressor.
The hot water generation effect is not obvious.	①The thermal insulation for the water system is poor. ②The heat-exchanging effect for the evaporator is poor. ② Refrigerant is insufficient.	①Enforce the thermal insulation for the system. ②Check whether air inlet and air outlet for the unit is normal and clean the evaporator. ③Check whether there's refrigerant leakage for the unit, and add some refrigerant.

(3) Drain water in winter:

 Caution: In order to drain the residual water in evaporator and condenser, the water drain valve of water system should be kept at on status!

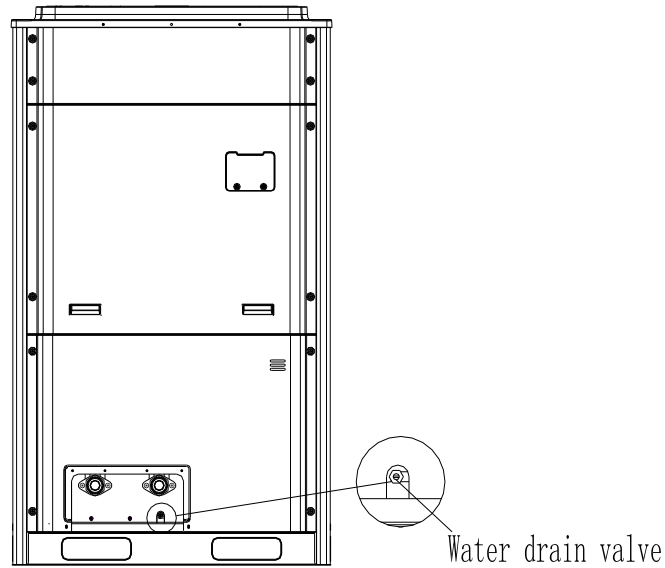

## 8 Error code

Error code for the controller of water heater			
Error code	Malfunction causes	Unit status	Reset method
F3	Malfunction of outdoor ambient temperature sensor	OFF	Auto
F4	Malfunction of discharge temperature sensor	OFF	Auto
F5	Malfunction for outdoor inlet tube temperature sensor	OFF	Auto
F7	Malfunction of outdoor outlet tube temperature sensor	OFF	Auto
F8	Malfunction of water inlet temperature sensor	Floor heating mode: OFF Hot water mode: /	Auto
F9	Malfunction of water outlet temperature sensor	Floor heating mode: OFF Hot water mode: /	Auto
E1	High pressure protection	OFF	Auto
E3	Low pressure protection	OFF	Auto
E4	Discharge high temperature sensor protection	OFF	Auto
E5	Overload protection for compressor	OFF	Auto
E6	Communication malfunction	OFF	Auto
E0	Overload protection of water pump	OFF	Auto
EF	Overload protection of outdoor fan	OFF	Auto
Ec	Water flow switch protection	OFF	Auto
L2	Malfunction of water flow switch of water tank	OFF	Auto
d2	Auto freeze prevention protection in winter	ON	Auto
Ed	Overheating protection for water outlet	OFF	Auto
L5	Malfunction of water tank temperature sensor	OFF	Auto
n6	Communication malfunction for drive board of spray electronic expansion valve	OFF	Auto



1) Auto reset: The unit resumes operation automatically when malfunction is eliminated and the protection time for stopping operation of compressor is satisfied.

2) Manual reset: Press the reset button directly and the unit will resume operation when it detected that the malfunction for the unit is eliminated.

3) If low pressure protection is detected for the two times within 40mins, the reset method should be switched to manual from auto type.

4) If low overload protection for compressor or fan motor is detected for the three times within 30mins, the reset method should be switched to manual from auto type.

If there's quality problem or the unit can't operate normally within the warranty period, please contact local maintenance center for free repair.

User must appoint person to manage and operate this unit correctly and reasonable according to this instruction manual. Otherwise, improper operation may cause accidents. Users should bear the responsibility by themselves.



66129920274