



Service Manual

**MODELS: CH-S18FTXG, CH-S24FTXG
GENERATION III
(Refrigerant R-410A)**

CONTENTS

Summary and Features

1. Safety Precautions	1
2. Specifications	2
2.1 Unit Specifications	2
2.2 Operation Characteristic Curve	16
2.3 Capacity Variation Ratio According to Temperature	16
2.4 Operation Data	17
2.5 Noise Criteria Curve Tables for Both Models.....	18
3. Construction Views	19
3.1 Indoor Unit.....	19
3.2 Outdoor Unit	19
4. Refrigerant System Diagram	20
4.1 18K	20
4.2 24K	21
5. Schematic Diagram	22
5.1 Electrical Data	22
5.2 Electrical Wiring.....	22
5.3 Printed Circuit Board	25
6. Function and Control	30
6.1 Remote Controller Description	30
6.2 Changing Batteries and Notices	33
6.3 Unit Indication Section.....	33
6.4 Unit ON/OFF Button	33
6.5 Description of Each Control Operation.....	34

7. Installation Manual	39
7.1 Tools Required for Installation	39
7.2 Installation Position Selection.....	39
7.3 Installation of Indoor Unit.....	40
7.4 Installation of Outdoor Unit.....	43
7.5 Power	45
7.6 Test Operation	45
8. Exploded Views and Parts List	46
8.1 Indoor Unit.....	46
8.2 Outdoor Unit	60
9. Troubleshooting	68
9.1 Precautions before Performing Inspection or Repair.....	68
9.2 Confirmation	69
9.3 Flashing LED of Indoor/Outdoor Unit and Primary Judgement	69
9.4 How to Check simply the main part.....	74
9.5 2-way, 3-way Valve Appearance.....	92
10. Removal Procedure	99
10.1 Removal Procedure of Indoor Unit	99
10.2 Removal Procedure of Outdoor Unit	105

Summary and features

Indoor/Outdoor Unit

CH-S18FTXG

CH-S24FTXG



Remote control window

YB1F2



1. Safety Precautions

Important!

Please Read Before Starting

Installing, starting up, and servicing air conditioner can be hazardous due to system pressure, electrical components, and equipment location, etc.

Only trained, qualified installers and service personnel are allowed to install, start-up, and service this equipment.

Untrained personnel can perform basic maintenance functions such as cleaning coils. All other operations should be performed by trained service personnel.

When handling the equipment, observe precautions in the manual and on tags, stickers, and labels attached to the equipment. Follow all safety codes. Wear safety glasses and work gloves. Keep quenching cloth and fire extinguisher nearby when brazing.

Read the instructions thoroughly and follow all warnings or cautions in literature and attached to the unit. Consult local building codes and current editions of national as well as local electrical codes.

Recognize the following safety information:

 **Warning** Incorrect handling could result in personal injury or death.

 **Caution** Incorrect handling may result in minor injury, or damage to product or property.

- Make sure the outdoor unit is installed on a stable, level surface with no accumulation of snow, leaves, or trash beside.
- Make sure the ceiling/wall is strong enough to bear the weight of the unit.
- Make sure the noise of the outdoor unit does not disturb neighbors.
- Follow all the installation instructions to minimize the risk of damage from earthquakes, typhoons or strong winds.
- Avoid contact between refrigerant and fire as it generates poisonous gas.
- Apply specified refrigerant only. Never have it mixed with any other refrigerant. Never have air remain in the refrigerant line as it may lead to rupture and other hazards.
- Make sure no refrigerant gas is leaking out when installation is completed.
- Should there be refrigerant leakage, the density of refrigerant in the air shall in no way exceed its limited value, or it may lead to explosion.
- Keep your fingers and clothing away from any moving parts.
- Clear the site after installation. Make sure no foreign objects are left in the unit.
- Always ensure effective grounding for the unit.

Warning

All electric work must be performed by a licensed technician according to local regulations and the instructions given in this manual.

- Before installing, modifying, or servicing system, main electrical disconnect switch must be in the OFF position. There may be more than 1 disconnect switch. Lock out and tag switch with a suitable warning label.
- Never supply power to the unit unless all wiring and tubing are completed, reconnected and checked.
- This system adopts highly dangerous electrical voltage. Incorrect connection or inadequate grounding can cause personal injury or death. Stick to the wiring diagram and all the instructions when wiring.
- Have the unit adequately grounded in accordance with local electrical codes.
- Have all wiring connected tightly. Loose connection may lead to overheating and a possible fire hazard.

All installation or repair work shall be performed by your dealer or a specialized subcontractor as there is the risk of fire, electric shock, explosion or injury.

Caution

- Never install the unit in a place where a combustible gas might leak, or it may lead to fire or explosion.
- Make a proper provision against noise when the unit is installed at a telecommunication center or hospital.
- Provide an electric leak breaker when it is installed in a watery place.
- Never wash the unit with water.
- Handle unit transportation with care. The unit should not be carried by only one person if it is more than 20kg.
- Never touch the heat exchanger fins with bare hands.
- Never touch the compressor or refrigerant piping without wearing glove.
- Do not have the unit operate without air filter.
- Should any emergency occur, stop the unit and disconnect the power immediately.
- Properly insulate any tubing running inside the room to prevent the water from damaging the wall.

2. Specifications

2.1 Unit Specifications

18K

Model (Product Code)			CH-S18FTXG	CH-S24FTXG	
Power Supply	Rated Voltage	V~	220-240	220-240	
	Rated Frequency	Hz	50	50	
	Phases		1	1	
Power Supply Mode			Indoor	Indoor	
Cooling Capacity (Min~Max)		W	5300(1050~6500)	6450(1500~7000)	
Heating Capacity (Min~Max)		W	5700(1000~7000)	7000(1200~7800)	
Cooling Power Input (Min~Max)		W	1310(360~2500)	1850(350~2500)	
Heating Power Input (Min~Max)		W	1350(350~2600)	1980(350~2700)	
Cooling Power Current		A	7.12	8.8	
Heating Power Current		A	7.03	8.56	
Rated Input		W	2600	2700	
Rated Current		A	11.6	11.98	
Air Flow Volume(SH/H/M/L/SL)		m ³ /h	800/680/560/460/-	950/800/650/550/-	
Dehumidifying Volume		L/h	1.8	2	
EER		W/W	4.00	3.78	
COP		W/W	4.20	3.90	
SEER		W/W	-	-	
HSPF		W/W	-	-	
Application Area		m ²	23-34	27-42	
Indoor Unit	Model of indoor unit		CH-S18FTXG	CH-S24FTXG	
	Fan Type		Cross-flow	Cross-flow	
	Diameter Length(DXL)		mm	Φ98X650	Φ98X765
	Fan Motor Cooling Speed (SH/H/M/L/SL)		r/min	1300/1100/950/800/-	1250/1100/950/800/-
	Fan Motor Heating Speed (SH/H/M/L/SL)		r/min	1400/1200/1050/900/-	1300/1100/1000/850/-
	Output of Fan Motor		W	20	35
	Fan Motor RLA		A	0.31	0.31
	Fan Motor Capacitor		μF	1.5	2.5
	Input of Heater		W	-	-
	Evaporator Form			Aluminum Fin-copper Tube	Aluminum Fin-copper Tube
	Pipe Diameter		mm	Φ7	Φ7
	Row-fin Gap		mm	2-1.4	2-1.5
	Coil Length (LXD _X W)		mm	657X25.4X304.8	765X25.4X342.9
	Swing Motor Model			MP28VB	MP35XX
	Output of Swing Motor		W	2	2.5
	Fuse		A	3.15	3.15
	Sound Pressure Level (SH/H/M/L/SL)		dB (A)	45/40/37/32/-	46/42/37/32/-
	Sound Power Level (SH/H/M/L/SL)		dB (A)	55/50/47/42/-	56/52/47/42/-
	Dimension (WXHXD)		mm	865X305X215	1008X319X221
	Dimension of Carton Box (L/W/H)		mm	945X380X295	1073X395X313
Dimension of Package (L/W/H)		mm	948X383X310	1076X398X328	
Net Weight		kg	12	15	
Gross Weight		kg	16	20	

	Model of Outdoor Unit		CH-S18FTXG	CH-S24FTXG
	Compressor Manufacturer/Trademark		China Resources (Shenyang) Sanyo CO.,LTD/Sanyo or Daikin	China Resources (Shenyang) Sanyo CO.,LTD/Sanyo or Daikin
	Compressor Model		C-6RZ146H1A	C-6RZ146H1A
	Compressor Oil		FV50S	FV50S
	Compressor Type		Rotary	Rotary
	L.R.A.	A	41	41
	Compressor RLA		8.4	8.4
	Compressor Power Input		1640	1640
	Overload Protector		1NT11L-3979	1NT11L-3979
	Throttling Method		Capillary	Electron eXpansion valve
	Operation temp	°C	16~30	16~30
	Ambient temp (cooling)	°C	10~48	10~48
	Ambient temp (heating)	°C	-15~24	-15~24
	Condenser Form		Aluminum Fin-copper Tube	Aluminum Fin-copper Tube
	Pipe Diameter	mm	Φ7	Φ9.52
	Rows-fin Gap	mm	2-1.4	2-1.4
	Coil Length (LXD _X W)	mm	853X38.1X660	847X44X660
	Fan Motor Speed	rpm	690	690
	Output of Fan Motor	W	60	60
	Fan Motor RLA	A	0.58	0.58
	Fan Motor Capacitor	μF	3.5	3.5
	Air Flow Volume of Outdoor Unit	m ³ /h	3200	3200
	Fan Type		Axial-flow	Axial-flow
	Fan Diameter	mm	Φ520	Φ520
	Defrosting Method		Auto defrost	Auto defrost
	Climate Type		T1	T1
	Isolation		I	I
	Moisture Protection		IP24	IP24
	Permissible Excessive Operating Pressure for the Discharge Side	MPa	3.0	3.8
	Permissible Excessive Operating Pressure for the Suction Side	MPa	0.9	1.2
	Sound Pressure Level (H/M/L)	dB (A)	54/-/-	56/-/-
	Sound Power Level (H/M/L)	dB (A)	64/-/-	66/-/-
	Dimension (WXHXD)	mm	955X700X396	955X700X396
	Dimension of Carton Box (L/W/H)	mm	1026X455X735	1026X455X735
	Dimension of Package (L/W/H)	mm	1029X458X750	1029X458X750
	Net Weight	kg	52	55
	Gross Weight	kg	57	60
	Refrigerant		R410A	R410A
	Refrigerant Charge	kg	1.25	1.70
Connection Pipe	Length	m	5	5
	Gas Additional Charge	g/m	20	20
	Outer Diameter Liquid Pipe	mm	Φ6	Φ6
	Outer Diameter Gas Pipe	mm	Φ12	Φ12
	Max Distance Height	m	10	10
	Max Distance Length	m	25	25

The above data is subject to change without notice. Please refer to the nameplate of the unit.

2.2 Operation Characteristic Curve

18K

<Cooling>

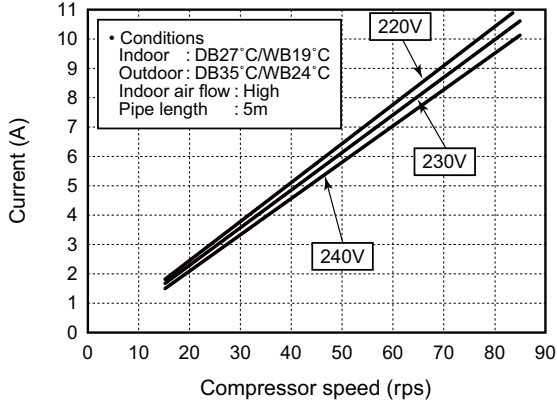

<Heating>

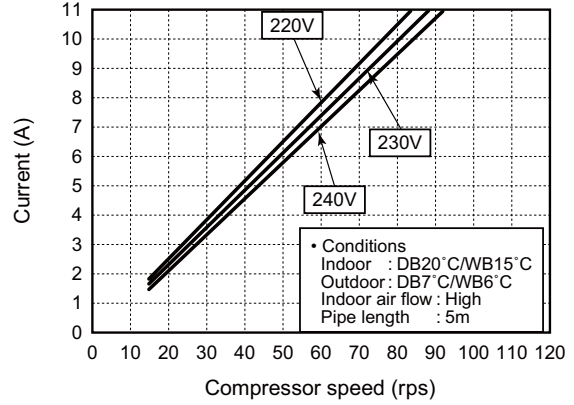

24K

<Cooling>

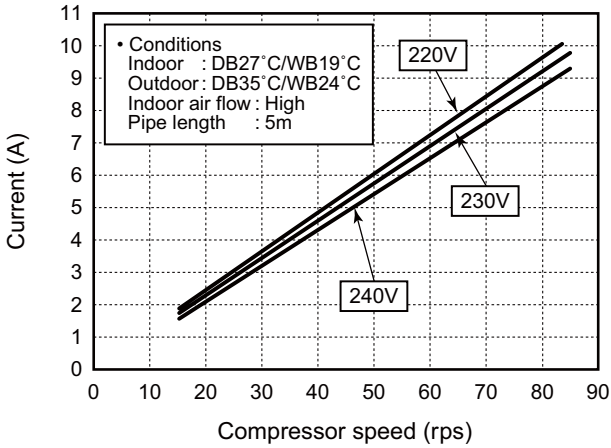

<Heating>

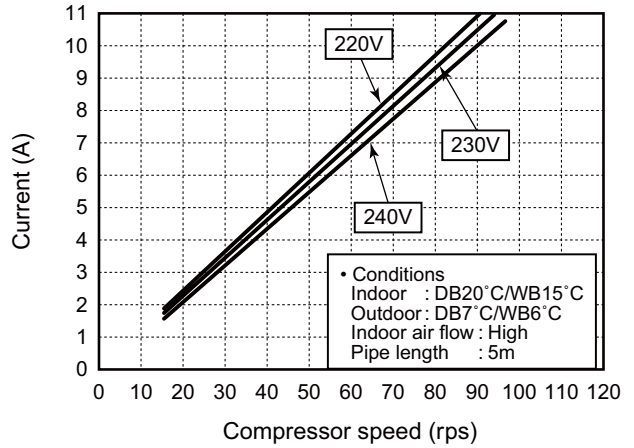

2.3 Capacity Variation Ratio According to Temperature

<Cooling>

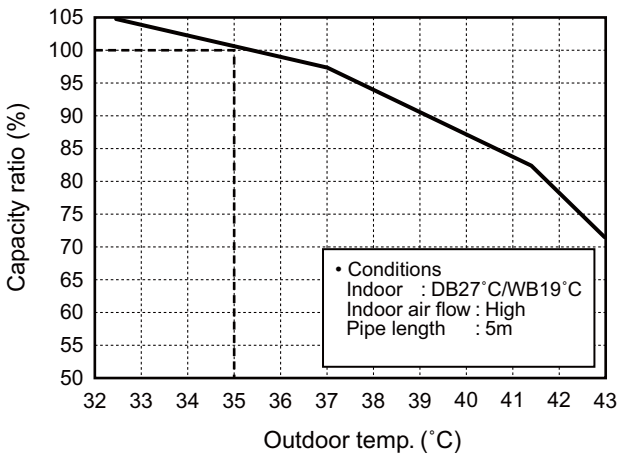

<Heating>

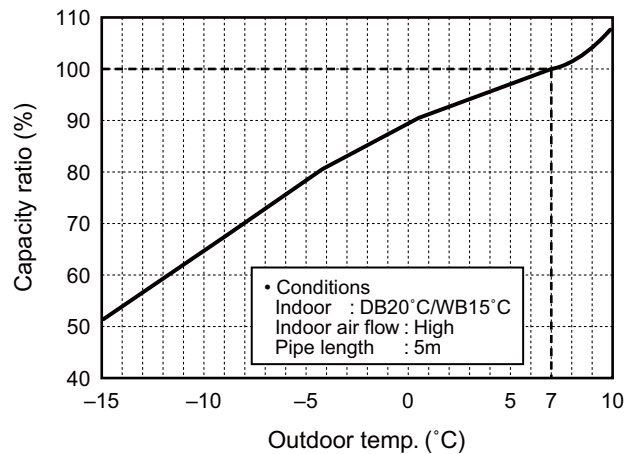

2.4 Operation Data

(1) General energy efficiency unit

Cooling

Temperature condition (°C)		Model name	Standard pressure	Heat exchanger pipe temp.		Indoor fan mode	Outdoor fan mode	Compressor revolution (rps)
Indoor	Outdoor			T1 (°C)	T2 (°C)			
27/19	35/24	18K	0.9 to 1.1	12 to 14	70 to 40	Super High	High	67
		24K	0.8 to 1.0	10 to 12	72 to 40	Super High	High	80

Heating

Temperature condition (°C)		Model name	Standard pressure	Heat exchanger pipe temp.		Indoor fan mode	Outdoor fan mode	Compressor revolution (rps)
Indoor	Outdoor			P (MPa)	T1 (°C)			
20/-	7/6	18K	2.2 to 2.4	70 to 35	2 to 4	Super High	High	60
		24K	2.5 to 2.7	70 to 35	0 to 3	Super High	High	78

(2) High energy efficiency unit

Cooling

Temperature condition (°C)		Model name	Standard pressure	Heat exchanger pipe temp.		Indoor fan mode	Outdoor fan mode	Compressor revolution (rps)
Indoor	Outdoor			T1 (°C)	T2 (°C)			
27/19	35/-	18K	0.9 to 1.1	12 to 14	70 to 40	Super High	High	72
		24K	0.8 to 1.0	10 to 12	72 to 40	Super High	High	83

Heating

Temperature condition (°C)		Model name	Standard pressure	Heat exchanger pipe temp.		Indoor fan mode	Outdoor fan mode	Compressor revolution (rps)
Indoor	Outdoor			P (MPa)	T1 (°C)			
20/-	7/6	18K	2.2 to 2.4	70 to 35	2 to 4	Super High	High	66
		24K	2.5 to 2.7	70 to 35	0 to 3	Super High	High	75

NOTES :

- (1) Measure surface temperature of heat exchanger pipe around center of heat exchanger path U bent. (Thermistor thermometer)
 - (2) Connecting piping condition : 5 m
 - (3) P: pressure of air pipe connected to the indoor and outdoor units (gas valve side)
- T1: Inlet and outlet temperature for evaporator
T2: Inlet and outlet temperature for condenser

2.5 Noise Criteria Curve Tables for Both Models

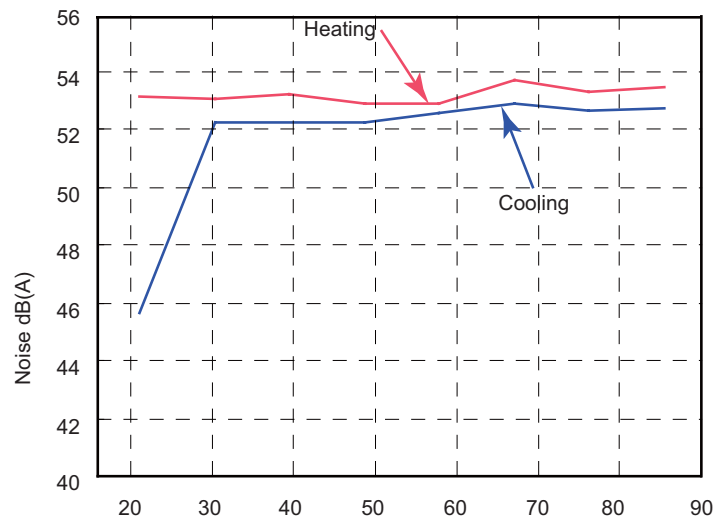
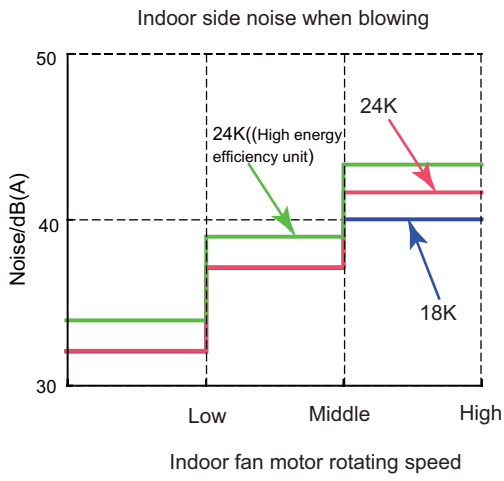

3. Construction Views

3.1 Indoor Unit

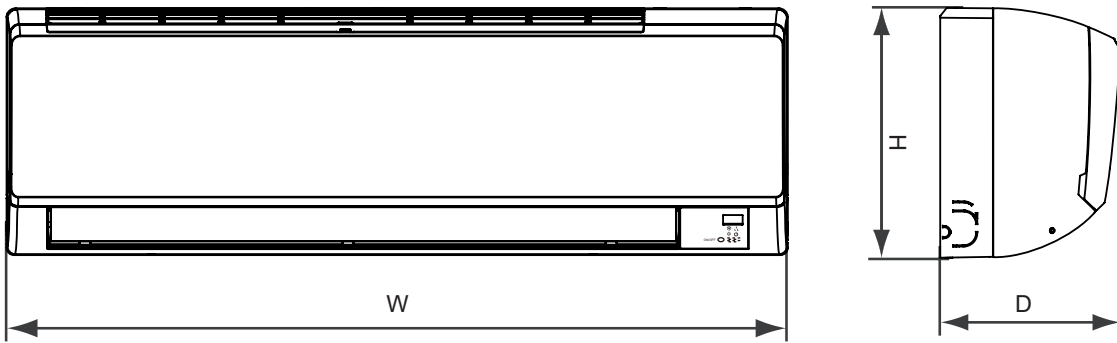

Wall Mounting Frame

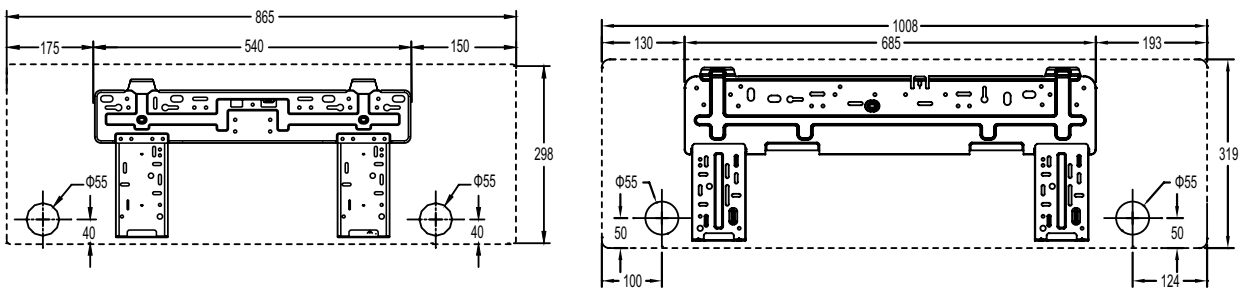

Model	W(mm)	H(mm)	D(mm)
18K	865	305	215/223(GWH18KG-K3DNB1B/I)
24K	1008	319	221

3.2 Outdoor Unit

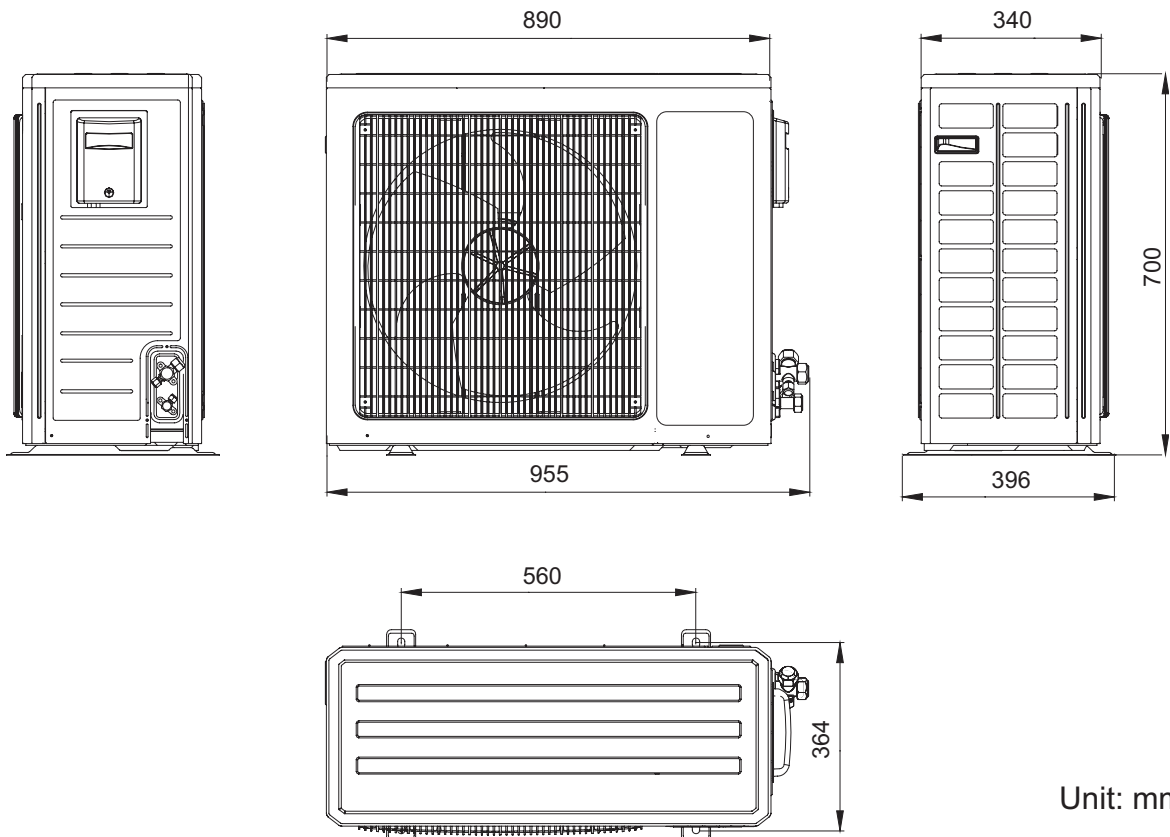

Unit: mm

4. Refrigerant System Diagram

4.1 18K

(1) Cooling Only Models

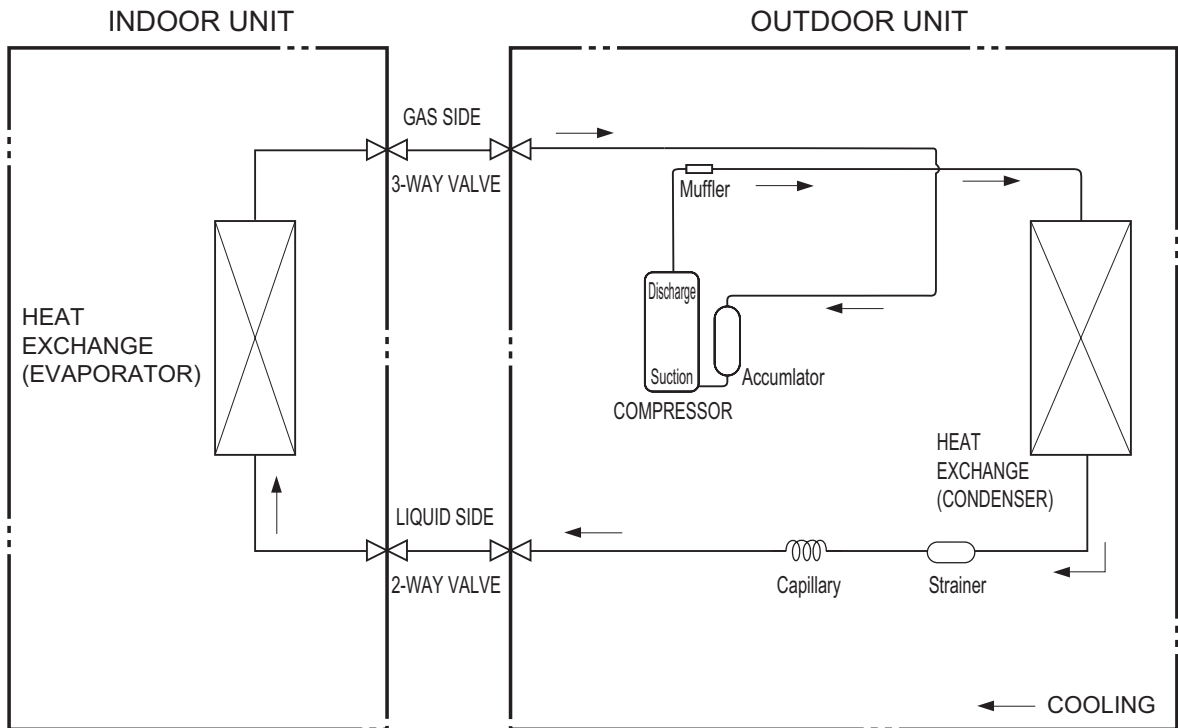

(2) Cooling & Heating Models

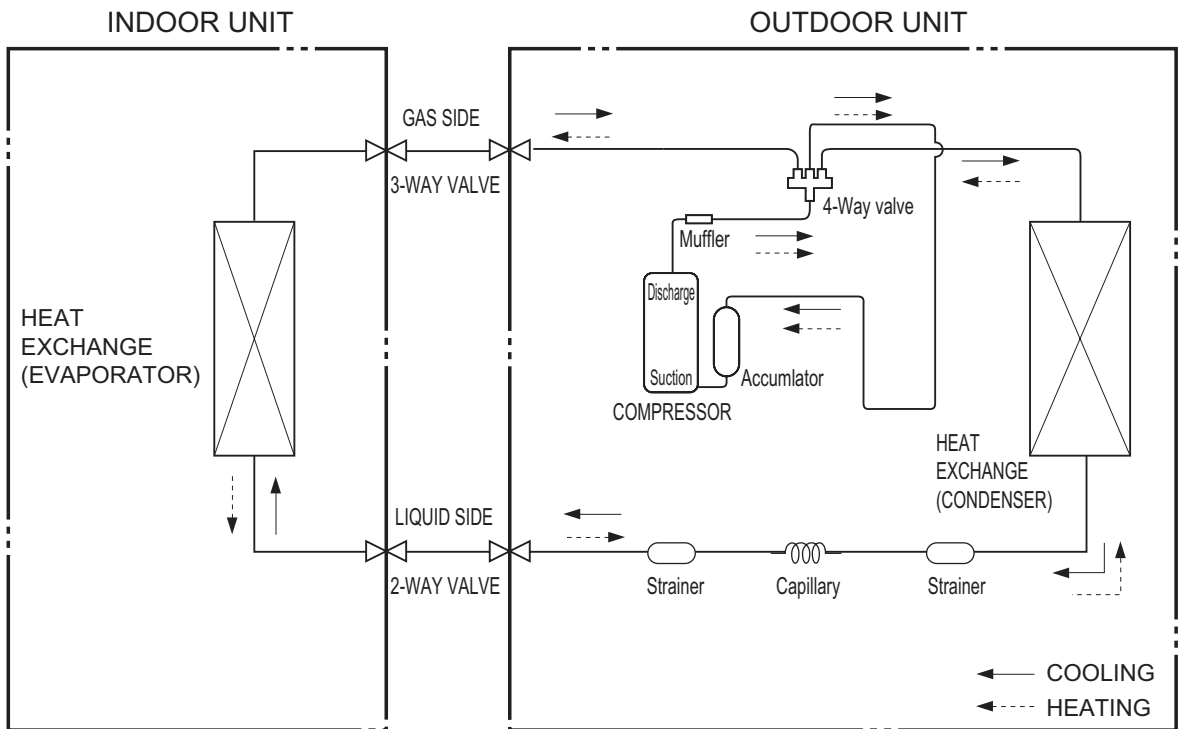

Refrigerant pipe diameter

Liquid : 1/4" (6 mm)

Gas : 1/2" (12 mm)

4.2 24K

(1) Cooling Only Models

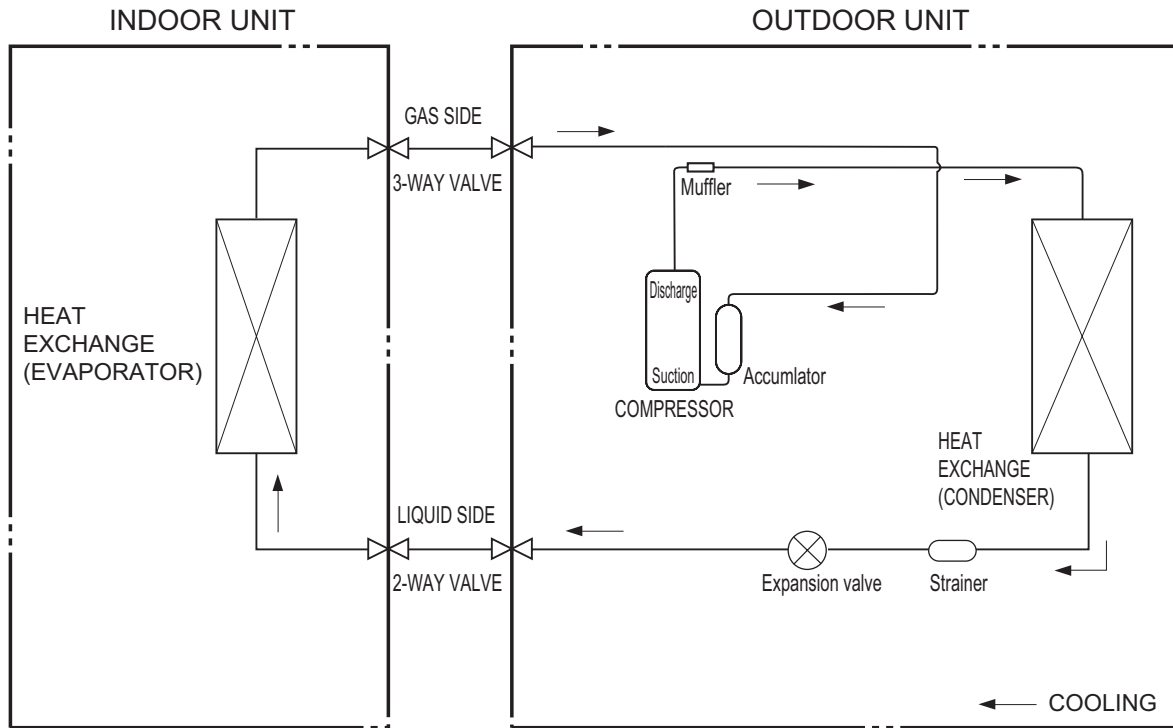

(2) Cooling & Heating Models

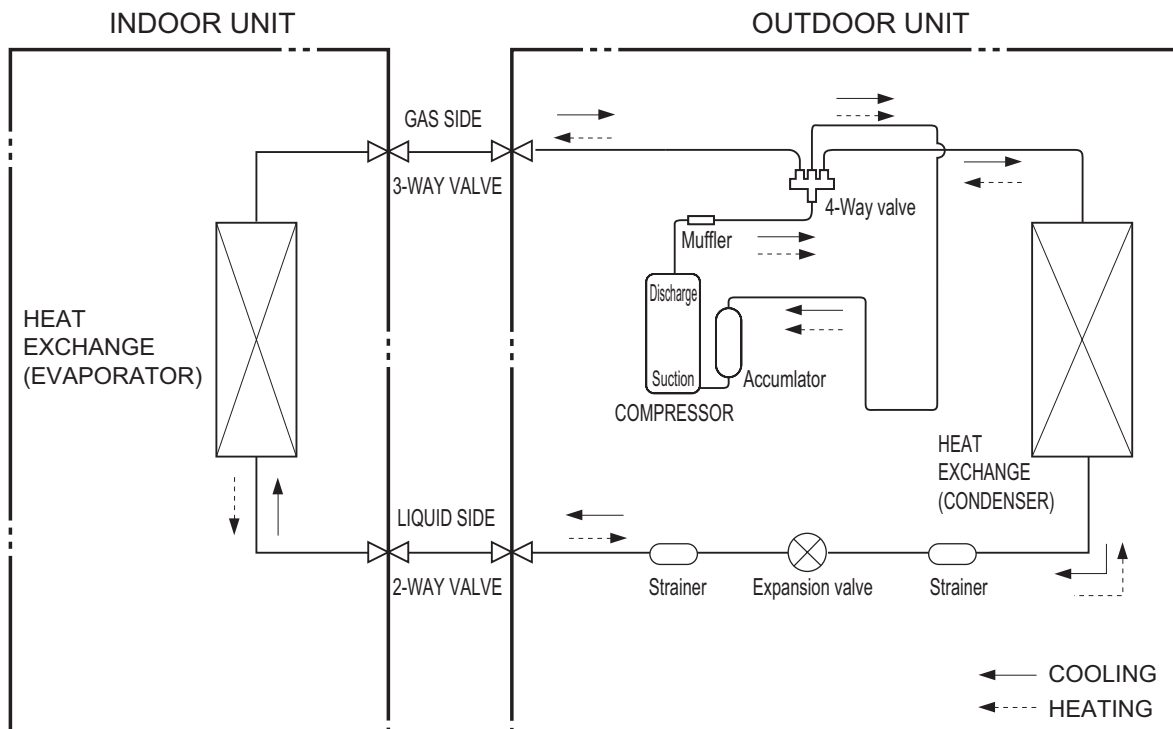

Refrigerant pipe diameter

Liquid : 1/4" (6 mm)

Gas : 1/2" (12 mm)

5. Schematic Diagram

5.1 Electrical Data

Meaning of marks

● Indoor Unit

Symbol	Color symbol	Symbol	Color symbol
BU	BLUE	BN	BROWN
YE	YELLOW	GN	GREEN
RD	RED	BK	BLACK
YEGN	YELLOW GREEN	⊕	PROTECTIVE EARTH

● Outdoor Unit

Symbol	Parts name	Symbol	Color symbol	Symbol	Color symbol
C1	CBB61	BN	BROWN	WH	WHITE
C2	CBB65	BU	BLUE	YE	YELLOW
SAT	OVERLOAD	BK	BLACK	RD	RED
COMP	COMPRESSOR	OG	ORANGE	YEGN	YELLOW GREEN
⊕	PROTECTIVE EARTH	WH	WHITE		

5.2 Electrical Wiring

These circuit diagrams are subject to change without notice, please refer to the one supplied with the unit.

● Indoor Unit

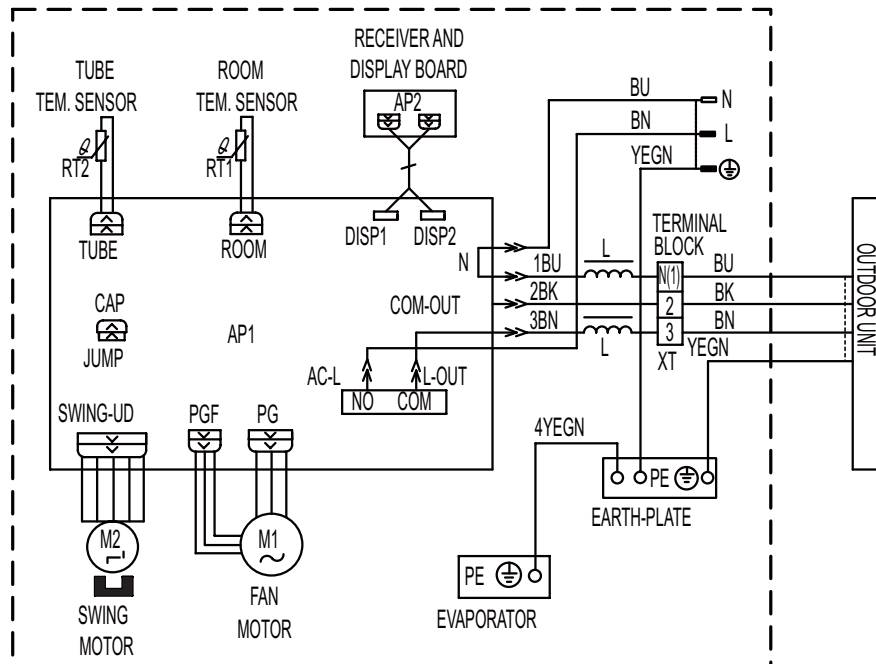

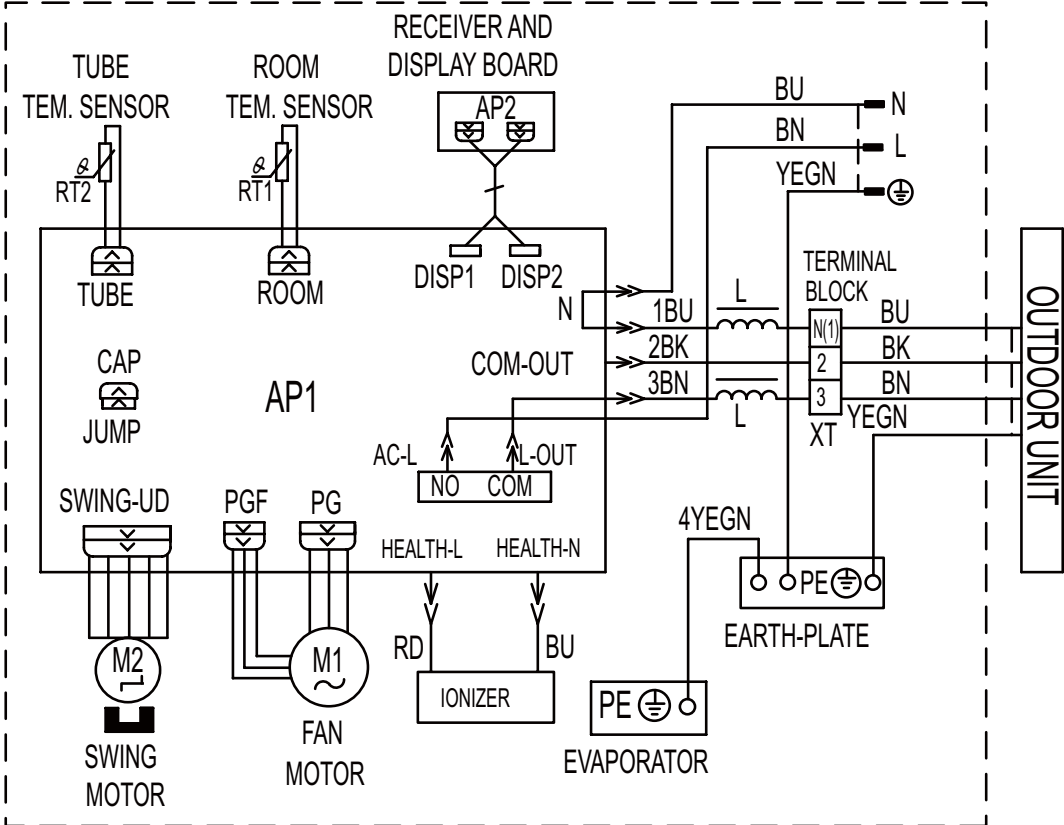

● Outdoor Unit

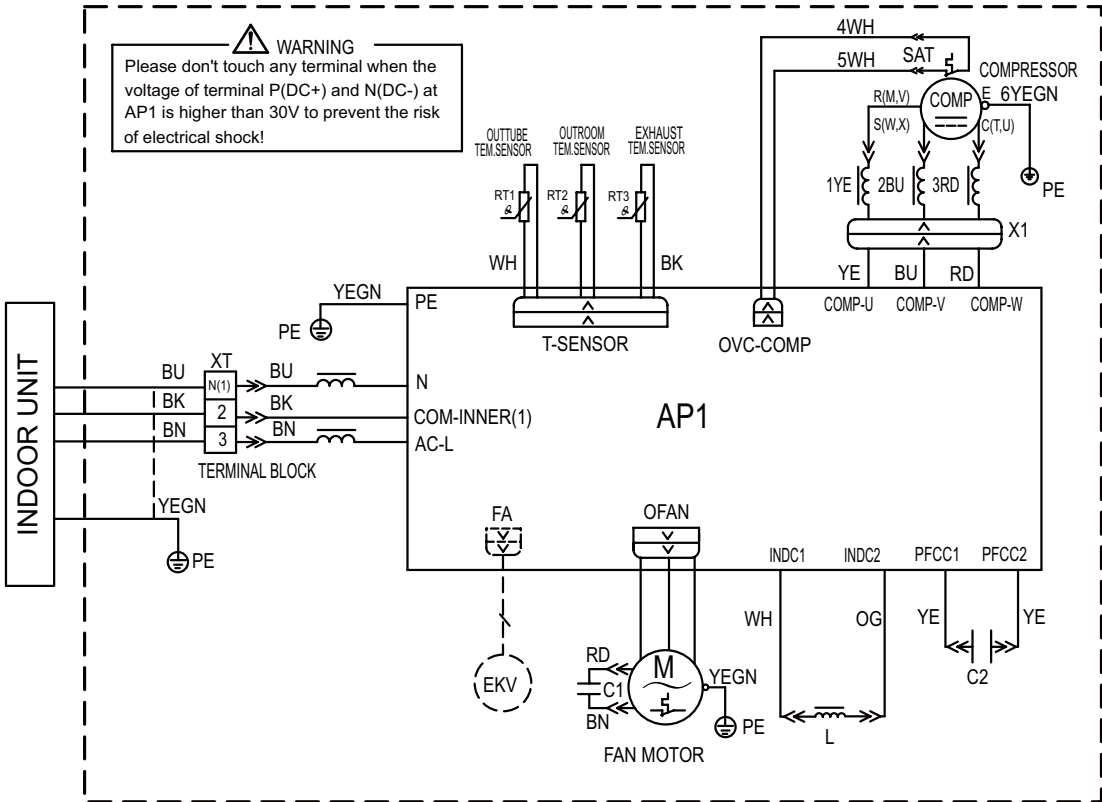

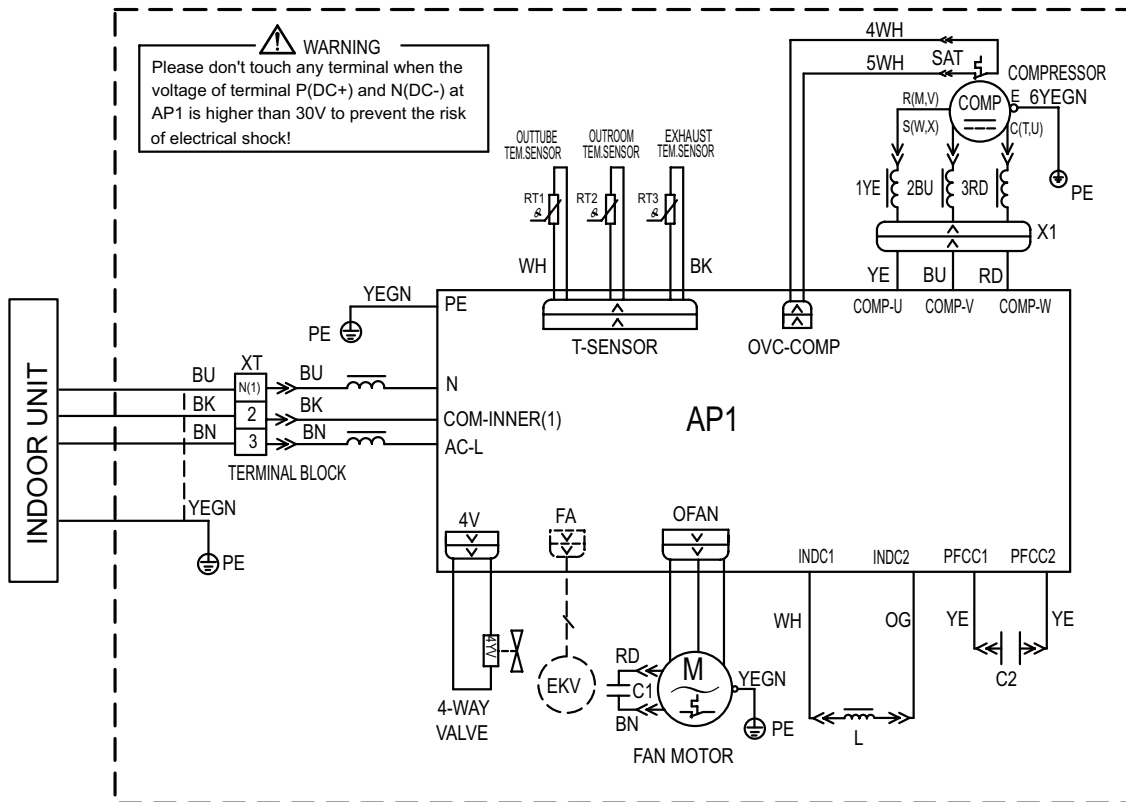

5.3 Printed Circuit Board

Indoor Unit

(1)Control PCB

● TOP VIEW

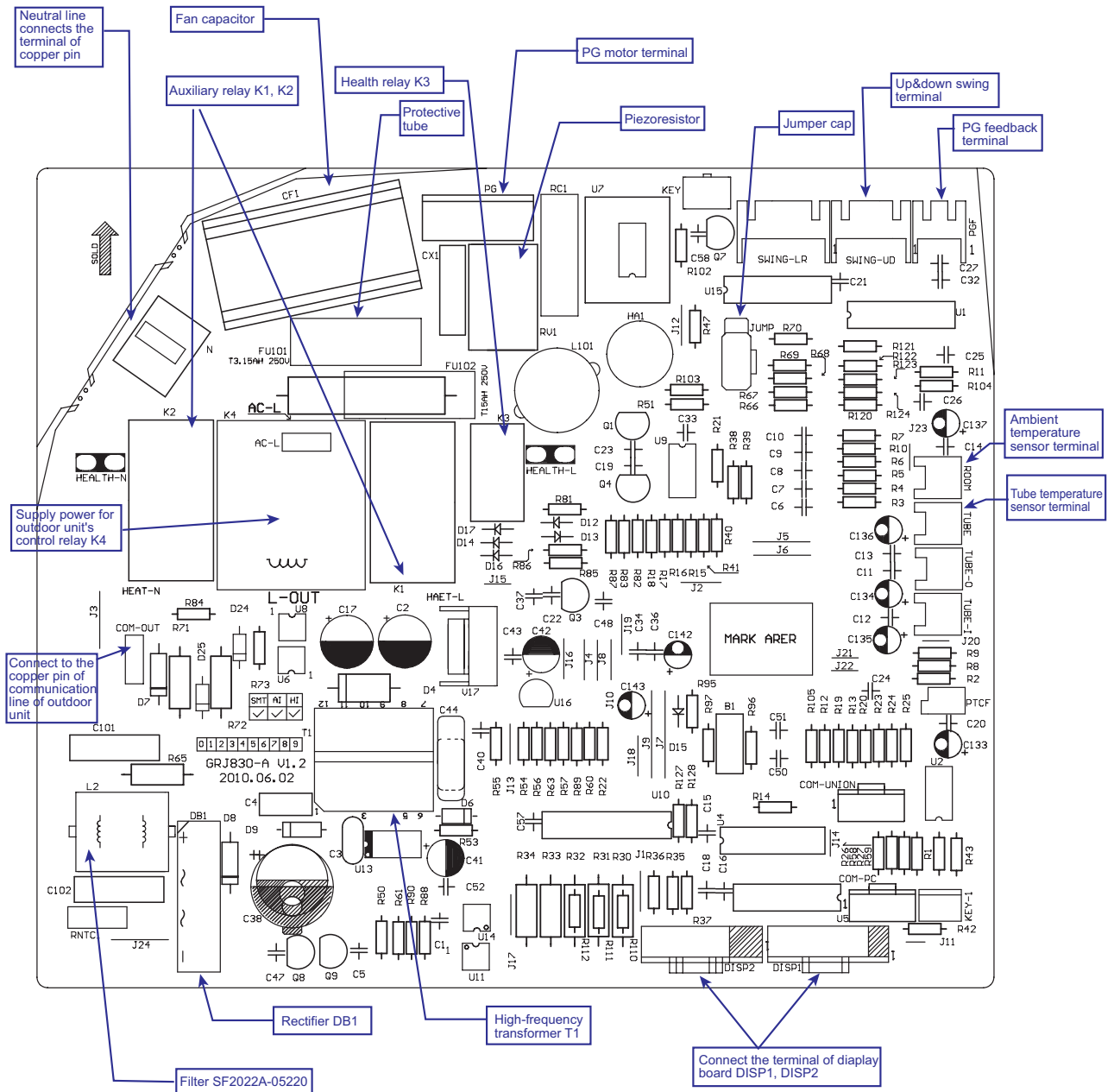

● BOTTOM VIEW

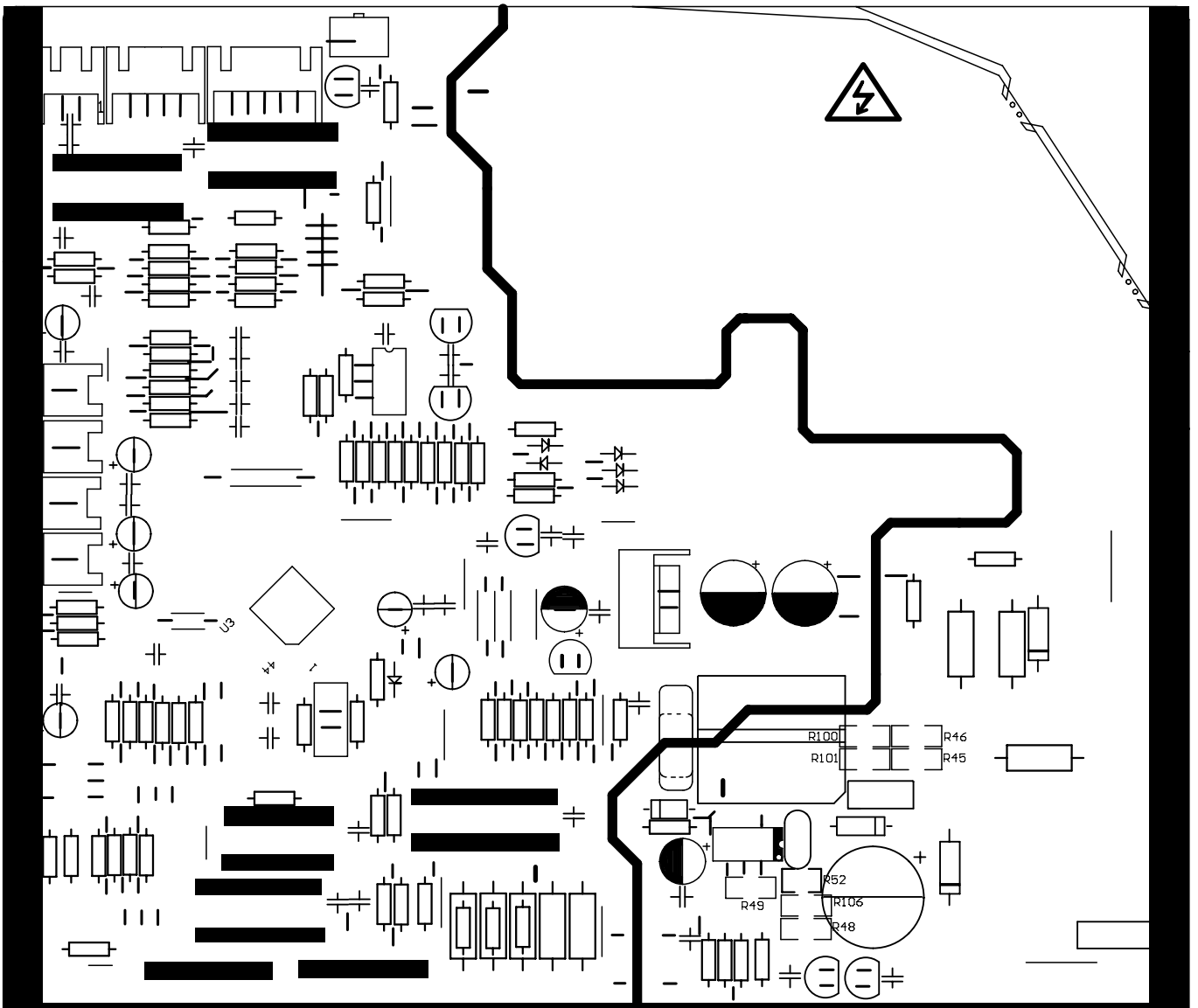

● BOTTOM VIEW

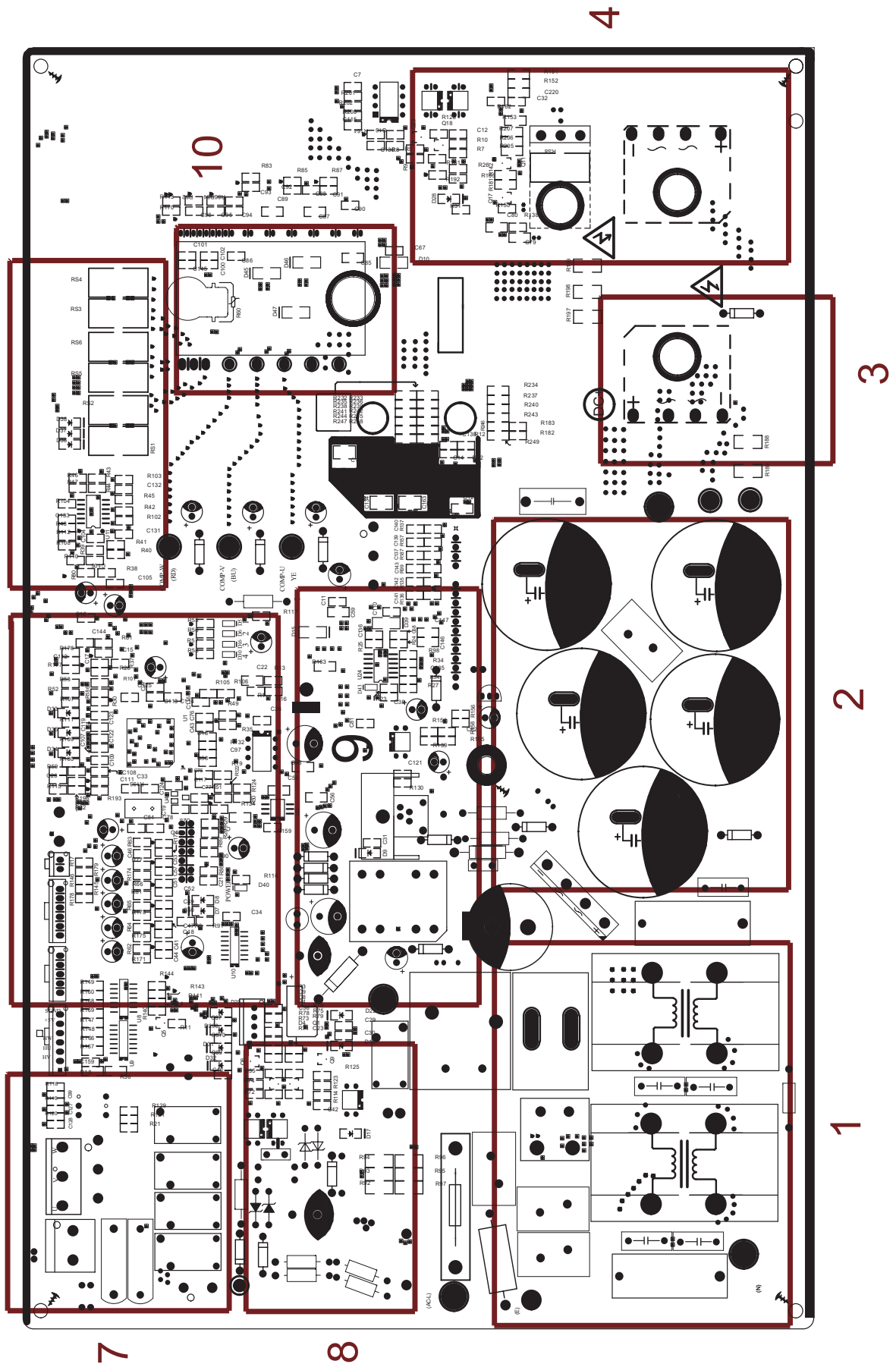

● TOP VIEW

No.	Interface name	Instruction
1	Interface of compressor	The corresponding three wires are: yellow-COMP-U, blue-COMP-V, red-COMP-W
2	Overload protector of compressor	The corresponding two-core white wire connects the overload protector SAT
3	Temperature sensor	Tube temperature (20kΩ@25°C); outdoor ambient temperature(15kΩ@25°C); discharge temperature(50kΩ@25°C)
4	Electron expansion valve	Its used for connecting the 5-core electron expansion valve EKV
5	Fan HALL interface	Its used for connecting DC fans HALL sensor (theres no interface for AC motor)
6	Outdoor fan	Its used for connecting the FAN-MOTOR
7	Four-way valve	Its used for connecting four-way-valve YV
8	Communication interface for indoor unit	Communication wire of indoor and outdoor units, which is connected to the indoor unit
9	Live wire	Power-Source "L"line
10	Earthing wire	Connect to Earth
11	Neutral wire	PowerSource "N"line
12	Interface 1of reactor	Connect to one terminal of Inductor(Whilt)
13	PFC capacitor interface	Connect to C2(Refer to electroical digrame)
14	Interface 2 of reactor	Connect to one terminal of Inductor(Orange)



● BOTTOM VIEW

No.	Circuit module
1	EMI Filter
2	electrolytic capacitors
3	Bridge
4	PFC Circuit
5	Compressor currtent detecting circuit
6	MCU
7	Control circuit of Fan and 4V
8	Communication circuit with Indoor-Unit
9	SMPS
10	IPM



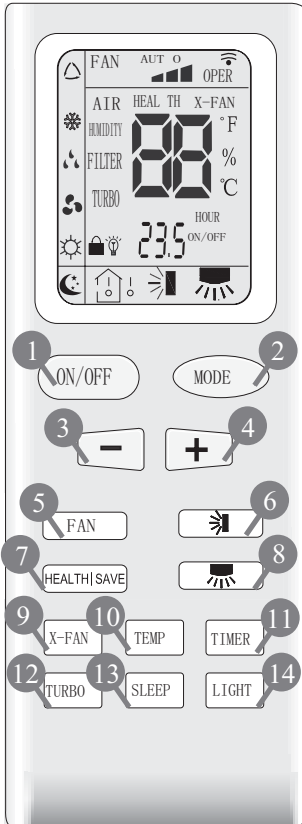





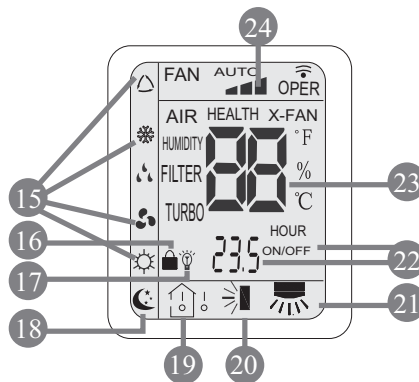

6. Function and Control

6.1 Remote Controller Description



- 1 ON/OFF**
Press it to start or stop operation.
- 2 MODE**
Press it to select operation mode (AUTO/COOL/DRY/FAN/HEAT).
- 3 -**
Press it to decrease temperature setting.
- 4 +**
Press it to increase temperature setting.
- 5 FAN**
Press it to set fan speed.
- 6** 
Press it to set swing angle.
- 7 HEALTHSAVE**
Press it to turn on or off health function.
- 8** 
Press it to set left & right swing angle.
- 9 X-FAN**
- 10 TEMP**
- 11 TIMER**
Press it to set timer ON/ timer OFF.
- 12 TURBO**
- 13 SLEEP**
- 14 LIGHT**
Press it to turn on/off the light.



- 15 MODE icon:**
If MODE button is pressed, current operation mode icon  (AUTO),  (COOL),  (DRY),  (FAN) or  (HEAT is only for heat pump models) will show.
- 16 LOCK icon:**
 is displayed by pressing "+" and "-" buttons simultaneously. Press them again to clear the display.
- 17 LIGHT icon:**
 is displayed by pressing the LIGHT button. Press LIGHT button again to clear the display.
- 18 SLEEP icon :**
 is displayed by pressing the SLEEP button. Press this button again to clear the display.
- 19 TEMP icon:**
Pressing TEMP button,  (set temperature),  (ambient temperature),  (outdoor ambient temperature) and blank is displayed circularly.

20 Up & down swing icon:

is displayed when pressing the up & down swing button. Press this button again to clear the display.

21 Left & right swing icon:

is displayed when pressing the left & right swing button. Press this button again to clear the display.

22 SET TIME display:

After pressing TIMER button, ON or OFF will blink. This area will show the set time.

23 DIGITAL display:

This area will show the set temperature. In SAVE mode, "SE" will be displayed. During defrosting operation, "H1" will be displayed.

24 FAN SPEED display:

Press FAN button to select the desired fan speed setting (AUTO, Low, Med, High). Your selection will be displayed in the LCD windows, except the AUTO fan speed.

1 ON/OFF:

Press this button to turn on the unit. Press this button again to turn off the unit.

2 MODE:

Each time you press this button, a mode is selected in a sequence that goes from AUTO, COOL, DRY, FAN, and HEAT *, as the following:



*Note: Only for models with heating function.

After energization, AUTO mode is defaulted. In AUTO mode, the set temperature will not be displayed on the LCD, and the unit will automatically select the suitable operation mode in accordance with the room temperature to make indoor room comfortable.

3 + :

Press this button to increase set temperature. Hold it down for above 2 seconds to rapidly increase set temperature. In AUTO mode, set temperature is not adjustable.

4 -:

Press this button to decrease set temperature. Hold it down for above . 2 seconds to rapidly decrease set temperature. In AUTO mode, set temperature is not adjustable.

5 FAN :

This button is used for setting fan speed in the sequence that goes from AUTO, Low speed, Medium speed, High speed to then back to Auto.

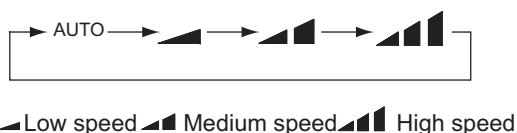

6 Fan Swing Icon:

- Press Fan Swing button to start or stop up & down swing function. The remote controller defaults to simple swing condition.
- Press + button and Fan Swing button at the same time at unit OFF to switch between simple swing and static swing; Fan Swing icon blinks for 2 seconds.
- In static swing condition, pressing Fan Swing button, the swing angle of up & down louver changes as below:



• If the unit is turned off during swing operation, the louver will stop at present position.

7 HEALTH/SAVE:

Press HEALTH part of this button to turn on or off HEALTH function. Pressing SAVE part of this button, HEALTH icon is displayed and the unit goes into SAVE operation mode. Press SAVE part of the button again to cancel SAVE function. During SAVE operation, the temperature and fan speed is not adjustable.

8 Left & Right Swing Icon (Not available for this unit)

- Press Left & Right Swing button to start or stop left & right swing function. The remote controller defaults to simple swing condition.
- Press + button and Left & Right Swing button at the same time at unit OFF to switch between simple swing and static swing; Left & Right Swing icon blinks for 2 seconds.

- In static swing condition, pressing  button, the swing angle of left & right louver changes as below:

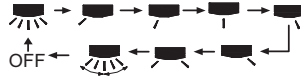

- If the unit is turned off during swing operation, the louver will stop at present position.

9 X-FAN:

Pressing X-FAN button in COOL or DRY mode, the icon "X-FAN" is displayed and the indoor fan will continue operation for 10 minutes in order to dry the indoor unit even though you have turned off the unit. After energization, X-FAN OFF is defaulted. X-FAN is not available in AUTO, FAN and HEAT mode.

10 TEMP:

Press this button, could select displaying the indoor setting temperature or indoor ambient temperature. When the indoor unit firstly power on it will display the setting temperature, if the temperature's displaying status is changed from other status to "  ", displays the ambient temperature, 5s later or within 5s, it receives other remote control signal that will return to display the setting temperature. If the users haven't set up the temperature displaying status, that will display the setting temperature.

11 TIMER:

Press TIMER button at unit ON to set TIMER OFF; HOUR OFF blinks. Press TIMER button at unit OFF to set TIMER ON; HOUR ON blinks. In this case, pressing + or - button changes time setting. Holding down either button rapidly changes time setting (time setting range 0.5-24hours). Press TIMER button again to confirm setting; HOUR ON/OFF stops blinking. If there is not any operation of button within 5 seconds during HOUR ON/OFF blinking, TIMER setting will be cancelled.



12 TURBO:

Press this button to activate / deactivate the Turbo function which enables the unit to reach the preset temperature in shortest time. In COOL mode, the unit will blow strong cooling air at super high fan speed. In HEAT mode, the unit will blow strong heating air at super high fan speed.



13 SLEEP :

Press this button to go into the SLEEP operation mode. Press it again to cancel this function. This function is available in COOL , HEAT (Only for models with heating function) or DRY mode to maintain the most comfortable temperature for you.

14 LIGHT:

Press LIGHT button to turn on the display's light and press this button again to turn off the display's light. If the light is turned on,  is displayed. If the light is turned off,  disappears.

15 Combination of "+" and "-" buttons: About lock

Press "+" and "-" buttons simultaneously to lock or unlock the keypad. If the remote controller is locked,  is displayed. In this case, pressing any button,  blinks three times.

16 Combination of "MODE" and "-" buttons: About switch between Fahrenheit and Centigrade. At unit OFF, press "MODE" and "-" buttons simultaneously to switch between $^{\circ}\text{C}$ and $^{\circ}\text{F}$.

6.2 Changing Batteries and Notices

1. Slightly to press the place with , along the arrowhead direction to push the back cover of wireless remote control. (As show in figure)
2. Take out the old batteries. (As show in figure)
3. Insert two new AAA1.5V dry batteries, and pay attention to the polarity. (As show in figure)
4. Attach the back cover of wireless remote control. (As show in figure)

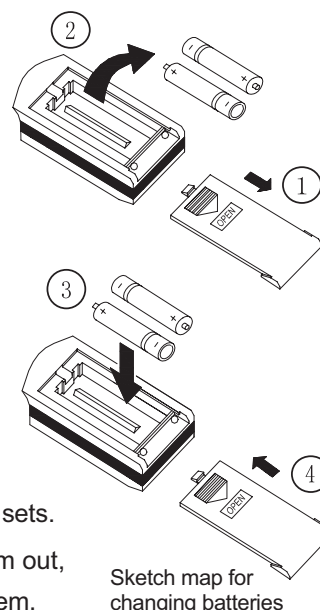

★ NOTE:

- When changing the batteries, do not use the old or different batteries, otherwise, it can cause the malfunction of the wireless remote control.
- If the wireless remote control will not be used for a long time, please take them out, and don't let the leakage liquid damage the wireless remote control.
- The operation should be in its receiving range.
- It should be placed at where is 1m away from the TV set or stereo sound sets.
- If the wireless remote control can not operate normally, please take them out, after 30s later and reinsert, if they cannot normally run, please change them.

6.3 Unit Indication Section

1. When the unit is energized, all the display marks will be shown and only the power LED lights.
2. When the unit is turned on remotely, the power LED goes out while the current setting running mode is displayed.
3. During defrosting, "H1" is displayed in "dual 8".
4. In normal situation, the setting temperature is displayed in "dual 8" place.
5. When the signal of displaying indoor temperature or outdoor temperature is received from the controller, the corresponding temperature will be shown in "dual 8" place. It resumes displaying setting temperature 5s later.

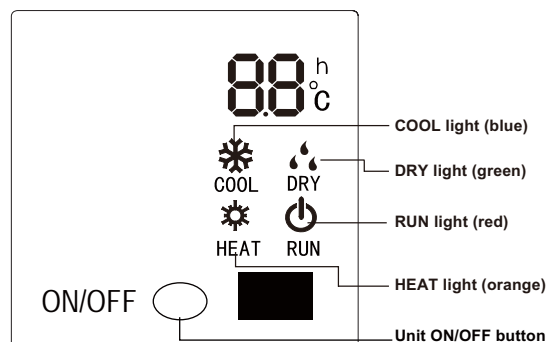

6.4 Unit ON/OFF Button

If the wireless remote control is lost or broken, please use the manual switch button. At this time, the unit will run at the Auto mode, but the temperature and fan speed cannot be changed. The operation was shown as below:

To open the panel, the manual switch is on the displayer box.

- Turn on the unit: At unit turned off, press the button, the unit will run at Auto mode immediately. The microcomputer will accord to the indoor temperature to select (Cooling, Heating, Fan) and obtain the comfortable effect.
- Turn off the unit: At unit turned on, press the button, the unit will stop working.

Operation of automatic buttons:

	Less than 5s	Keep 5 ~ 10 s	Keep more than 10s
Operation during stop	●Start running	●Start compulsory running	●Stop compulsory running (avoid button lock)
Operation during running	●Stop running	●Stop running	-
Operation during stop communication error	- (after running, abnormal)		

6.5 Description of Each Control Operation

Indoor Unit

Temperature Parameter

- ◆ Room setting temperature (T_{preset})
- ◆ Room ambient temperature ($T_{\text{amb.}}$) (temperature sensor :15K, partial pressure resistance:15K)
- ◆ Surface temperature of copper pipe for indoor heat exchanger ($T_{\text{indoor tube}}$) (temperature sensor: 20K, partial pressure resistance: 20K)

1. Basic Functions of System

(1) Cooling Mode

1. In this mode, indoor fan and swing will operate according to the setting status. The temperature setting range is 16~30°C.(Fahrenheit: 61~86°C).
 2. When the unit stop operation due to malfunction of outdoor unit or protection, indoor unit will keep original operating status. Malfunction code will be displayed.
 3. When $0 \leq (T_{\text{preset}} - T_{\text{amb.}})$, if the indoor unit is operating at high fan speed, the speed of fan will change to medium fan speed; if the indoor unit is operating at medium or low fan speed, the speed of fan will keep the same; (This condition can only be carried out after the compressor is started up);
- Theres no change for super-high fan speed; when $(T_{\text{amb.}} - T_{\text{preset}}) \geq 1^\circ\text{C}$, the fan speed will resume setting fan speed;

(2) Dry Mode

1. In this mode, fan will operate at low fan speed and swing will operate at setting status. The temperature setting range is 16~30°C.(Fahrenheit: 61~86°F).
2. When the unit stop operation due to malfunction of outdoor unit or protection, indoor unit will keep original operating status. Malfunction code will be displayed.

(3) Fan Mode

1. In this mode, indoor fan will operate at high, medium, low or auto fan speed. Compressor, indoor fan and the four-way valve will all stop operation.
2. In this mode, the temperature setting range is 16~30°C.(Fahrenheit: 61~86°F).

(4) Heating Mode

1. In this mode, the temperature setting range is 16~30°C. (Fahrenheit: 61~86°F).
2. Working condition and process of heating: when the unit is turned on in heating mode, indoor unit enters into anti-cold air condition; when the unit is tuned off, the unit will enter into the condition of blowing residual heat.
3. Protection function: in heating mode, when the compressor is stopped due to malfunction, indoor fan will operate at the condition of blowing residual heat.
4. Defrosting control: after receiving the defrosting signal from outdoor unit, the defrosting code H1 will be displayed.
5. Anti-cold function
6. Blowing residual heat function;
 - a. During heating operation, when the stopping condition for the compressor is reached, the compressor and the outdoor fan motor stop operation. The upper& down horizontal louver will rotate to the horizontal position L. The indoor fan will be stopped after operating for 60s at setting speed.
 - b. Due to the blockage of PG motor, horizontal louver will keep the stop position when the unit is turned off. (In other modes) When the unit is stopped due to other malfunctions, up&down horizontal louver will rotate to horizontal position L. The indoor fan will be stopped after operating for 60s at setting speed.
 - c. If the unit is turned off when the compressor is operating in heating mode or auto heating mode, up&down horizontal louver will rotate to horizontal position L. The indoor fan will be stopped after operating for 60s at setting speed.

(5) Auto Mode

1. When $T_{\text{amb.}} \geq 26^\circ\text{C}$, the unit will operate in cooling mode. The implied setting temperature is 25°C. ((Fahrenheit: 77°F).
2. Heat pump type: when $T_{\text{amb.}} \leq 22^\circ\text{C}$, the unit will operate in heating mode. The implied setting temperature is 20°C. (Fahrenheit: 68°F).
3. Cooling only unit: when $T_{\text{amb.}} \leq 25^\circ\text{C}$, the unit will operate in auto mode. The implied setting temperature is 25°C. (Fahrenheit: 77°F).
4. When $23^\circ\text{C} \leq T_{\text{indoor amb.}} \leq 25^\circ\text{C}$, the unit will operate in auto fan mode if the unit is turned on and enters into the auto mode for the first time. If the unit is switched to auto mode from other mode, it will keep the previous operation mode (if the unit is switched to auto mode from dry mode, the unit will operate at auto fan mode).

2. Display Status of Indoor Indicator

(1) Status of Indoor Display Board

1. After energization, all the icons will be displayed and then only the power indicator is bright. When the unit is turned on by remote controller, the operation indicator will be bright. Meanwhile, the current setting operation mode will be displayed.
2. During defrosting, "dual-8" will display "H".
3. "Dual-8" displays setting temperature.

➤Display of Operation Icon and Mode Icon

After energization, all the icons will be displayed for once. In standby status, the operation indicator will be in red. If turn on the unit by remote controller, the operating indication icon will be bright. Meanwhile, the current setting operation mode will be displayed (mode indicator: cooling indicator, heating indicator, dry indicator). If turn off the light button, all displays will be turned off.

➤Temperature display control mode for split type unit

1. When user set the remote controller as the setting temperature display status, the current setting temperature will be displayed on remote controller.
2. Only when the remote control signal is switched to indoor ambient temperature display status from other display status, controller will display the indoor ambient temperature for 5s and then turn back to display the setting temperature.
3. When user hasnt set the temperature displaying status, it will be displayed according to the setting temperature.

(2)Malfunction Display of Indoor Unit

When multiple malfunctions occurred simultaneously, malfunction protection codes will be displayed in cycle.

3. Other Control Target

(1) Up&down swing function: the mode for swing motor is MP28EA

After energization, up & down swing motor will firstly let the horizontal louver anticlockwise rotate to position 0 to close air outlet.

If swing function has not been set after startup of the unit, up & down horizontal louver will clockwise turn to position D in HEAT mode, or clockwise turn to level position L in other modes.

If setting swing function while starting up the unit, the horizontal louver will swing between L and D.

There are 7 kinds of swing status of horizontal louver: Positions L, A, B, C and D, swing between L and D and stop at any position between L and D.

Upon turning off the unit, the horizontal louver will close at position 0. Swing function is available only when swing function set and indoor fan is operating.

Note: If the position is set between L and B, A and C or B and D by remote controller, the horizontal louver will swing between L and D.
L----A----B----C----D

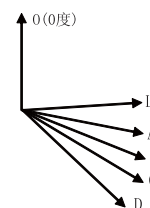

(2) Buzzer

Upon energization and operation, the buzzer will give out sound.

(3) Auto Button

After pressing this button, the unit will operate in auto mode. Indoor fan will operate at auto fan speed and swing motor will operate. Press this button again to turn off the unit. The complete unit is energized when pressing the button and the complete unit will enter into fast testing status. After energization, if its detected that the auto button is pressed down and the complete unit is at fast testing status, the fast testing status will be exited.

(4) Sleep Function

This mode is only valid in cooling and heating mode. The unit will select the appropriate sleeping curve to operate according to the different setting temperature.

During cooling mode:

(1) When the initial temperature is set as 16~23°C, after starting up the sleep function, the temperature will increase by 1°C every one hour. After the temperature has increased by 3°C, the unit will keep this temperature. When the unit has operated for 7 hours, the temperature will decrease by 1°C and then the unit will operate at this temperature all the time;

(2) When the initial temperature is set as 24~27°C, after starting up the sleep function, the temperature will increase by 1°C every one hour. After the temperature has increased by 2°C, the unit will keep this temperature. When the unit has operated for 7 hours, the temperature will decrease by 1°C and then the unit will operate at this temperature all the time;

(3) When the initial temperature is set as 28~29°C, after starting up the sleep function, the temperature will increase by 1°C every one hour. After the temperature has increased by 1°C, the unit will keep this temperature. When the unit has operated for 7 hours, the temperature will decrease by 1°C and then the unit will operate at this temperature all the time;

(4) When the initial temperature is set as 30°C, the unit will operate at this temperature. After the unit has operate for 7hours, the temperature will decrease by 1°C and then the unit will operate at this temperature all the time.

During Heating Mode:

(1) When the initial temperature is set at 16°C, the unit will operate at this temperature all the time;

(2)When the initial temperature is set as 17~20°C, after starting up the sleep function, the temperature will decrease by 1°C every one hour. After the temperature is decreased by 1°C, the unit will operate at this temperature;

(3)When the initial temperature is set as 21~27°C, after starting up the sleep function, the temperature will decrease by 1°C every one hour. After the temperature is decreased by 2°C, the unit will operate at this temperature;

(3)When the initial temperature is set as 28~30°C, after starting up the sleep function, the temperature will decrease by 1°C every one hour. After the temperature is decreased by 3°C, the unit will operate at this temperature;

General timer and clock timer functions are compatible by equipping different functions of remote controller.

(5) Timer Function

General timer and clock timer functions are compatible by equipping different functions of remote controller.

General timer:

Timer ON

If timer ON is set during operation of the unit, the unit will continue to operate. If timer ON is set at unit OFF, upon ON time reaches the unit will start to operate according to previous setting status.

Timer OFF

If timer OFF is set at unit OFF, the system will keep standby status. If timer OFF is set at unit ON, upon OFF time reaches the unit will stop operation.

(6) Blow Function

Blow function can be set in cooling and dry mode.

(7) Indoor Fan Control

Indoor fan can be set at super-high, high, medium or low. Meanwhile, the fan will operate at super-high, high, medium and low fan speed respectively and it can also set at auto fan speed.

(8) Memory Function

Memory content includes mode, up & down swing, light, set temperature and set fan speed, general timer (clock timer cant be memorized), Upon power failure, the unit after power recovery will automatically start operation according to memorized content. The unit, without timer setting before power failure, will operate according to the last setting after power recovery. The unit, with general timer setting which has not been fulfilled before power failure, will memorize the time setting and re-calculate the time after power recovery. If there is timer function in the last remote controller command but setting time has reached, the system will act as timer on/off setting before power failure. After power failure, the system memorizes the operation states before power failure without timer action. Clock timer can not be memorized.

(9) Locked protection to PG motor

If the indoor fan motors rotational speed after startup keeps slow for a continuous period of time, the unit will stop operation and display "H6".

(10) Turbo Function

This function can be set in cooling or heating mode to quickly cool or heat the room(Turbo function is not available in auto, dry and fan mode). After pressing the turbo button, indoor fan will operate at super-high fan speed.

5. Malfunction Detection for Temperature sensor

(1) Indoor ambient temperature sensor:

Malfunction of temperature sensor will be detected at any time;

(2) Indoor tube temperature sensor

Malfunction of temperature sensor wont be detected during defrosting period. It starts detecting the malfunction of temperature sensor after defrosting is finished for 5 mins. Malfunction of temperature sensor will be detected at any other time.

(3) Protection of temperature sensor

1. When the temperature sensor is detected short circuit for 30s successively:

The detected temperature by the temperature sensor is too high and the complete unit will stop operation, meanwhile, the protection and malfunction of temperature sensor will be displayed accordingly.

2. When the temperature sensor is detected open circuit for 30s successively: The unit will stop operation due to protection and the corresponding malfunction of temperature sensor will be displayed directly.

6. Compulsory operating function of indoor unit

(1) Enter into compulsory operation control

After the unit is energized for 5mins, press the light button on remote controller for 3 times in 3s successively to enter into Freon recovery mode. Fo will be displayed. When Freon recovery mode operated for 25mins, all loads will operate in cooling mode. (The setting fan speed is high fan speed and the setting temperature is 16°C)

(2) Exit the compulsory operation control

Freon recovery mode will be exited after receiving any signal from remote controller or button and then the unit will operate at the current setting command; Freon mode will also be exited after operating for 25mins and then the unit will be turned off.

Outdoor Units

1. Input Parameter Compensation and Calibration

(1) Check the input parameter compensation function

As the instruction feature of split unit, concerning the comfortable, in heating mode, the indoor ambient temperature of compressor stopping time is higher than preset temperature.

(2) Check effective judgment controls of parameters

Effective judgment function of the outdoor exhaust temperature thermo-bulb

When conditions a and b are satisfied, the outdoor exhaust temperature thermo-bulb is judged not to be connected into place, the mainboard of outer units will display failure of the outdoor exhaust temperature thermo-bulb (not connected into place), stop the unit for repairing, and resume it by remote controls of ON/OFF.

2. Basic Functions

(1) Cooling Mode

1. Conditions and processes of cooling operation:

(1) If the compressor is stop, and $[T_{\text{preset}} - (T_{\text{indoor ambient}} - \Delta T_{\text{cooling indoor ambient temperature compensation}})] \leq 0.5^{\circ}\text{C}$, start up the unit for cooling, and start to cooling operation;

(2) During operations of cooling, if $0^{\circ}\text{C} \leq [T_{\text{preset}} - (T_{\text{indoor ambient}} - \Delta T_{\text{cooling indoor ambient temperature compensation}})] < 2^{\circ}\text{C}$, the cooling operation will be still running;

(3) During operations of cooling, if $2^{\circ}\text{C} \leq [T_{\text{preset}} - (T_{\text{indoor ambient}} - \Delta T_{\text{cooling indoor ambient temperature compensation}})]$, the cooling operation will stop after reaching to the temperature point.

2. Temperature setting range

- (1) If $T_{\text{outdoor ambient}} \geq [T_{\text{low-temperature cooling}}]$, the temperature can be set at: 16~30°C (Cooling at room temperature);
- (2) If $T_{\text{outdoor ambient}} < [T_{\text{low-temperature cooling}}]$, the temperature can be set at: 25~30°C (Cooling at low temperature), that is, the minimum setting temperature for outdoor unit judgment is 25°C.

(2) Dry Mode

1. Conditions and processes of dry operations: Same as the cooling mode;
2. The temperature setting range is: 16~30°C;

(3) Fan Mode

1. The compressor, outdoor fan and four-way valve are switched off;
2. The temperature setting range is: 16~30°C.

(4) Heating Mode

1. Conditions and processes of heating operations: ($T_{\text{indoor ambient}}$ is the actual detection temperature of indoor environment thermo-bulb, $\Delta T_{\text{heating indoor ambient temperature compensation}}$ is the indoor ambient temperature compensation during heating operations)

(1) If the compressor is stop, and $[(T_{\text{indoor ambient}} - \Delta T_{\text{heating indoor ambient temperature compensation}}) - T_{\text{preset}}] \leq 0.5^{\circ}\text{C}$, start the machine to enter into heating operations for heating;

(2) During operations of heating, if $0^{\circ}\text{C} \leq [(T_{\text{indoor ambient}} - \Delta T_{\text{heating indoor ambient temperature compensation}}) - T_{\text{preset}}] < 2^{\circ}\text{C}$, the heating operation will be still running;

(3) During operations of heating, if $2^{\circ}\text{C} \leq [(T_{\text{indoor ambient}} - \Delta T_{\text{heating indoor ambient temperature compensation}}) - T_{\text{preset}}]$, the heating operation will stop after reaching the temperature point.

2. The temperature setting range in this mode is: 16~30°C.

(5) Defrosting Control

1. After the time for defrosting is judged to be satisfied, if the temperature for defrosting is satisfied after detections for continuous 3minutes, the defrosting operation will start.

2. Start to defrost: Compressor stops and starts up 55S later;

3. Defrosting finish: Compressor stops and starts up 55S later;

4. Conditions of finishing defrosting

The defrosting operation can exit when any of the conditions below is satisfied:

(1) $T_{\text{outdoor pipe}} \geq 12^{\circ}\text{C}$;

(2) $T_{\text{outdoor ambient}} < -5^{\circ}\text{C}$, and the $T_{\text{outdoor pipe}} \geq 6^{\circ}\text{C}$ last more than 80S;

(3) The continuous running time of defrosting reaches to 8min.

(6) Compressor Control

1. The frequency of compressor will be controlled with the relationship of ambient temperature and preset temperature and changing speed of ambient temperature;

2. Start the compressor after starting cooling, heating, dry operations, and the outdoor fan start for 5s;

3. When the unit is off, in safety stops and switching to fan mode, the compressor will stop immediately;

4. In all modes: once the compressor starts up, it will not be allowed to stop until having run for the $[T_{\text{min. Compressor running time}}]$ (Note: including cases of shutdown when the temperature point is reached; except the cases requiring stopping the compressor such as fault protection, remote shutdown, mode switching etc.);

5. In all modes: once the compressor stops, it will be allowed be restart after 3-minute delay (Note: The indoor units have a function of power memory, the machine can be restarted after remote shutdown and powering up again without delay).

(7) Outdoor Fan Control

1. When the unit is off by remote control, in safety stops and stop after reaching to the temperature point.

2. In fan mode: The outdoor fan stops;

3. Start to defrost: Outdoor fan will stop after compressor stops for 50S;

4. Defrosting finish: Outdoor fan will start up when the compressor is stopping.

(8) 4-way valve control

1. The 4-way valve control under the modes of Cooling, dehumidification and fan: closing;

2. When the unit is on in heating mode, the 4-way valve is energized;

3. When the unit is on in heating mode and heating mode shift to other modes, the 4-way valve will be de-energized after compressor stops for 2min;

4. After protection stops, the 4-way valve will be de-energized after 4min;

5. Start to defrost: The power of 4-way valve will be de-energized after the compressor stops;

6. Defrosting finish: The 4-way valve will be energized after the compressor stops.

(9) Current protection

1. If $12A \leq I_{\text{alternating-current}}$, running frequency of compressor will be decreased or stop to increase will be occurred;
2. If $17A \leq I_{\text{alternating-current}}$, the unit will stop; and compressor has stopped for 3min, the unit will resume running;
3. If the unit stops as compressor discharge temperature for 6 times, it can not resume running automatically and display malfunction, it can resume by pressing ON/OFF. During operation, if the time exceeds compressor running time, the time of compressor discharge temperature stop will zero clearing.

(10) Drop off voltage

During compressor operation, the system will stop and malfunction of drop off voltage if voltage downward fluctuates rapidly, and it will re-start up automatically 3min later.

(11) Communication malfunction

If the unit does not receive correct signal from indoor unit for 3min continuously, the unit will stop as communication malfunction protection; if communication malfunction resume and compressor has stopped for 3min, the unit will resume running.

(12) IPM module protection

When the compressor starts, if there is overcurrent or control voltage low for IPM module as some abnormal results, IPM will detect module protection signal as the unit is on. Once the module protective signal is detected, stop the unit with module protection immediately. If the module protection is resumed and compressor has stopped for 3min, the unit will be allowed to operate. If the module protection continuously occurs for three times, it should not be resumed automatically, and you should press the ON/OFF button to resume. If the running time of compressor exceeds the [$t_{\text{Protection times clearing of module}}$], the module protection is cleared to recount.

(13) Compressor overload protection

1. If the switch of compressor overload de-energized is detected for 3S continuously, the system will stop as protection;
2. If the overload protection is resumed and compressor has stopped for 3min, the unit will be allowed to operate.
3. If the unit stops as compressor overload protection occurred for 3 times continuously, it can not resume running automatically and display malfunction, it can resume by pressing ON/OFF; and the times of compressor overload protection will be cleared after the compressor has run for 30min.

7. Installation Manual

Important Notices

1. The unit installation work must be done by qualified personnel according to the local rules and this manual.
2. Before installing, please contact with local authorized maintenance center, if unit is not installed by the authorized maintenance center, the malfunction may not solved, due to discommodious contacts.
3. When removing the unit to the other place, please firstly contact with the authorized Maintenance Center in the local area.

Basic Requirements For Installation Position

Install in the following place may cause malfunction. If it is unavoidable contact with service center please:

- * Place where strong heat sources, vapors, flammable gas or volatile object are emitted.
- * Place where high-frequency waves are generated by radio equipment, welders and medical equipment.
- * Place where a lot of salinities such as coast exists.
- * Place where the oil (machine oil) is contained in the air.
- * Place where a sulfated gas such as the hot spring zones is generated.
- * Other place with special circumstance.

7.1 Tools Required for Installation (not supplied)

1. Gauge manifold
2. Electronic balance for refrigerant charging
3. Phillips head screwdriver
4. Knife or wire stripper
5. Carpenters level
9. Hammer
10. Drill
11. Tube cutter
12. Tube flaring tool
13. Torque wrench
14. Adjustable wrench
15. Reamer (for deburring)
16. Vacuum pump (For R410A)
17. Gas leakage detector

7.2 Installation Position Selection

1. Indoor Unit

- (1)The air inlet and outlet vent should be far from the obstruction, make sure that the air can be blown through the whole room.
- (2)Select a position where the condensing water can be easily drained out, and the place is easily connected for outdoor unit.
- (3)Select a location where the children can not reach.
- (4)Can select the place where is strong enough to withstand the full weight and vibration of the unit. And will not increase the noise.
- (5)Be sure to leave enough space to allow access for routine maintenance. The height of the installed location should be 250cm or more from the floor.
- (6)Select a place about 1m or more away from TVset or any other electric appliances.
- (7)Select a place where the filter can be easily taken out.
- (8)Make sure that the indoor unit installation should accord with installation dimension diagram requirements.
- (9)Do not use the unit in the immediate surroundings of a laundry a bath a shower or a swimming pool.

2. Outdoor Unit

- (1)Select a location from which noise and outflow air emitted by unit will not inconvenience neighbors, animals, plants.
- (2)Select a location where there should be sufficient ventilation.
- (3)Select a location where there should be no obstructions cover the inlet and outlet vent.
- (4)The location should be able to withstand the full weight and vibration of the outdoor unit and permit safe installation.
- (5)Select a dry place, but do not expose under the direct sunlight or strong wind.
- (6)Make sure that the outdoor unit installation dimension should accord with installation dimension diagram, convenient for maintenance, repair.
- (7)The height difference of connecting the tubing within 5m, the length of connecting the tubing within 10m.
- (8)Select a place where it is out of reach for the children.
- (9)Select a place where will not block the passage and do not influence the city appearance.

7.3 Installation of Indoor Unit

1. Installing the mounting plate

The mounting plate should be installed on a wall which can support the weight of the indoor unit.

- 1) Temporarily secure the mounting plate to the wall, make sure that the panel is completely level, and mark the boring points on the wall.
- 2) Secure the mounting plate to the wall with screws.

Recommended mounting plate retention spots and dimensions

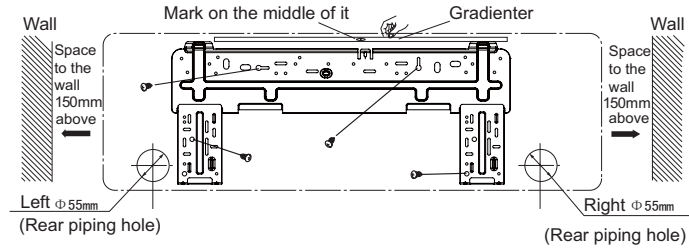

2. Boring a wall hole and installing wall pipe

• Be sure to caulk the gaps around the pipes with caulking material to prevent water leakage.

- 1) Bore a feed-through hole of 55mm in the wall so it has a down slope toward the outside.
- 2) Insert a wall pipe into the hole.
- 3) After completing refrigerant piping, wiring, and drain piping, caulk pipe hole gap with putty.

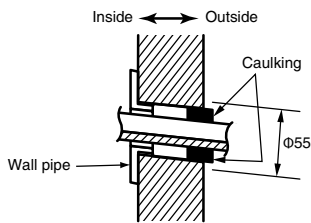

3. Flaring work and connection of piping

3.1 Flaring work

Flaring work

Main cause for refrigerant leakage is due to defect in the flaring work. Carry out correct flaring work using the following procedure.

Cut the pipes and the cable

1. Use the piping kit accessory or pipes purchased locally.
2. Measure the distance between the indoor and the outdoor unit.
3. Cut the pipes a little longer than the measured distance.
4. Cut the cable 1.5m longer than the pipe length.

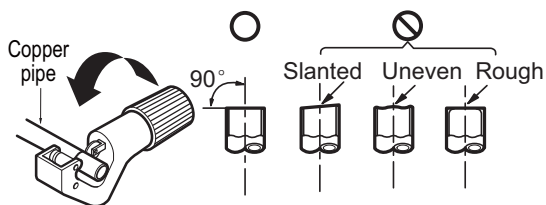

Burr removal

1. Completely remove all burrs from the cut cross section of pipe/tube.
2. Put the end of the copper tube/pipe in a downward direction as you remove burrs in order to avoid dropping burrs into the tubing.

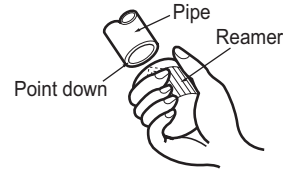

Putting nut on

Remove flare nuts attached to indoor and outdoor unit, then put them on pipe/tube having completed burr removal. (not possible to put them on after flaring work)

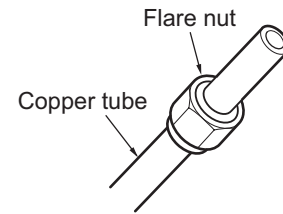

Flaring work

Firmly hold copper pipe in a die in the dimension shown in the table above.

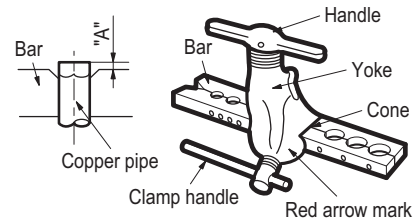

Carry out flaring work using flaring tool as shown below.

Outside diameter		A
mm	inch	mm
Ø6	1/4	0~0.5
Ø9.52	3/8	0~0.5
Ø12	1/2	0~0.5
Ø16	5/8	0~1.0
Ø19	3/4	1.0~1.3

Check

1. Compare the flared work with figure below.
2. If flare is noted to be defective, cut off the flared section and re-flare it.

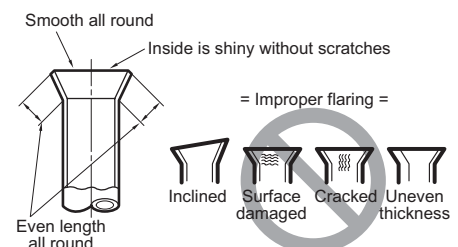

3.2 Connection of piping

1. Align the center of the pipes and sufficiently tighten the flare nut by hand.

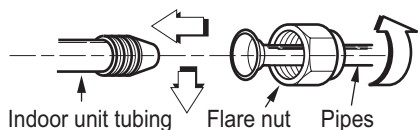

2. Tighten the flare nut with a wrench.

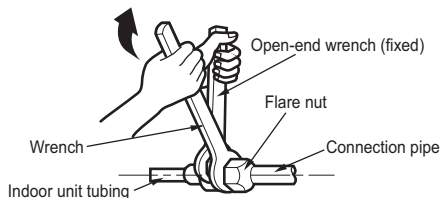

Outside diameter		Torque kg·m
mm	inch	
Ø6.35	1/4	1.8
Ø9.52	3/8	4.2
Ø12.7	1/2	5.5
Ø15.88	5/8	6.6
Ø19.05	3/4	6.6

4. Drain hose junction

If drain hose extension or embedded drain piping is required, use appropriate parts that match the hose front end.

Insert drain hose into the handle of drain pan, and join drain hose and connecting hose according to the figure by.

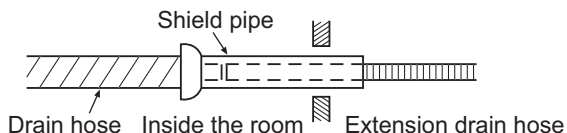

CAUTION

Insert the drain hose and drain cap into the drain port, making sure that it comes in contact with the back of the drain port, and then mount it. If the drain hose is not connected properly, leaking will occur.

- Attach the Insulation (Drain hose) to the drain hose.

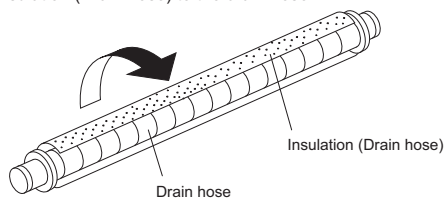

5. Wiring Connection

Wiring the connecting cable can be carried out without removing the front panel.

1. Remove the front panel. Open the front panel upward and pull it toward you.
2. Remove the terminal cover and cord clamp.
3. Insert the connecting cable (or as according to local regulations/codes) into the pipe hole on the wall.
4. Pull the connecting cable through the cable slot on the rear case so that it protrudes about 15cm out of the front.

5. Insert the connecting cable fully into the terminal block and secure it tightly with screws.
6. Tightening torque: 1.2 N·m (0.12 kgf·m).
7. Secure the connecting cable with the cord clamp.
8. Attach the terminal cover and front panel on the indoor unit.

CAUTION

- Be sure to refer to the wiring system diagram labeled inside the front panel.
- Check local electrical regulations for any specific wiring instructions or limitations.

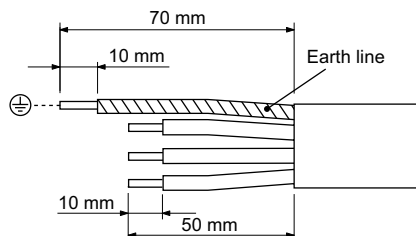
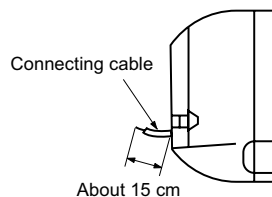
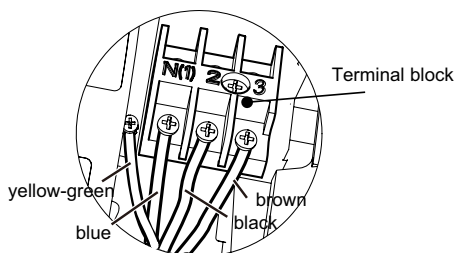
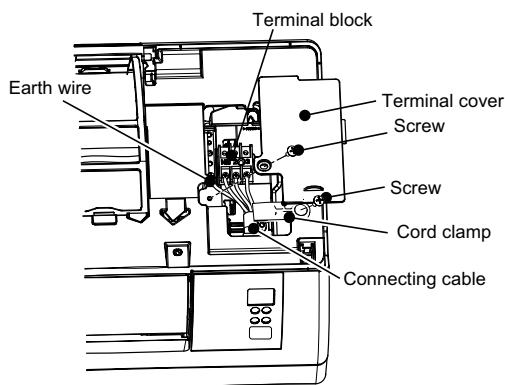

6. Installing indoor unit

In the case of bending or curing refrigerant pipes, keep the following precautions in mind.

Abnormal sound may be generated if improper work is conducted.

- 1) Do not strongly press the refrigerant pipes onto the bottom frame.
- 2) Do not strongly press the refrigerant pipes on the front grille, either.

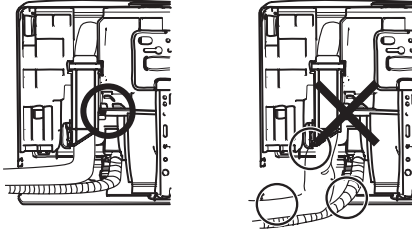

The piping can be lead out from right, right rear, left left rear.

Right-side, right-back, or right-bottom piping

1) After making slits on the front panel with a knife or similar tool, cut them out with a pair of nippers or an equivalent tool.

Attach the drain hose to the underside of the refrigerant pipes with an adhesive vinyl tape.

2) Wrap the refrigerant pipes and drain hose together with an insulation tape.

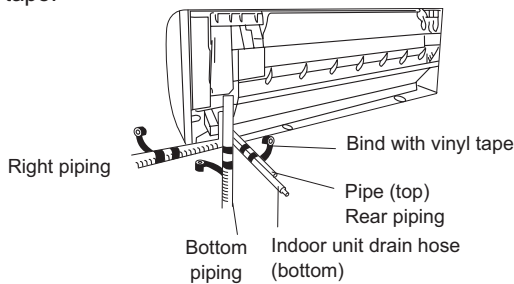

Left-side, left-back, or left-bottom piping

• Interchange the drain cap and the drain hose.

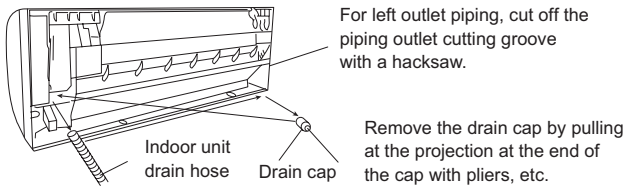

CAUTION

- (1) In order to align the drain hose and drain cap, be sure to insert securely and vertically. Incline insertion will cause water leakage.
- (2) When inserting, be sure not to attach any material besides water. If any other material is attached, it will cause deterioration and water leakage.
- (3) After removing drain hose, be sure not to forget mounting drain cap.
- (4) Be sure to fix the drain hose with tape to the bottom of piping.

(5) Prevent drain water frozen under low temperature environment.

When installing indoor unit's drain hose outdoors, necessary measure for frost protection should be taken to prevent drain water frozen.

- Under low temperature environment (when outdoor temperature under 32 °F), after cooling operation is executed, water in the drain hose could be frozen. Once drain water is frozen, the drain hose will be blocked and water leakage may be resulted for indoor unit.

How to replace the drain plug and drain hose

• How to remove the drain cap

Clamp drain cap with needle-nose pliers, and pull out.

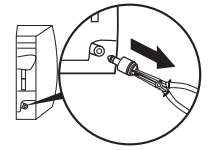

• How to remove the drain hose

The drain hose is secured in place by a screw. Remove the screw securing the drain hose, then pull out the drain hose.

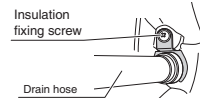

• How to attach the drain cap

1. Insert hexagonal wrench (4 mm).

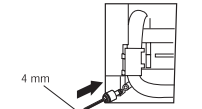

2. Firmly insert drain cap.

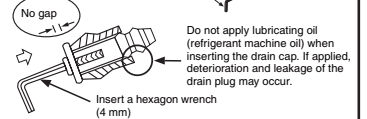

• How to attach the drain hose

Insert the drain hose firmly until the connector contacts the insulation, then secure it in place using the original screw.

1. After making slits on the front panel with a knife or similar tool, cut them out with a pair of nippers or an equivalent tool.

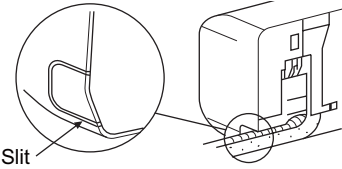

2. Overlap the connection pipe insulation material and the indoor unit pipe insulation material. Bind them together with vinyl tape so that there is no gap.

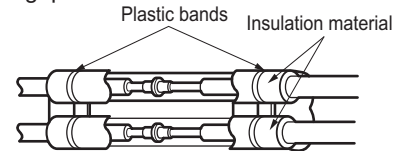

3. Wrap the area which accommodates the rear piping housing section with vinyl tape.

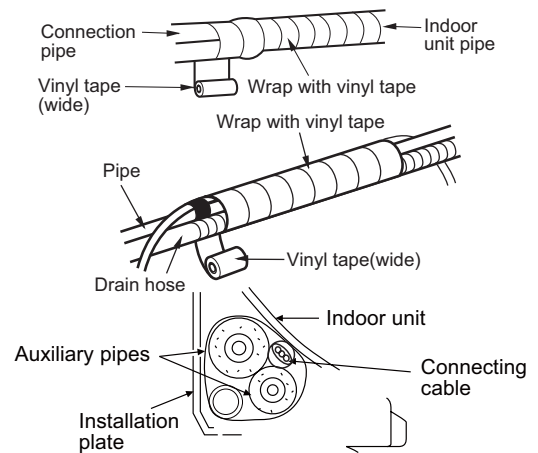

4. Bundle the piping and drain hose together by wrapping them with vinyl tape for enough to cover where they fit into the rear piping housing section.

Indoor unit installation

1) Pass the drain hose and refrigerant pipes through the wall hole, then set the indoor unit on the mounting plate hooks by using the markings at the top of the indoor unit as a guide.

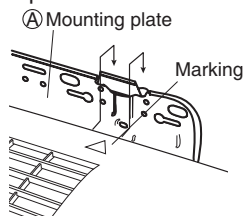

2) Swing the indoor unit to right and left to confirm that it is firmly hooked on the installation plate.

3) While pressing the indoor unit onto the wall, hook it at the lower part on the installation plate.

Pull the indoor unit toward you to confirm that it is firmly hooked on the installation plate.

For detaching the indoor unit from the installation plate pull the indoor unit toward you while pushing the bottom up at the specified places.

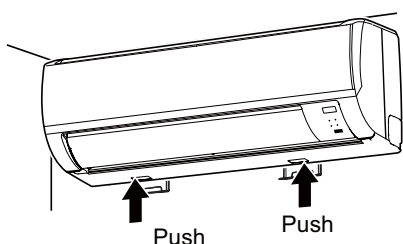

4) Run the drain hose at a downward sloped angle.

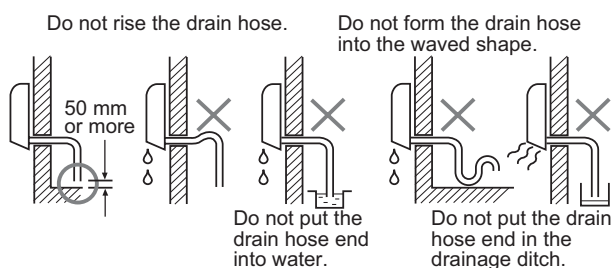

5) Put water in the drain pan and make sure that the water is being drained outside.

Caution:

Install the drain pipe for proper drainage. Improper drainage can result in water dripping inside the room.

7.4 Installation of Outdoor Unit

1. Installation of Outdoor Unit

(1) Install the unit where it will not be tilted by more than 3°. However, do not install the unit with it tilted towards the side containing the compressor.

(2) When installing the outdoor unit where it may exposed to strong wind, fasten it securely.

(3) In the area with heavy snowfall, if the intake and outlet of outdoor unit is blocked with snow it is likely to cause of the breakdown. Please construct a canopy and a pedestal or place the unit on a high stand (local configured)

1. Place the outdoor unit at the selected position in advance.
2. Outdoor unit to be fasten with bolts at the four places indicated by the arrows without fail.

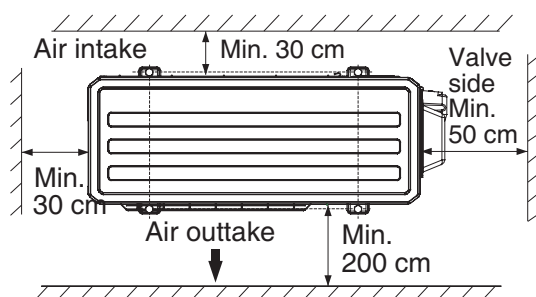

2. Draining the Water(no for cooling only)

* Holes are provided on the base plate of the outdoor unit to ensure that the defrost water produced during heating operations is drained off efficiently.

* If a centralized drain is required when installing the unit on a balcony or wall.

* If the drain port is covered by a mounting base or floor surface, place additional foot bases of at least 30mm in height under the outdoor units feet.

* In cold areas, do not use a drain hose with the outdoor unit. (Otherwise, drain water may freeze, impairing heating performance.)

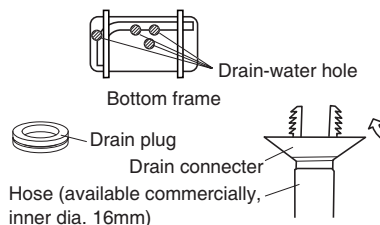

3. Refrigerant Piping Connection

1. Remove the Valve cover from the unit by loosening the screw.

2. Align the center of the pipings and sufficiently tighten the flare nut by hand.

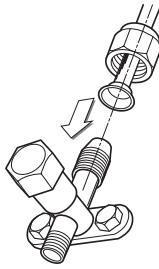

3. Finally, tighten the flare nut with torque wrench until the wrench clicks.

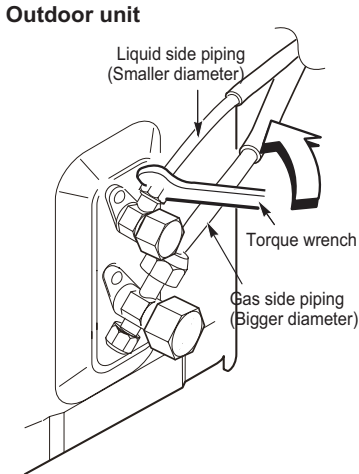

4. Evacuation

After the piping has been connected to the indoor unit, perform the air purge.

AIR PURGE

Evacuate the air in the connecting pipes and in the indoor unit using a vacuum pump.
Do not use the refrigerant in the outdoor unit.
For details, see the vacuum pump manual.

Air purging with vacuum pump

Be sure to use a vacuum pump with counter-flow prevention function so that oil inside the pump does not flow back into the air conditioner pipes when the pump stops. (If oil inside the vacuum pump enters into the air conditioner circuit which uses R410A, trouble with the refrigeration system may develop.)

1. Connect the charge hose from the manifold valve to the service port of the gas side packed valve.
2. Connect the charge hose to the port of the vacuum pump.
3. Open fully the low pressure side handle of the gauge manifold valve.
4. Operate the vacuum pump to begin evacuating. Perform evacuating for about 15 minutes if the piping length is 20 meters (15 minutes for 20 meters) (assuming a pump capacity of 27 liters per minute). Confirm that the compound pressure gauge reading is -101 kPa (-76 cmHg).

5. Close the low pressure valve handle of gauge manifold.
6. Open fully the valve stem of the packed valves (both sides of Gas and Liquid).
7. Remove the charging hose from the service port.
8. Securely tighten the caps on the packed valves.

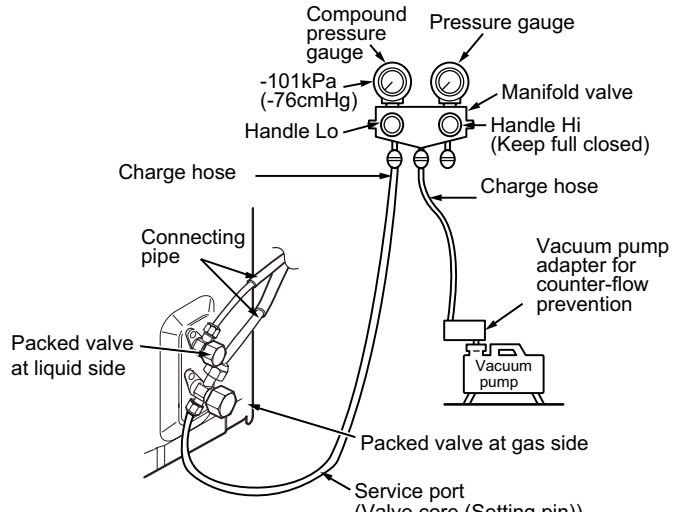

CAUTION

• IMPORTANT POINTS FOR PIPING WORK

1. Keep dust and moisture from entering the pipes.
2. Tighten connections carefully (between pipes and unit).
3. Evacuate the air in the connecting pipes using a VACUUM PUMP.
4. Check for gas leaks at all connections.

Packed Valve handling precautions

- Open the valve stem all the way; but do not try to open it beyond the stopper.
- Securely tighten the valve stem cap with torque in the following table:

Gas side (Ø12 mm)	50 to 55 N·m (5.0 to 5.5 kgf·m)
Liquid side (Ø6 mm)	14 to 18 N·m (1.4 to 1.8 kgf·m)
Service port	14 to 18 N·m (1.4 to 1.8 kgf·m)

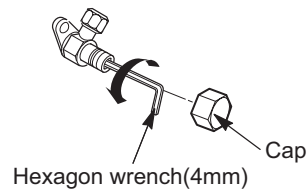

5. Wiring Connection

- 1) Remove the handle from the outdoor unit.
- 2) Fasten the connection cord to the retaining plate using the lock nut.
- 3) Connect connection cord to terminal.
- 4) Install the handle.

The screws are packed with the terminal board.

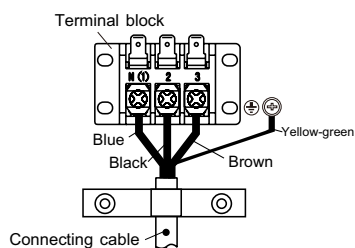

7.5 Power

1. The supply voltage must be the same as the rated voltage of the air conditioner.

2. Prepare a power source for the exclusive use of the air conditioner.

- Incorrect wiring connection may cause electrical parts to burn out.
- Be sure to comply with local regulations/codes when running the wire from outdoor unit to indoor unit. (Size of wire and wiring method etc.)
- Every wire must be securely connected.
- If incorrect or incomplete wiring is carried out, fire or smoke may result.
- Prepare the power supply for the exclusive use of the air conditioner.
- This product can be connected to the main breaker.

Connection to fixed wiring: A switch or circuit breaker that can disconnect all poles must be included in the fixed wiring. Be sure to use an approved circuit breaker or switch. (It's the suggestion value in the table)

Model	Fuse or Circuit Breaker Capacity
18K	25A
24K	

WIRING SYSTEM DIAGRAM

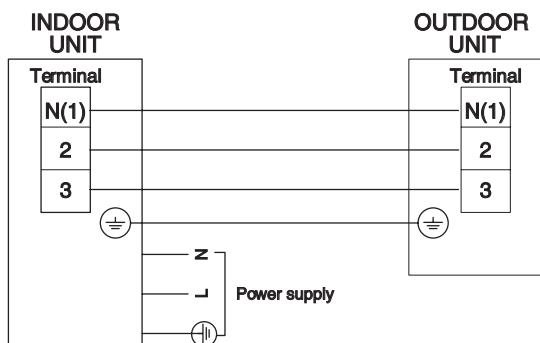

7.6 Test Operation

1. Check that all tubing and wiring have been properly connected.
2. Check that the gas and liquid side service valves are fully open.

1. Gas Leak Test

Check the flare nut connections for gas leaks with a gas leak detector and/or soapy water.

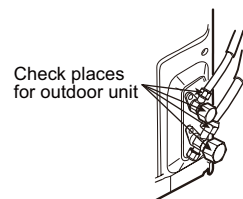
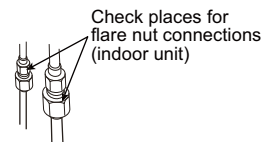

2. Test Running

- 1) Switch on power, press "ON/OFF" button on the wireless remote control to start the operation.
- 2) Press MODE button, to select the COOL, HEAT (Cooling only unit is not available), FAN to check whether the operation is normal or not.

Perform test operation and check items 1 and 2 below.

2.1 INDOOR UNIT

- (1) Is operation of each button on the remote control unit normal?
- (2) Does each lamp light normally?
- (3) Do the air flow-direction louver operate normally?
- (4) Is the drain normal?

2.2 OUTDOOR UNIT

- (1) Is there any abnormal noise and vibration during operation?
- (2) Will noise, wind, or drain water from the unit disturb the neighbors?
- (3) Is there any gas leakage?

8. Exploded Views and Parts List

8.1 Indoor Unit

(1)18K(Without cold plasma)

● Exploded View

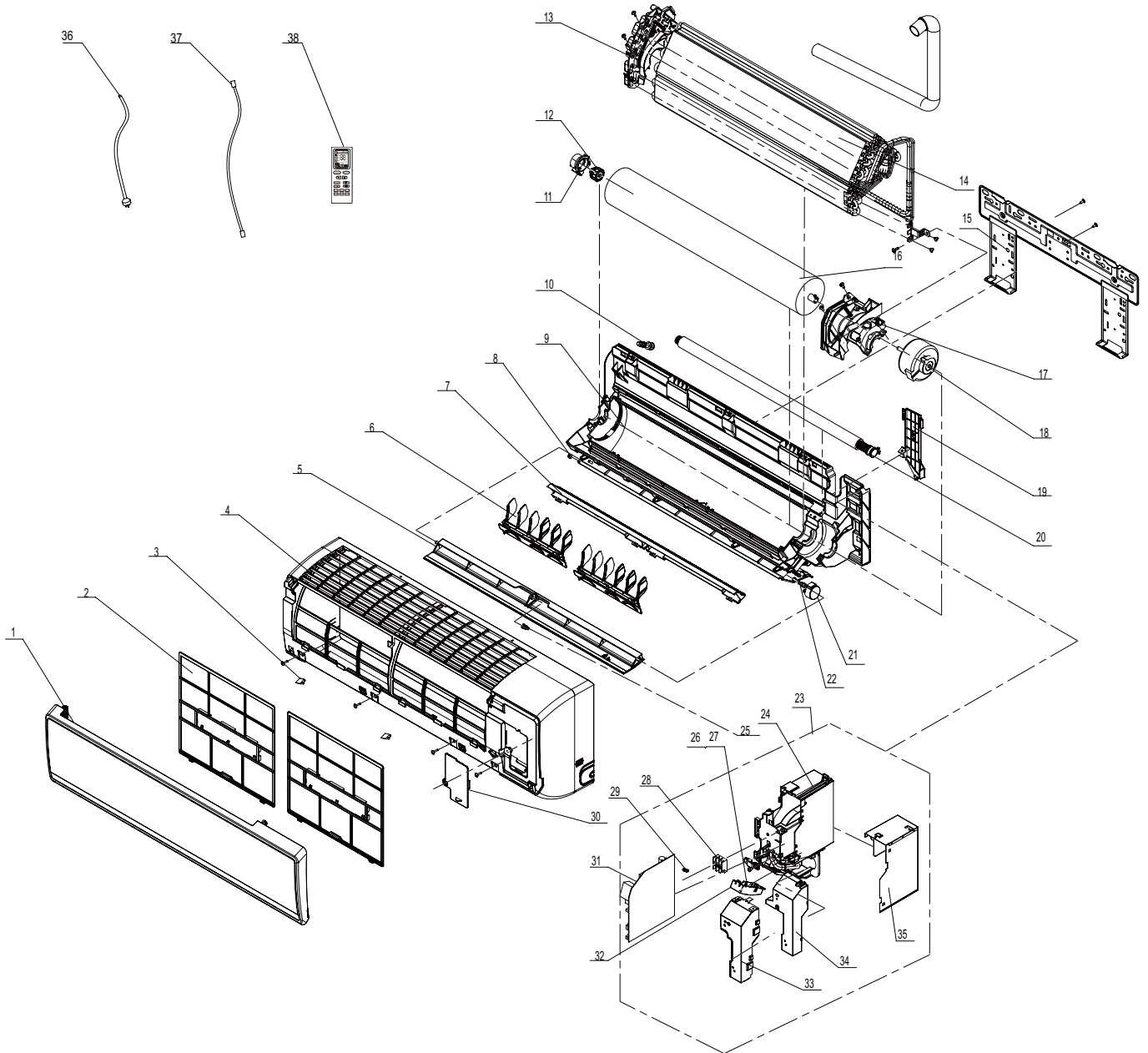

● Parts List

NO.	Description	Part Code			Qty
		CH-S18FTXG	CH-S18FTXG	CH-S18FTXG	
	Product Code	CB146N0090	CB146N0100	CB146N0320	
1	Front Panel Assy	20012496	20012496	20012496	1
2	Filter Sub-Assy	11122104	11122104	11122104	2
3	Screw Cover	242520041	242520041	242520041	1
4	Front Case Assy	20012497	20012497	20012497	1
5	Guide Louver	10512140	10512140	10512140	1
6	Air Louver	10512160	10512160	10512160	2
7	Helicoid tongue	26112232	26112232	26112232	1
8	Left Axile Bush	10512037	10512037	10512037	1
9	Rear Case assy	22202154	22202154	22202154	1
10	Rubber Plug (Water Tray)	76712012	76712012	76712012	1
11	O-Gasket sub-assy of Bearing	76512051	76512051	76512051	1
12	O-Gasket of Cross Fan Bearing	76512203	76512203	76512203	1
13	Evaporator Support	24212119	24212119	24212119	1
14	Evaporator Assy	01002600	01002600	01002603	1
15	Wall Mounting Frame	01252484	01252484	01252484	1
16	Cross Flow Fan	10352036	10352036	10352036	1
17	Motor Press Plate	26112231	26112231	26112231	1
18	Fan Motor	15012116	15012116	15012116	1
19	Pipe Clamp	26112164	26112164	26112164	1
20	Drainage hose	0523001407	0523001407	0523001407	1
21	Step Motor	15012086	15012086	15012086	1
22	Crank	10582070	10582070	10582070	1
23	Electric Box Assy	20202390	20202291	20202404	1
24	Electric Box	20112103	20112103	20112103	1
25	Axile Bush	10542008	10542008	10542008	1
26	Indicator Light Cover	22242084	22242084	22242084	1
27	Indicator shield cover	22242083	22242083	22242083	1
28	Terminal Board	4201026601	4201026601	4201026601	1
29	Jumper	4202300117	4202300117	4202300122	1
30	Electric Box Cover2	20112081	20112081	20112081	1
31	Main Board	30138506	30138505	30138505	1
32	Display Board	30568112	30568112	30568112	1
33	Shield Cover of Electric box Cover	01592088	01592088	01592088	1
34	Electric Box Cover	20122123	20122123	20122123	1
35	Shield cover of Electric Box	01592087	01592087	01592087	1
36	Power Cord	400204873	400204873	400204873	1
37	Connecting Cable	400205382	400205382	400205382	0
38	Remote Controller	30510061	30510061	30510061	1

The data above are subject to change without notice.

Exploded Views and Parts list

NO.	Description	Part Code			Qty
		CH-S18FTXG	CH-S18FTXG	CH-S18FTXG	
	Product Code	CB146N0650	CB146N0270	CB146N0570	
1	Front Panel Assy	20012495S	20012495S	20012495S	1
2	Filter Sub-Assy	11122104	11122104	11122104	2
3	Screw Cover	242520041	242520041	242520041	1
4	Front Case Assy	20012497	20012497	20012497	1
5	Guide Louver	10512140	10512140	10512140	1
6	Air Louver	10512160	10512160	10512160	2
7	Helicoid tongue	26112232	26112232	26112232	1
8	Left Axile Bush	10512037	10512037	10512037	1
9	Rear Case assy	22202154	22202154	22202154	1
10	Rubber Plug (Water Tray)	76712012	76712012	76712012	1
11	O-Gasket sub-assy of Bearing	76512051	76512051	76512051	1
12	O-Gasket of Cross Fan Bearing	76512203	76512203	76512203	1
13	Evaporator Support	24212119	24212119	24212119	1
14	Evaporator Assy	01002600	01002600	01032285	1
15	Wall Mounting Frame	01252484	01252484	01252484	1
16	Cross Flow Fan	10352036	10352036	10352036	1
17	Motor Press Plate	26112231	26112231	26112231	1
18	Fan Motor	15012116	15012116	15012116	1
19	Pipe Clamp	26112164	26112164	26112164	1
20	Drainage hose	0523001407	0523001407	0523001407	1
21	Step Motor	15012086	15012086	15012086	1
22	Crank	10582070	10582070	10582070	1
23	Electric Box Assy	20202390	20202291	20202404	1
24	Electric Box	20112103	20112103	20112103	1
25	Axile Bush	10542008	10542008	10542008	1
26	Indicator Light Cover	22242084	22242084	22242084	1
27	Indicator shield cover	22242083	22242083	22242083	1
28	Terminal Board	4201026601	4201026601	4201026601	1
29	Jumper	4202300117	4202300117	4202300122	1
30	Electric Box Cover2	20112081	20112081	20112081	1
31	Main Board	30138506	30138505	30138505	1
32	Display Board	30568112	30568112	30568112	1
33	Shield Cover of Electric box Cover	01592088	01592088	01592088	1
34	Electric Box Cover	20122123	20122123	20122123	1
35	Shield cover of Electric Box	01592087	01592087	01592087	1
36	Power Cord	400204873	400204873	400204873	1
37	Connecting Cable	400205382	400205382	400205382	0
38	Remote Controller	30510061	30510061	30510061	1

The data above are subject to change without notice.

NO.	Description	Part Code			Qty
		CH-S18FTXG	CH-S18FTXG	CH-S18FTXG	
	Product Code	CB146N09100	CB146N09200	CB146N0580	
1	Front Panel Assy	20012627	20012627	20012627	1
2	Filter Sub-Assy	11122104	11122104	11122104	2
3	Screw Cover	242520041	242520041	242520041	1
4	Front Case Assy	20012497	20012497	20012497	1
5	Guide Louver	10512140	10512140	10512140	1
6	Air Louver	10512160	10512160	10512160	2
7	Helicoid tongue	26112232	26112232	26112232	1
8	Left Axile Bush	10512037	10512037	10512037	1
9	Rear Case assy	22202154	22202154	22202154	1
10	Rubber Plug (Water Tray)	76712012	76712012	76712012	1
11	O-Gasket sub-assy of Bearing	76512051	76512051	76512051	1
12	O-Gasket of Cross Fan Bearing	76512203	76512203	76512203	1
13	Evaporator Support	24212119	24212119	24212119	1
14	Evaporator Assy	01002600	01002600	01002603	1
15	Wall Mounting Frame	01252484	01252484	01252484	1
16	Cross Flow Fan	10352036	10352036	10352036	1
17	Motor Press Plate	26112231	26112231	26112231	1
18	Fan Motor	15012116	15012116	15012116	1
19	Pipe Clamp	26112164	26112164	26112164	1
20	Drainage hose	0523001407	0523001407	0523001407	1
21	Step Motor	15012086	15012086	15012086	1
22	Crank	10582070	10582070	10582070	1
23	Electric Box Assy	20202390	20202291	20202404	1
24	Electric Box	20112103	20112103	20112103	1
25	Axile Bush	10542008	10542008	10542008	1
26	Indicator Light Cover	22242084	22242084	22242084	1
27	Indicator shield cover	22242083	22242083	22242083	1
28	Terminal Board	4201026601	4201026601	4201026601	1
29	Jumper	4202300117	4202300117	4202300122	1
30	Electric Box Cover2	20122142	20122142	20112081	1
31	Main Board	30138506	30138505	30138505	1
32	Display Board	30568112	30568112	30568112	1
33	Shield Cover of Electric box Cover	01592088	01592088	01592088	1
34	Electric Box Cover	20122123	20122123	20122123	1
35	Shield cover of Electric Box	01592087	01592087	01592087	1
36	Power Cord	400204873	400204873	400204873	1
37	Connecting Cable	400205382	400205382	400205382	0
38	Remote Controller	30510061	30510061	30510061	1

The data above are subject to change without notice.

Exploded Views and Parts list

NO.	Description	Part Code		Qty
		CH-S18FTXG	CH-S18FTXG	
		Product Code	Product Code	
1	Front Panel Assy	20012676S	20012872	1
2	Filter Sub-Assy	11122104	11122104	2
3	Screw Cover	242520041	242520041	1
4	Front Case Assy	20012497	20012873	1
5	Guide Louver	10512140	10512140	1
6	Air Louver	10512160	10512160	2
7	Helicoid tongue	26112232	26112232	1
8	Left Axile Bush	10512037	10512037	1
9	Rear Case assy	22202154	22202154	1
10	Rubber Plug (Water Tray)	76712012	76712012	1
11	O-Gasket sub-assy of Bearing	76512051	76512051	1
12	O-Gasket of Cross Fan Bearing	76512203	76512203	1
13	Evaporator Support	24212119	24212119	1
14	Evaporator Assy	01002603	01002603	1
15	Wall Mounting Frame	01252484	01252484	1
16	Cross Flow Fan	10352036	10352036	1
17	Motor Press Plate	26112231	26112231	1
18	Fan Motor	15012116	15012116	1
19	Pipe Clamp	26112164	26112164	1
20	Drainage hose	0523001407	0523001407	1
21	Step Motor	15012086	15012086	1
22	Crank	10582070	10582070	1
23	Electric Box Assy	20202404	20202404	1
24	Electric Box	20112103	20112103	1
25	Axile Bush	10542008	10542008	1
26	Indicator Light Cover	22242084	22242084	1
27	Indicator shield cover	22242083	22242083	1
28	Terminal Board	4201026601	4201026601	1
29	Jumper	4202300122	4202300122	1
30	Electric Box Cover2	20122142	20122142	1
31	Main Board	30138505	30138505	1
32	Display Board	30568112	30568112	1
33	Shield Cover of Electric box Cover	01592088	01592088	1
34	Electric Box Cover	20122123	20122123	1
35	Shield cover of Electric Box	01592087	01592087	1
36	Power Cord	400204873	400204873	1
37	Connecting Cable	400205382	400205382	0
38	Remote Controller	30510061	30510061	1

The data above are subject to change without notice.

NO.	Description	Part Code		Qty
		CH-S18FTXG	CH-S18FTXG	
	Product code	CB146N0780	CB146N0781	
1	Front Panel Assy	20012731S	20012731S	1
2	Filter Sub-Assy	11122104	11122104	2
3	Screw Cover	242520041	242520041	1
4	Front Case Assy	20012497	20012497	1
5	Guide Louver	10512140	10512140	1
6	Air Louver	10512160	10512160	2
7	Helicoid tongue	26112232	26112232	1
8	Left Axile Bush	10512037	10512037	1
9	Rear Case assy	22202154	22202154	1
10	Rubber Plug (Water Tray)	76712012	76712012	1
11	O-Gasket sub-assy of Bearing	76512051	76512051	1
12	O-Gasket of Cross Fan Bearing	76512203	76512203	1
13	Evaporator Support	24212119	24212119	1
14	Evaporator Assy	01002315	01002315	1
15	Wall Mounting Frame	01252484	01252484	1
16	Cross Flow Fan	10352036	10352036	1
17	Motor Press Plate	26112231	26112231	1
18	Fan Motor	15012116	15012116	1
19	Pipe Clamp	2611216402	2611216402	1
20	Drainage hose	0523001407	0523001407	1
21	Step Motor	15012086	15012086	1
22	Crank	10582070	10582070	1
23	Electric Box Assy	20202404	20202404	1
24	Electric Box	20112103	20112103	1
25	Axile Bush	10542008	10542008	1
26	Indicator Light Cover	22242084	22242084	1
27	Indicator shield cover	22242083	22242083	1
28	Terminal Board	4201026601	4201026601	1
29	Jumper	4202300122	4202300122	1
30	Electric Box Cover2	20122142	20122142	1
31	Main Board	30138505	30138505	1
32	Display Board	30568112	30568112	1
33	Shield Cover of Electric box Cover	01592088	01592088	1
34	Electric Box Cover	20122123	20122123	1
35	Shield cover of Electric Box	01592087	01592087	1
36	Power Cord	400204873	400204873	1
37	Connecting Cable	400205382	400205382	0
38	Remote Controller	30510061	30510061	1

The data above are subject to change without notice.

(2) 18K (Cold plasma)

● Exploded View

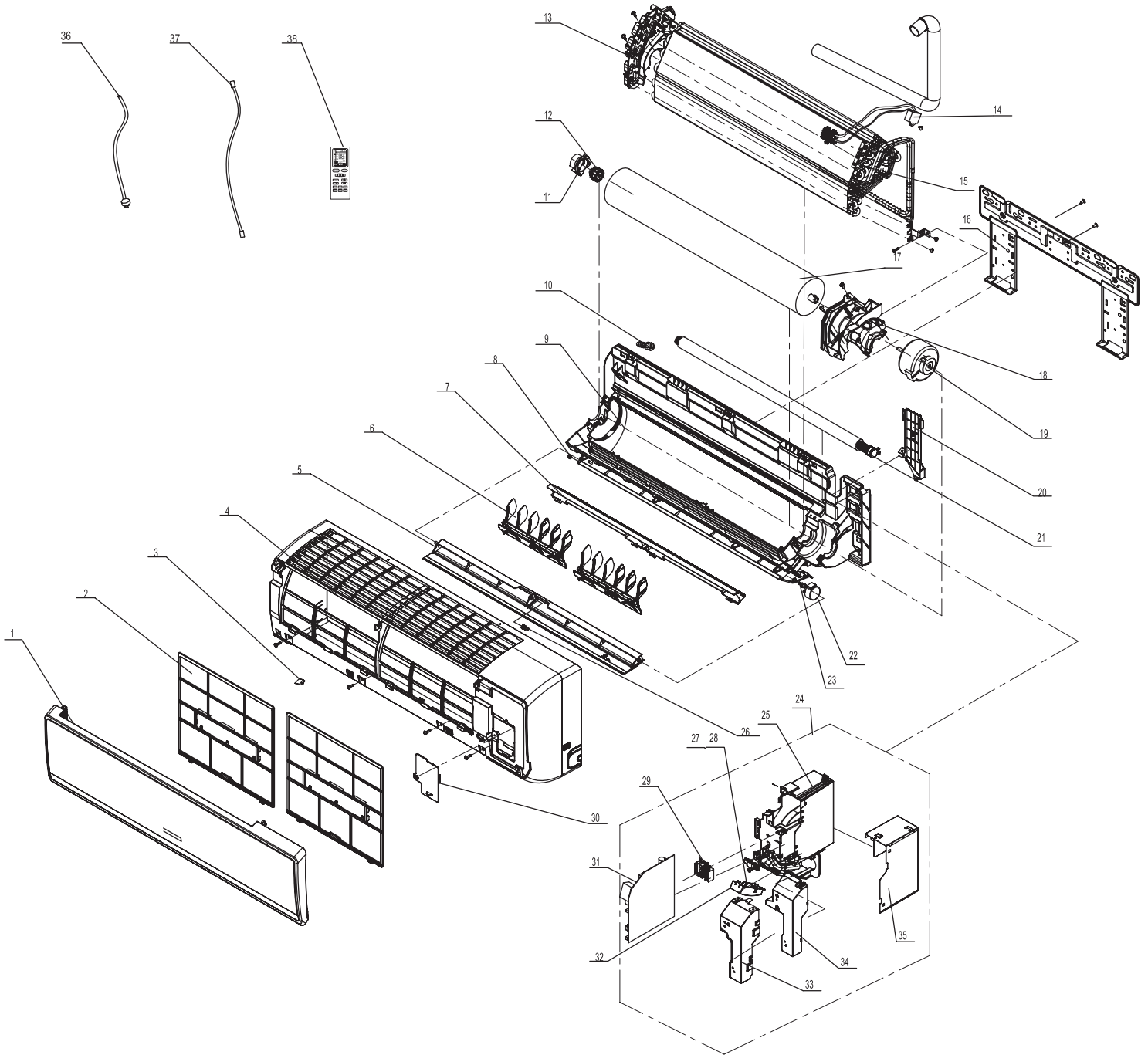

● Parts List

NO.	Description	Part Code			Qty
		CH-S18FTXG	CH-S18FTXG	CH-S18FTXG	
	Product Code	CB146N0102	CB146N0271	CB146N0681	
1	Front Panel	20012496	20012495S	20012676S	1
2	Filter Sub-Assy	11122104	11122104	11122104	2
3	Screw Cover	242520041	242520041	242520041	1
4	Front Case Assy	20012497	20012497	20012497	1
5	Guide Louver	10512140	10512140	10512140	1
6	Air Louver	10512160	10512160	10512160	2
7	Helicoid tongue	26112232	26112232	26112232	1
8	Left Axile Bush	10512037	10512037	10512037	1
9	Rear Case assy	22202154	22202154	22202154	1
10	Rubber Plug (Water Tray)	76712012	76712012	76712012	1
11	Ring of Bearing	26152022	26152022	26152022	1
12	O-Gasket sub-assy of Bearing	76512051	76512051	76512051	1
13	Evaporator Support	24212119	24212119	24212119	1
14	Cold Plasma Generator Sub-assy	1114000901	1114000901	1114000901	1
15	Evaporator Assy	01002600	01002600	01002603	1
16	Wall Mounting Frame	01252484	01252484	01252484	1
17	Cross Flow Fan	10352036	10352036	10352036	1
18	Motor Press Plate	26112231	26112231	26112231	1
19	Fan Motor	15012116	15012116	15012116	1
20	Pipe Clamp	26112164	26112164	26112164	1
21	Drainage hose	0523001407	0523001407	0523001407	1
22	Step Motor	15012086	15012086	15012086	1
23	Crank	10582070	10582070	10582070	1
24	Electric Box Assy	20202822	20202822	20202820	1
25	Electric Box	20112103	20112103	20112103	1
26	Axile Bush	10542008	10542008	10542008	1
27	Indicator Light Cover	22242084	22242084	22242084	1
28	Indicator shield cover	22242083	22242083	22242083	1
29	Terminal Board	4201026601	4201026601	4201026601	1
30	Electric Box Cover2	20122142	20122142	20122142	1
31	Main Board	30138507	30138507	30138507	1
32	Display Board	30568112	30568112	30568112	1
33	Shield Cover of Electric box Cover	01592088	01592088	01592088	1
34	Electric Box Cover	20122123	20122123	20122123	1
35	Shield cover of Electric Box	01592087	01592087	01592087	1
36	Power Cord	400204873	400204873	400204873	1
37	Connecting Cable	400205382	400205382	400205382	0
38	Remote Controller	30510061	30510061	30510061	1

The data above are subject to change without notice.

(3) 24K

● Exploded View

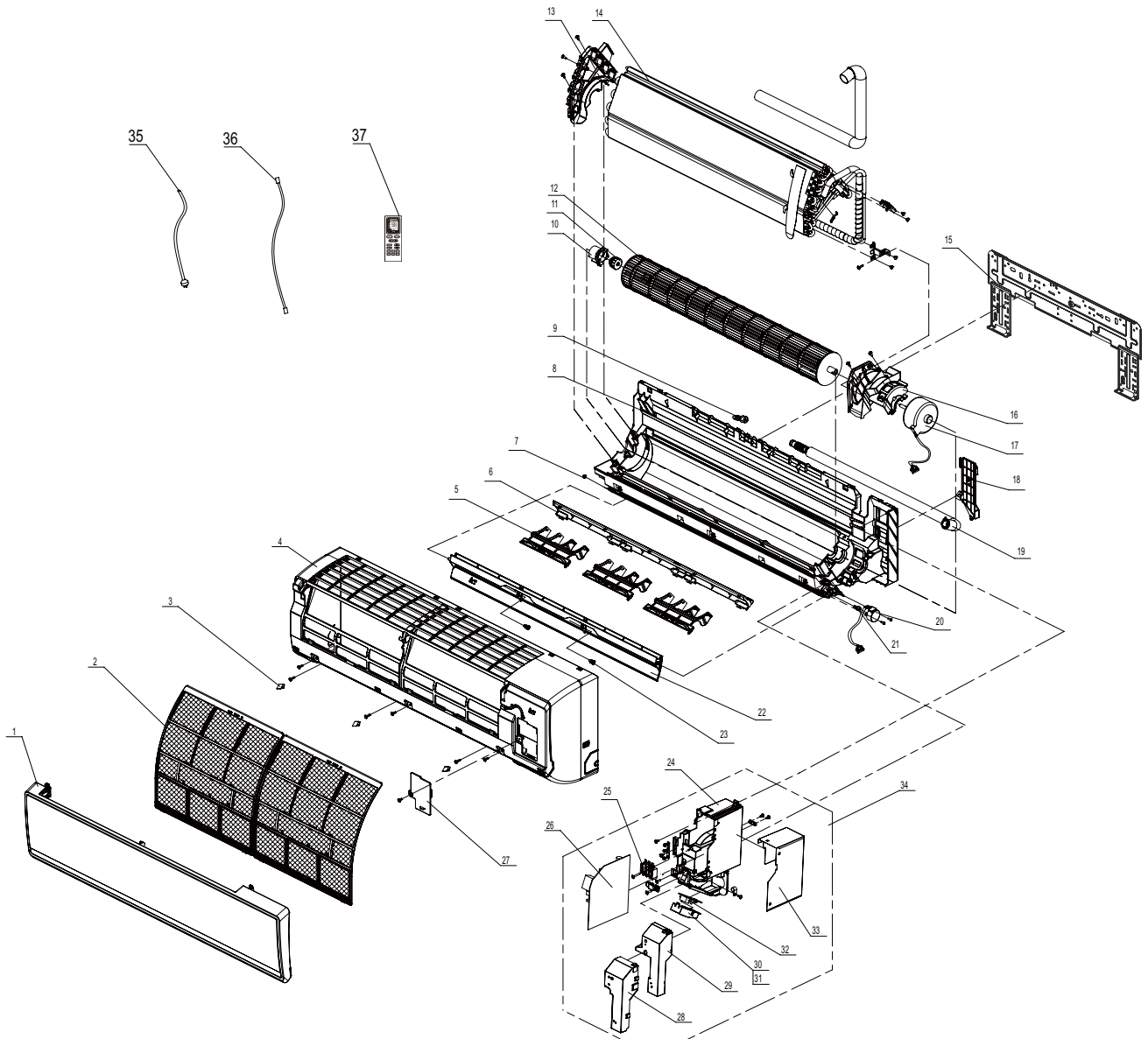

● Parts List

NO.	Description	Part Code			Qty
		CH-S24FTXG	CH-S24FTXG	CH-S24FTXG	
	Product Code	CB146N0150	CB146N0160	CB146N0210	
1	Front Panel Assy	20012513	20012513	20012513	1
2	Filter Sub-Assy	11122091	11122091	11122091	2
3	Screw Cover	24252016	24252016	24252016	3
4	Front Case Assy	20012514	20012514	20012514	1
5	Air Louver	10512139	10512139	10512139	3
6	Helicoid tongue	26112229	26112229	26112229	1
7	Left Axile Bush	10512037	10512037	10512037	1
8	Rear Case assy	22202157	22202157	22202157	1
9	Rubber Plug (Water Tray)	76712012	76712012	76712012	1
10	Ring of Bearing	26152025	26152025	26152025	1
11	O-Gasket of Cross Fan Bearing	76512203	76512203	76512203	1
12	Cross Flow Fan	10352030	10352030	10352030	1
13	Evaporator Support	24212103	24212103	24212103	1
14	Evaporator Assy	01002269	01002269	01002269	1
15	Wall Mounting Frame	01252004	01252004	01252004	1
16	Motor Press Plate	26112184	26112184	26112184	1
17	Fan Motor	15012098	15012098	15012098	1
18	Pipe Clamp	26112188	26112188	26112188	1
19	Drainage hose	0523001405	0523001405	0523001405	1
20	Step Motor	1521300101	1521300101	1521300101	1
21	Crank	10582070	10582070	10582070	1
22	Guide Louver	10512138	10512138	10512138	1
23	Axile Bush	10542008	10542008	10542008	2
24	Electric Box	20112103	20112103	20112103	1
25	Terminal Board	4201026601	4201026601	4201026601	1
26	Main Board	30138514	30138513	30138513	1
27	Electric Box Cover2	20112081	20112081	20112081	1
28	Shield Cover of Electric box Cover	01592088	01592088	01592088	1
29	Electric Box Cover	20122123	20122123	20122123	1
30	Indicator shield cover	22242083	22242083	22242083	1
31	Indicator Light Cover	22242084	22242084	22242084	1
32	Display Board	30568112	30568112	30568112	1
33	Shield cover of Electric Box	01592087	01592087	01592087	1
34	Electric Box Assy	2020230201	20202302	2020230204	1
35	Power Cord	400203253	400203253	400203253	1
36	Connecting Cable	400205382	400205382	400205382	0
37	Remote Controller	30510061	30510061	30510061	1

The data above are subject to change without notice.

Exploded Views and Parts list

NO.	Description	Part Code			Qty
		CH-S24FTXG	CH-S24FTXG	CH-S24FTXG	
	Product Code	CB146N0640	CB146N0260	CB146N0600	
1	Front Panel Assy	20012502S	20012502S	20012502S	1
2	Filter Sub-Assy	11122091	11122091	11122091	2
3	Screw Cover	24252016	24252016	24252016	3
4	Front Case Assy	20012514	20012514	20012514	1
5	Air Louver	10512139	10512139	10512139	3
6	Helicoid tongue	26112229	26112229	26112229	1
7	Left Axile Bush	10512037	10512037	10512037	1
8	Rear Case assy	22202157	22202157	22202157	1
9	Rubber Plug (Water Tray)	76712012	76712012	76712012	1
10	Ring of Bearing	26152025	26152025	26152025	1
11	O-Gasket of Cross Fan Bearing	76512203	76512203	76512203	1
12	Cross Flow Fan	10352030	10352030	10352030	1
13	Evaporator Support	24212103	24212103	24212103	1
14	Evaporator Assy	01002269	01002269	01002269	1
15	Wall Mounting Frame	01252004	01252004	01252004	1
16	Motor Press Plate	26112184	26112184	26112184	1
17	Fan Motor	15012098	15012098	15012098	1
18	Pipe Clamp	26112188	26112188	26112188	1
19	Drainage hose	0523001405	0523001405	0523001405	1
20	Step Motor	1521300101	1521300101	1521300101	1
21	Crank	10582070	10582070	10582070	1
22	Guide Louver	10512138	10512138	10512138	1
23	Axile Bush	10542008	10542008	10542008	2
24	Electric Box	20112103	20112103	20112103	1
25	Terminal Board	4201026601	4201026601	4201026601	1
26	Main Board	30138514	30138513	30138513	1
27	Electric Box Cover2	20112081	20112081	20112081	1
28	Shield Cover of Electric box Cover	01592088	01592088	01592088	1
29	Electric Box Cover	20122123	20122123	20122123	1
30	Indicator shield cover	22242083	22242083	22242083	1
31	Indicator Light Cover	22242084	22242084	22242084	1
32	Display Board	30568112	30568112	30568112	1
33	Shield cover of Electric Box	01592087	01592087	01592087	1
34	Electric Box Assy	2020230201	20202302	2020230204	1
35	Power Cord	400203253	400203253	400203253	1
36	Connecting Cable	400205382	400205382	400205382	0
37	Remote Controller	30510061	30510061	30510061	1

The data above are subject to change without notice.

NO.	Description	Part Code			Qty
		CH-S24FTXG	CH-S24FTXG	CH-S24FTXG	
	Product Code	CB146N08900	CB146N09000	CB146N0590	
1	Front Panel Assy	20012692	20012692	2001251301	1
2	Filter Sub-Assy	11122091	11122091	11122091	2
3	Screw Cover	24252016	24252016	24252016	3
4	Front Case Assy	20012514	20012514	20012514	1
5	Air Louver	10512139	10512139	10512139	3
6	Helicoid tongue	26112229	26112229	26112229	1
7	Left Axile Bush	10512037	10512037	10512037	1
8	Rear Case assy	22202157	22202157	22202157	1
9	Rubber Plug (Water Tray)	76712012	76712012	76712012	1
10	Ring of Bearing	26152025	26152025	26152025	1
11	O-Gasket of Cross Fan Bearing	76512203	76512203	76512203	1
12	Cross Flow Fan	10352030	10352030	10352030	1
13	Evaporator Support	24212103	24212103	24212103	1
14	Evaporator Assy	01002269	01002269	01002269	1
15	Wall Mounting Frame	01252004	01252004	01252004	1
16	Motor Press Plate	26112184	26112184	26112184	1
17	Fan Motor	15012098	15012098	15012098	1
18	Pipe Clamp	26112188	26112188	26112188	1
19	Drainage hose	0523001405	0523001405	0523001405	1
20	Step Motor	1521300101	1521300101	1521300101	1
21	Crank	10582070	10582070	10582070	1
22	Guide Louver	10512138	10512138	10512138	1
23	Axile Bush	10542008	10542008	10542008	2
24	Electric Box	20112103	20112103	20112103	1
25	Terminal Board	4201026601	4201026601	4201026601	1
26	Main Board	30138514	30138513	30138513	1
27	Electric Box Cover2	20112081	20112081	20112081	1
28	Shield Cover of Electric box Cover	01592088	01592088	01592088	1
29	Electric Box Cover	20122123	20122123	20122123	1
30	Indicator shield cover	22242083	22242083	22242083	1
31	Indicator Light Cover	22242084	22242084	22242084	1
32	Display Board	30568112	30568112	30568112	1
33	Shield cover of Electric Box	01592087	01592087	01592087	1
34	Electric Box Assy	2020230201	20202302	2020230204	1
35	Power Cord	400203253	400203253	400203253	1
36	Connecting Cable	400205382	400205382	400205382	0
37	Remote Controller	30510061	30510061	30510061	1

The data above are subject to change without notice.

Exploded Views and Parts list

NO.	Description	Part Code		Qty
		CH-S24FTXG	CH-S24FTXG	
		Product Code	Product Code	
		CB146N0730	CB146N09700	
1	Front Panel Assy	20012659S	20012828	1
2	Filter Sub-Assy	11122091	11122091	2
3	Screw Cover	24252016	24252016	3
4	Front Case Assy	20012514	20012845	1
5	Air Louver	10512139	10512139	3
6	Helicoid tongue	26112229	26112229	1
7	Left Axile Bush	10512037	10512037	1
8	Rear Case assy	22202157	22202157	1
9	Rubber Plug (Water Tray)	76712012	76712012	1
10	Ring of Bearing	26152025	26152025	1
11	O-Gasket of Cross Fan Bearing	76512203	76512203	1
12	Cross Flow Fan	10352030	10352030	1
13	Evaporator Support	24212103	24212103	1
14	Evaporator Assy	01002269	01002269	1
15	Wall Mounting Frame	01252004	01252004	1
16	Motor Press Plate	26112184	26112184	1
17	Fan Motor	15012098	15012098	1
18	Pipe Clamp	26112188	26112188	1
19	Drainage hose	523001405	0523001405	1
20	Step Motor	1521300101	1521300101	1
21	Crank	10582070	10582070	1
22	Guide Louver	10512138	10512138	1
23	Axile Bush	10542008	10542008	2
24	Electric Box	20112103	20112103	1
25	Terminal Board	4201026601	4201026601	1
26	Main Board	30138513	30138513	1
27	Electric Box Cover2	20112081	20112081	1
28	Shield Cover of Electric box Cover	1592088	01592088	1
29	Electric Box Cover	20122123	20122123	1
30	Indicator shield cover	22242083	22242083	1
31	Indicator Light Cover	22242084	22242084	1
32	Display Board	30568112	30568112	1
33	Shield cover of Electric Box	1592087	01592087	1
34	Electric Box Assy	2020230204	2020230204	1
35	Power Cord	400203253	400203253	1
36	Connecting Cable	400205382	400205382	0
37	Remote Controller	30510061	30510061	1

The data above are subject to change without notice.

NO.	Description	Part Code		Qty
		CH-S24FTXG	CH-S24FTXG	
		Product code	Product code	
		CB146N11900	CB146N11901	
1	Front Panel Case	20012739	20012739P	1
2	Filter Sub-Assy	11122091	11122091	2
3	Screw Cover	24252016	24252016	3
4	Front Case Assy	20012514	20012514	1
5	Air Louver	10512139	10512139	3
6	Helicoid Tongue	26112229	26112229	1
7	Left Axile Bush	10512037	10512037	1
8	Rear Case assy	22202157	22202157	1
9	Rubber Plug (Water Tray)	76712012	76712012	1
10	Ring of Bearing	26152025	26152025	1
11	O-Gasket of Cross Fan Bearing	76512203	76512203	1
12	Cross Flow Fan	10352030	10352030	1
13	Evaporator Support	24212103	24212103	1
14	Evaporator Assy	1002269	1002269	1
15	Wall Mounting Frame	1252004	1252004	1
16	Motor Press Plate	26112184	26112184	1
17	Fan Motor	15012098	15012098	1
18	Pipe Clamp	26112188	26112188	1
19	Drainage Hose	523001405	523001405	1
20	Step Motor	1521300101	1521300101	1
21	Crank	10582070	10582070	1
22	Guide Louver	10512138	10512138	1
23	Axile Bush	10542008	10542008	2
24	Electric Box	20112103	20112103	1
25	Terminal Board	4201026601	4201026601	1
26	Main Board	30138513	30138513	1
27	Electric Box Cover2	20112081	20112081	1
28	Shield Cover of Electric Box	1592087	1592087	1
29	Electric Box Cover	20122123	20122123	1
30	Indicator Shield Cover	22242083	22242083	1
31	Indicator Light Cover	22242084	22242084	1
32	Display Board	30568112	30568112	1
33	Shield Cover of Electric Box Cover	1592088	1592088	1
34	Electric Box Assy	2020230204	2020230204	1
35	Power Cord	400203253	400203253	1
36	Connecting Cable	400205382	400205382	0
37	Remote Controller	305100611	305100611	1

The data above are subject to change without notice.

8.2 Outdoor Unit

(1) 18K COOL

● Exploded View

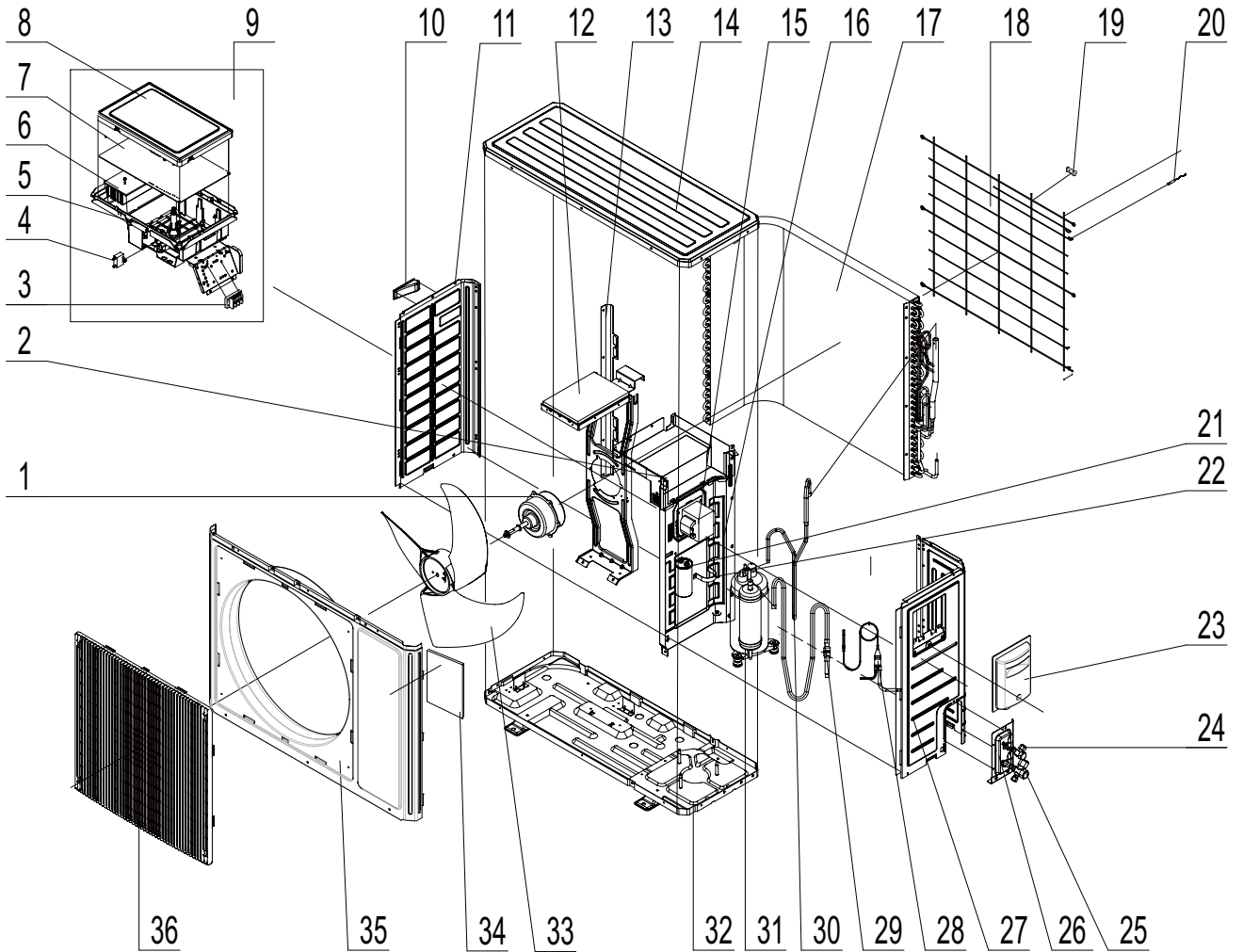

● Parts List

NO.	Description	Part Code		Qty
		CH-S18FTXG		
		Product Code	CB146W0090	
1	Fan Motor	1501506301	1	
2	Electric box (fireproofing)	01413148	1	
3	Terminal Board	42011113	1	
4	Capacitor CBB61	33010010	1	
5	Electric Box	20113008	1	
6	Radiator	49010252	1	
7	Main Board	30138385	1	
8	Electric Box Cover Sub-Assy	02603217	1	
9	Electric Box Assy	02603331	1	
10	left handle	26235401	1	
11	Left Side Plate	01305041P	1	
12	Motor Support Sub-Assy	0170502004	1	
13	Supporting board(condenser)	01173132		
14	Top Cover	01255005P	1	
15	Reactor	43130021	1	
16	Clapboard Sub-Assy	01232902	1	
17	Condenser Assy	01113590	1	
18	Rear Grill	01473043	1	
19	Wiring clamp	26115004	1	
20	Temperature Sensor	3900030901	1	
21	Capacitor CBB65	33000065	1	
22	Capacitor Clamp sub-assy	01413098	1	
23	Handle	26235254	1	
24	Cut-off valve Sub-Assy	07133204	1	
25	Cut-off valve Sub-Assy	07133060	1	
26	Valve support assy	01715010P	1	
27	Right Side Plate	01305053P	1	
28	Capillary Sub-Assy	03063132	1	
29	Inhalation Tube Sub-Assy	03733084	1	
30	Discharge tube 2	03713610	1	
31	Compressor and fittings	00103501	1	
32	Chassis Sub-assy	01203714P	1	
33	Axial Flow Fan	10335008	1	
34	Insulated board (cover of electric box)	20113003	1	
35	Front Panel	01535008P	1	
36	Front grill	22415002	1	

The data above are subject to change without notice.

(2) 18K HEAT PUMP

● Exploded View

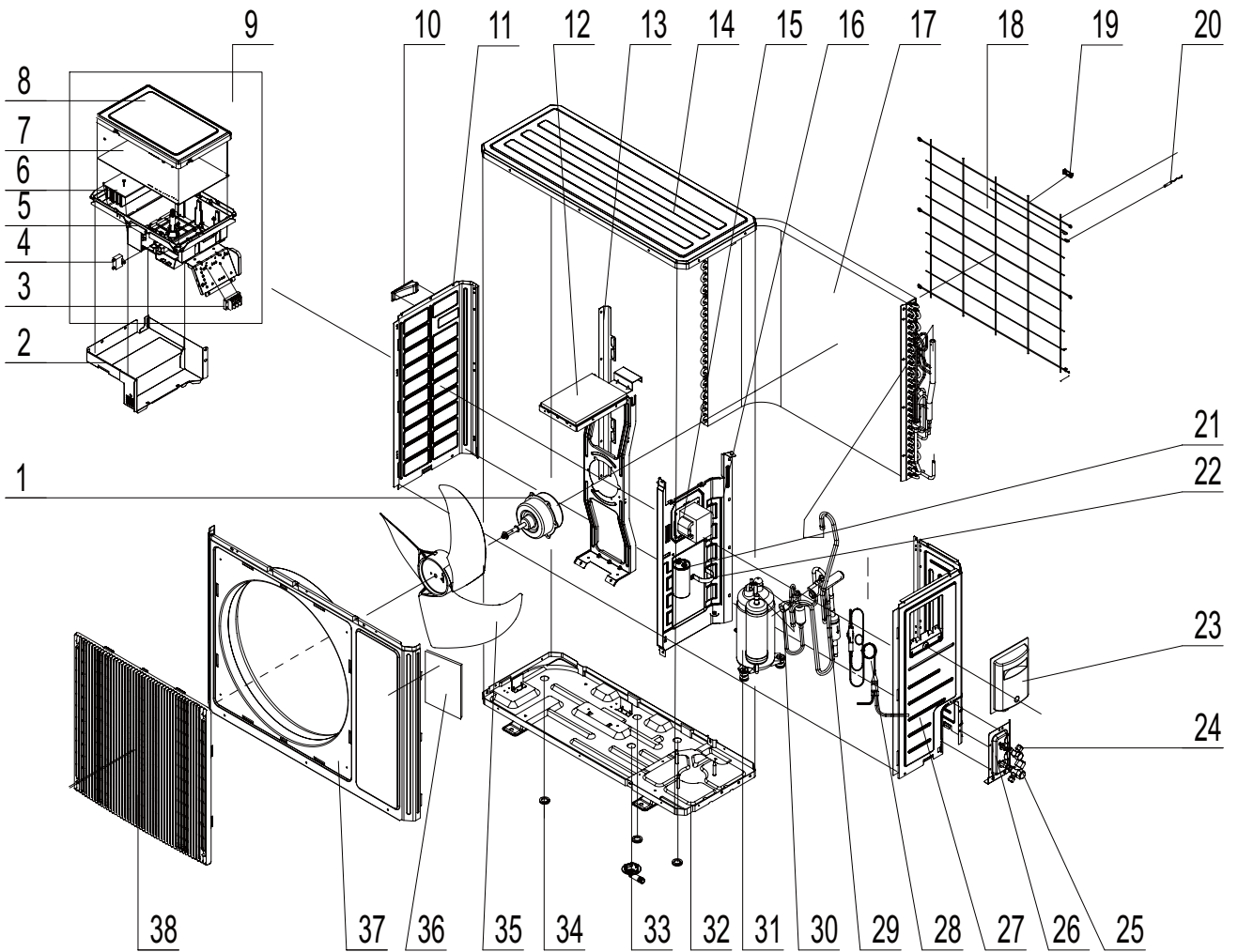

● Parts List

NO.	Description	Part Code		Qty
		CH-S18FTXG	CH-S18FTXG	
	Product Code	CB146W0100	CB146W0320	
1	Fan Motor	1501506301	1501506301	1
2	Electric box (fireproofing)	01413148	01413148	1
3	Terminal Board	42011113	42011113	1
4	Capacitor CBB61	33010010	33010010	1
5	Electric Box	20113008	20113008	1
6	Radiator	49010252	49010252	1
7	Main Board	30138333	30138568	1
8	Electric Box Cover Sub-Assy	02603217	02603217	1
9	Electric Box Assy	02603272	02603337	1
10	left handle	26235401	26235401	1
11	Left Side Plate	01305041P	01305041P	1
12	Motor Support Sub-Assy	01705020	01705020	1
13	Supporting board(condenser)	01795010	01795010	1
14	Top Cover	01255005P	01255005P	1
15	Reactor	43130021	43130021	1
16	Clapboard Sub-Assy	01232902	01232902	1
17	Condenser Assy	01113530	01113635	1
18	Rear Grill	01473043	01473043	1
19	Wiring clamp	26115004	26115004	1
20	Temperature Sensor	3900030901	3900030901	1
21	Capacitor CBB65	33000065	33000065	1
22	Capacitor Clamp sub-assy	01413098	01413098	1
23	Handle	26235254	26235254	1
24	Cut-off valve Sub-Assy	07133204	07133204	1
25	Cut-off valve Sub-Assy	07133060	07133060	1
26	Valve support assy	01715010P	01715010P	1
27	Right Side Plate	01305053P	01305053P	1
28	Capillary Sub-Assy	03063077	03063168	1
29	4-way Valve Assy	0312324501	0312324501	1
30	Magnet Coil	4300040033	4300040033	1
31	Compressor and fittings	00103501	00103501	1
32	Chassis Sub-assy	0120371401P	0120371401P	1
33	Drainage Connector	06123401	06123401	1
34	Drainage Plug	06813401	06813401	3
35	Axial Flow Fan	10335008	10335008	1
36	Insulated board (cover of electric box)	20113003	20113003	1
37	Front Panel	01535008P	01535008P	1
38	Front grill	22415002	22415002	1

The data above are subject to change without notice.

(3) 24K COOL

● Exploded View

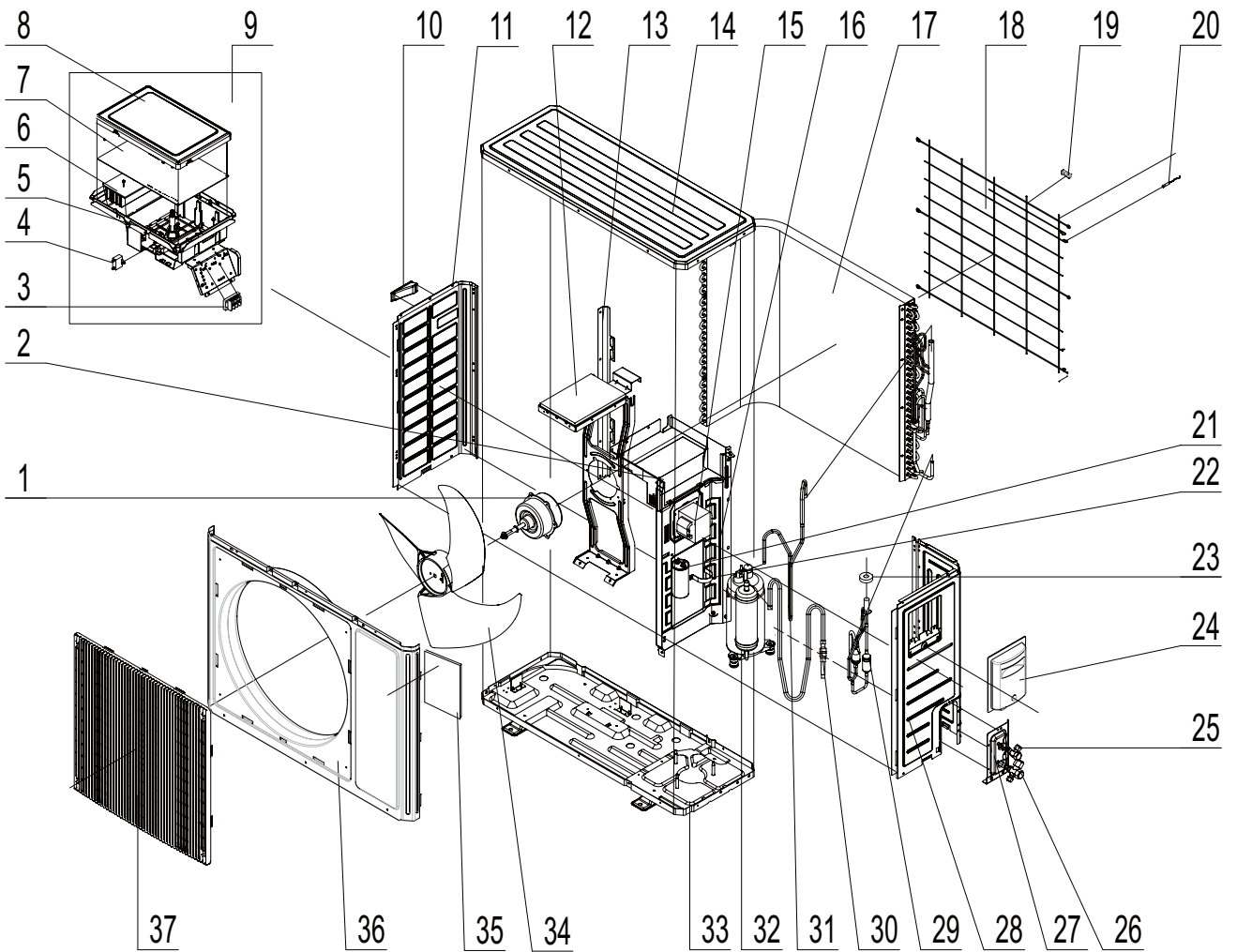

● Parts List

NO.	Description	Part Code	Qty
		CH-S24FTXG	
	Product Code	CB146W0150	
1	Fan Motor	1501506301	1
2	Electric box (fireproofing)	01413148	1
3	Terminal Board	42011113	1
4	Capacitor CBB61	33010010	1
5	Electric Box	20113008	1
6	Radiator	49010008	1
7	Main Board	30138386	1
8	Electric Box Cover Sub-Assy	02603217	1
9	Electric Box Assy	0260306618	1
10	left handle	26235401	1
11	Left Side Plate	01305041P	1
12	Motor Support Sub-Assy	01705020	1
13	Supporting board(condenser)	01795010	1
14	Top Cover	01255005P	1
15	Reactor	43130021	1
16	Clapboard Sub-Assy	01232902	1
17	Condenser Assy	0111338601	1
18	Rear Grill	01473043	1
19	Wiring clamp	26115004	1
20	Temperature Sensor	3900030901	1
21	Capacitor CBB65	33000065	1
22	Capacitor Clamp sub-assy	01413098	1
23	Electric expand valve fitting	4300876704	1
24	Handle	26235254	1
25	Cut-off valve Sub-Assy	07133184	1
26	Cut-off valve Sub-Assy	07133060	1
27	Valve support assy	01715010P	1
28	Right Side Plate	01305053P	1
29	Electronic Expansion Valve	07133183	1
30	Inhalation Tube Sub-Assy	03733084	1
31	Discharge Tube Sub-Assy	03733083	1
32	Compressor and fittings	00103501	1
33	Chassis Sub-assy	0120371401P	1
34	Axial Flow Fan	10335008	1
35	Insulated board (cover of electric box)	20113003	1
36	Front Panel	01535008P	1
37	Front grill	22415002	1

The data above are subject to change without notice.

(4) 24K HEAT PUMP

● Exploded View

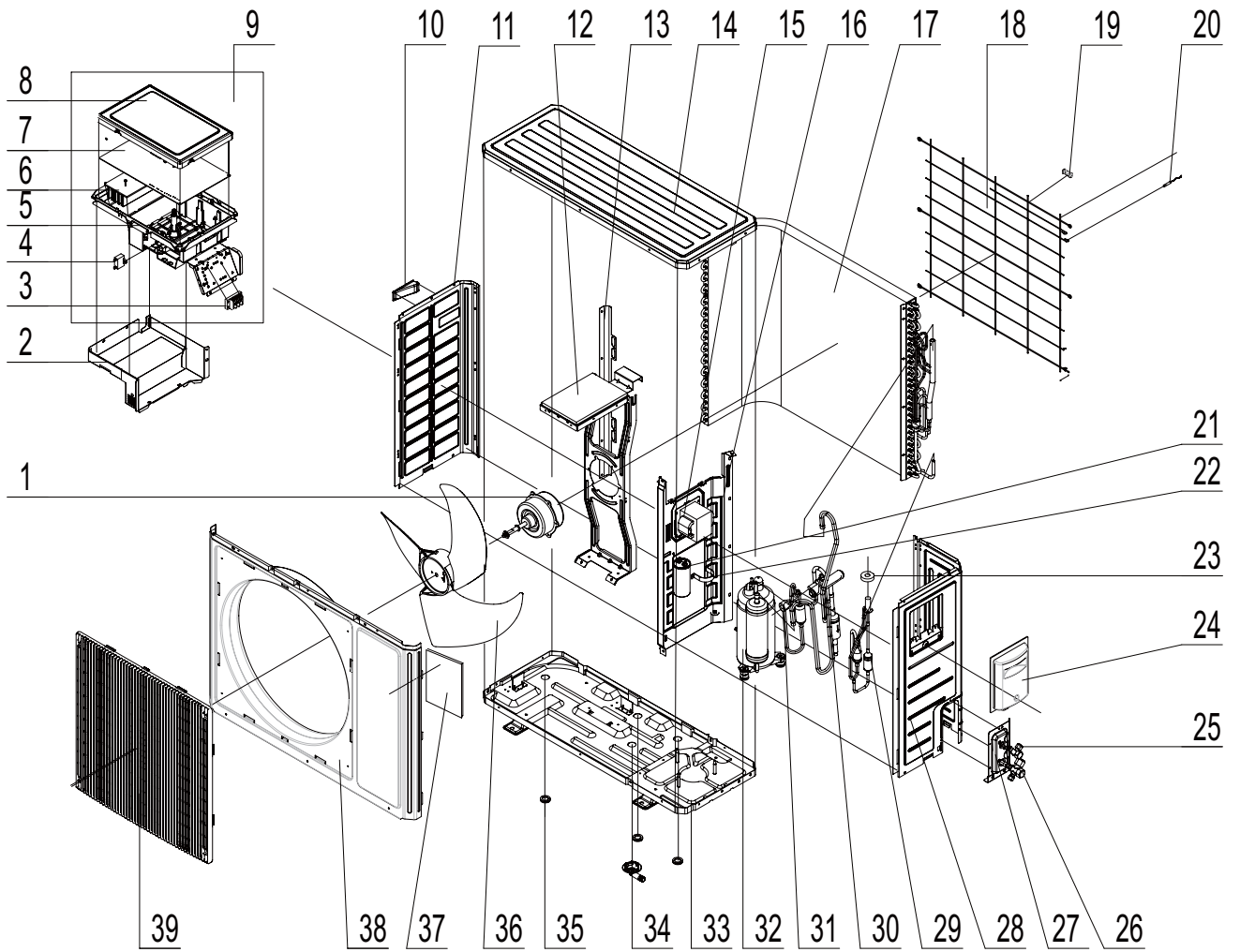

● Parts List

NO.	Description	Part Code		Qty
		CH-S24FTXG	CH-S24FTXG	
	Product Code	CB146W0160	CB146W0210	
1	Fan Motor	1501506301	1501506301	1
2	Electric box (fireproofing)	01413148	01413148	1
3	Terminal Board	42011113	42011113	1
4	Capacitor CBB61	33010010	33010010	1
5	Electric Box	20113008	20113008	1
6	Radiator	49010008	49010008	1
7	Main Board	30138334	30138569	1
8	Electric Box Cover Sub-Assy	02603217	02603217	1
9	Electric Box Assy	0260306619	0260306625	1
10	left handle	26235401	26235401	1
11	Left Side Plate	01305041P	01305041P	1
12	Motor Support Sub-Assy	01705020	0170512001	1
13	Supporting board(condenser)	01795010	01173415	1
14	Top Cover	01255005P	01255005P	1
15	Reactor	43130021	43130021	1
16	Clapboard Sub-Assy	01232902	01232902	1
17	Condenser Assy	01113386	01113609	1
18	Rear Grill	01473043	01473043	1
19	Wiring clamp	26115004	26115004	1
20	Temperature Sensor	3900030901	3900030901	1
21	Capacitor CBB65	33000065	33000065	1
22	Capacitor Clamp sub-assy	01413098	01413098	1
23	Electric expand valve fitting	4300876704	4300876704	1
24	Handle	26235254	26235254	1
25	Cut-off valve Sub-Assy	07133058	07133058	1
26	Cut-off valve Sub-Assy	07133060	07133060	1
27	Valve support assy	01715010P	01715010P	1
28	Right Side Plate	01305053P	01305053P	1
29	Electronic Expansion Valve	07133556	07133206	1
30	4-way Valve Assy	03123245	03123360	1
31	Magnet Coil	4300040033	4300040033	1
32	Compressor and fittings	00103501	00103501	1
33	Chassis Sub-assy	0120371401P	0120371402P	1
34	Drainage Connector	06123401	06123401	1
35	Drainage Plug	06813401	06813401	3
36	Axial Flow Fan	10335008	10335008	1
37	Insulated board (cover of electric box)	20113003	20113003	1
38	Front Panel	01535008P	01535008P	1
39	Front grill	22415002	22415002	1

The data above are subject to change without notice.

9. Troubleshooting

9.1 Precautions before Performing Inspection or Repair

Be cautious during installation and maintenance. Do operation following the regulations to avoid electric shock and casualty or even death due to drop from high attitude.

* Static maintenance is the maintenance during de-energization of the air conditioner.

For static maintenance, make sure that the unit is de-energized and the plug is disconnected.

*dynamic maintenance is the maintenance during energization of the unit.

Before dynamic maintenance, check the electricity and ensure that there is ground wire on the site. Check if there is electricity on the housing and connection copper pipe of the air conditioner with voltage tester. After ensure insulation place and the safety, the maintenance can be performed.

Take sufficient care to avoid directly touching any of the circuit parts without first turning off the power.

At times such as when the circuit board is to be replaced, place the circuit board assembly in a vertical position.

Normally,diagnose troubles according to the trouble diagnosis procedure as described below.(Refer to the check points in servicing written on the wiring diagrams attached to the indoor/outdoor units.)

No.	Troubleshooting procedure
1	Confirmation
2	Judgement by Flashing LED of Indoor/Outdoor Unit
3	How to Check simply the main part

NOTE:

A large-capacity electrolytic capacitor is used in the outdoor unit controller(inverter).Therefore,if the power supply is turned off,charge(charging voltage DC280V to 380V)remains and discharging takes a lot of time.. After turning off the power source,if touching the charging section before discharging, an electrical shock may be caused. Discharge the electrolytic capacitor completely by using soldering iron,etc.

<Discharging method>

(1)remove the inverter cover(Outdoor Unit)

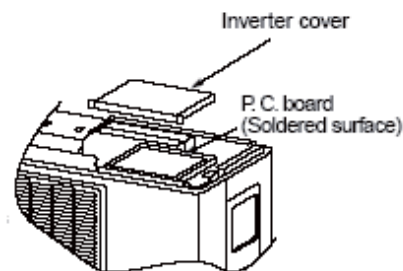

(2)As shown below,connect the discharge resistance (approx.100 Ω , 20W)or plug of the soldering iron to voltage between + - terminals of the electrolytic capacitor (test 3 “D” and “E” point) on PC Board for 30s, and then perform discharging

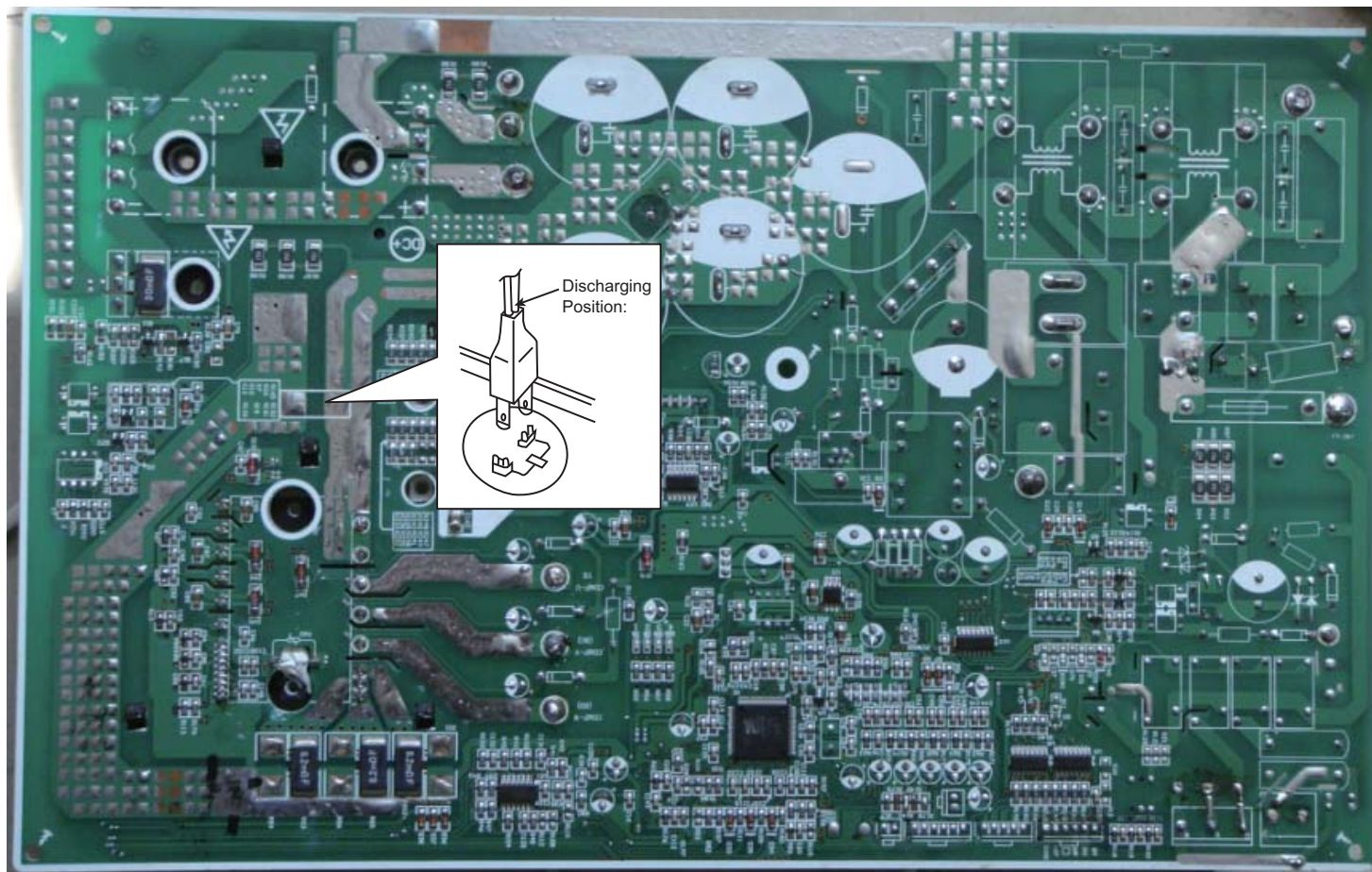

9.2 Confirmation

(1)Confirmation of Power Supply

Confirm that the power breaker operates(ON) normally;

(2)Confirmation of Power Voltage

Confirm that power voltage is AC 220-230-240 \pm 10%. If power voltage is not in this range, the unit may not operate normally.

9.3 Flashing LED of Indoor/Outdoor Unit and Primary Judgement

Troubleshooting

No.	Malfunction Name	Display Method of Indoor Unit			Display Method of Outdoor Unit (Indicator has 3 kinds of display status and they will be displayed circularly every 5s.)				A/C status	Possible Causes	
		Dual-8 Code Display	Indicator Display (during blinking, ON 0.5s and OFF 0.5s)			<input type="checkbox"/> OFF <input checked="" type="checkbox"/> Illuminated <input checked="" type="checkbox"/> Blink					
			Operation Indicator	Cool Indicator	Heating Indicator	D5 (D40)	D6 (D41)	D16 (D42)			D30 (D43)
1	High pressure protection of system	E1	OFF 3s and blink once			<input type="checkbox"/>	<input checked="" type="checkbox"/>	<input checked="" type="checkbox"/>	<input checked="" type="checkbox"/>	During cooling and drying operation, except indoor fan operates, all loads stop operation. During heating operation, the complete unit stops.	Possible reasons: 1. Refrigerant was superabundant; 2. Poor heat exchange (including filth blockage of heat exchanger and bad radiating environment); Ambient temperature is too high.
2	Antifreezing protection	E2	OFF 3S and blink twice			<input checked="" type="checkbox"/>	<input type="checkbox"/>	<input checked="" type="checkbox"/>	<input type="checkbox"/>	During cooling and drying operation, compressor and outdoor fan stop while indoor fan operates.	1. Poor air-return in indoor unit; 2. Fan speed is abnormal; 3. Evaporator is dirty.
3	High discharge temperature protection of compressor	E4	OFF 3S and blink 4 times			<input checked="" type="checkbox"/>	<input type="checkbox"/>	<input checked="" type="checkbox"/>	<input checked="" type="checkbox"/>	During cooling and drying operation, compressor and outdoor fan stop while indoor fan operates. During heating operation, all loads stop.	Please refer to the malfunction analysis (discharge protection, overload).
4	Overcurrent protection	E5	OFF 3S and blink 5 times			<input type="checkbox"/>	<input checked="" type="checkbox"/>	<input checked="" type="checkbox"/>	<input type="checkbox"/>	During cooling and drying operation, compressor and outdoor fan stop while indoor fan operates. During heating operation, all loads stop.	1. Supply voltage is unstable; 2. Supply voltage is too low and load is too high; 3. Evaporator is dirty.
5	Communication Malfunction	E6	OFF 3S and blink 6 times			<input type="checkbox"/>	<input type="checkbox"/>	<input type="checkbox"/>	<input checked="" type="checkbox"/>	During cooling operation, compressor stops while indoor fan motor operates. During heating operation, the complete unit stops.	Refer to the corresponding malfunction analysis.
6	High temperature resistant protection	E8	OFF 3S and blink 8 times			<input checked="" type="checkbox"/>	<input type="checkbox"/>	<input checked="" type="checkbox"/>	<input checked="" type="checkbox"/>	During cooling operation: compressor will stop while indoor fan will operate. During heating operation, the complete unit stops.	Refer to the malfunction analysis (overload, high temperature resistant).
7	Circuit PG motor (indoor fan) has circuit malfunction by zero cross detection	U8	OFF 3S and blink for 17 times							Operation of remote controller or control panel is available, but the unit wont act.	Control board is damaged.
8	PG motor (indoor fan motor) does not operate	H6	OFF 3S and blink 11 times							The complete unit will stop operation.	Poor connection for PGF in circuit diagram; Malfunction of indoor units control panel AP1; Malfunction of indoor units motor M1.
9	Malfunction protection of jumper cap	C5	OFF 3S and blink 15 times							The complete unit will stop operation.	Poor connection for the jumper cap on indoor units control panel AP1; please reinsert or replace the jumper cap;
10	Indoor ambient temperature sensor is open/short circuited	F1		OFF 3S and blink once						During cooling and drying operation, indoor unit operates while other loads will stop; during heating operation, the complete unit will stop operation.	1.Room temperature sensor hasn't been connected well with indoor units control panel AP1 (refer to the wiring diagram for indoor unit); 2.Room temperature sensor is damaged (please refer to the resistance table of temperature sensor)

No.	Malfunction Name	Display Method of Indoor Unit				Display Method of Outdoor Unit (Indicator has 3 kinds of display status and they will be displayed circularly every 5s.)				A/C status	Possible Causes
		Dual-8 Code Display	Indicator Display (during blinking, ON 0.5s and OFF 0.5s)			<input type="checkbox"/> OFF <input checked="" type="checkbox"/> Illuminated <input checked="" type="checkbox"/> Blink					
			Operation Indicator	Cool Indicator	Heating Indicator	D5 (D40)	D6 (D41)	D16 (D42)	D30 (D43)		
11	Indoor evaporator temperature sensor is open/short circuited	F2		OFF 3S and blink twice					During cooling and drying operation, indoor unit will operate while other loads will stop; During heating operation, the complete unit will stop operation.	1.Room temperature sensor hasnt been connected well with indoor units control panel AP1 (refer to the wiring diagram for indoor unit); 2.Room temperature sensor is damaged (please refer to the resistance table of temperature sensor)	
12	Outdoor ambient temperature sensor is open/short circuited	F3		OFF 3S and blink 3 times	<input type="checkbox"/>	<input type="checkbox"/>	<input checked="" type="checkbox"/>	<input checked="" type="checkbox"/>	During cooling and drying operating, compressor stops while indoor fan operates; During heating operation, the complete unit will stop operation	Outdoor temperature sensor hasnt been connected well or is damaged. Please check it by referring to the resistance table for temperature sensor)	
13	Outdoor condenser temperature sensor is open/short circuited	F4		OFF 3S and blink 4 times	<input type="checkbox"/>	<input type="checkbox"/>	<input checked="" type="checkbox"/>	<input type="checkbox"/>	During cooling and drying operation, compressor stops while indoor fan will operate; During heating operation, the complete unit will stop operation.	Outdoor temperature sensor hasnt been connected well or is damaged. Please check it by referring to the resistance table for temperature sensor)	
14	Outdoor discharge temperature sensor is open/short circuited	F5		OFF 3S and blink 5 times	<input type="checkbox"/>	<input type="checkbox"/>	<input checked="" type="checkbox"/>	<input checked="" type="checkbox"/>	During cooling and drying operation, compressor will sop after operating for about 3 mins, while indoor fan will operate; During heating operation, the complete unit will stop after operating for about 3 mins.	1.Outdoor temperature sensor hasnt been connected well or is damaged. Please check it by referring to the resistance table for temperature sensor) 2.The head of temperature sensor hasnt been inserted into the copper tube	
15	Limit/ decrease frequency due to overload	F6		OFF 3S and blink for 6 times	<input checked="" type="checkbox"/>	<input type="checkbox"/>	<input checked="" type="checkbox"/>	<input checked="" type="checkbox"/>	All loads operate normally, while operation frequency for compressor is decreased	Refer to the malfunction analysis (overload, high temperature resistant)	
16	Decrease frequency due to overcurrent	F8		OFF 3S and blink 8 times	<input checked="" type="checkbox"/>	<input checked="" type="checkbox"/>	<input type="checkbox"/>	<input checked="" type="checkbox"/>	All loads operate normally, while operation frequency for compressor is decreased	The input supply voltage is too low; System pressure is too high and overload	
17	Decrease frequency due to high air discharge	F9		OFF 3S and blink 9 times	<input checked="" type="checkbox"/>	<input checked="" type="checkbox"/>	<input type="checkbox"/>	<input type="checkbox"/>	All loads operate normally, while operation frequency for compressor is decreased	Overload or temperature is too high; Refrigerant is insufficient; Malfunction of electric expansion valve (EKV)	
18	Voltage for DC bus-bar is too high	PH		OFF 3S and blink 11 times	<input type="checkbox"/>	<input checked="" type="checkbox"/>	<input type="checkbox"/>	<input checked="" type="checkbox"/>	During cooling and drying operation, compressor will stop while indoor fan will operate; During heating operation, the complete unit will stop operation.	1. Measure the voltage of position L and N on wiring board (XT), if the voltage is higher than 265VAC, turn on the unit after the supply voltage is increased to the normal range. 2.If the AC input is normal, measure the voltage of electrolytic capacitor C on control panel (AP1), if its normal, theres malfunction for the circuit, please replace the control panel (AP1)	
19	Malfunction of complete units current detection	U5		OFF 3S and blink 13 times	<input type="checkbox"/>	<input checked="" type="checkbox"/>	<input checked="" type="checkbox"/>	<input checked="" type="checkbox"/>	During cooling and drying operation, the compressor will stop while indoor fan will operate; During heating operating, the complete unit will stop operation.	Theres circuit malfunction on outdoor units control panel AP1, please replace the outdoor units control panel AP1.	
20	Overcurrent protection of phase current for compressor	P5		OFF 3S and blink 15 times	<input type="checkbox"/>	<input checked="" type="checkbox"/>	<input type="checkbox"/>	<input type="checkbox"/>	During cooling and drying operation, compressor will stop while indoor fan will operate; During heating operation, the complete unit will stop operation.	Refer to the malfunction analysis (IPM protection, loss of synchronism protection and overcurrent protection of phase current for compressor.	

Troubleshooting

No.	Malfunction Name	Display Method of Indoor Unit			Display Method of Outdoor Unit (Indicator has 3 kinds of display status and they will be displayed circularly every 5s.)				A/C status	Possible Causes	
		Dual-8 Code Display	Indicator Display (during blinking, ON 0.5s and OFF 0.5s)			<input type="checkbox"/> OFF <input checked="" type="checkbox"/> Illuminated <input checked="" type="checkbox"/> Blink					
			Operation Indicator	Cool Indicator	Heating Indicator	D5 (D40)	D6 (D41)	D16 (D42)			D30 (D43)
21	Defrosting	H1			OFF 3S and blink once					Defrosting will occur in heating mode. Compressor will operate while indoor fan will stop operation.	Its the normal state
22	Static dedusting protection	H2			OFF 3S and blink twice						/
23	Overload protection for compressor	H3			OFF 3S and blink 3 times	<input type="checkbox"/>	<input checked="" type="checkbox"/>	<input checked="" type="checkbox"/>	<input type="checkbox"/>	During cooling and drying operation, compressor will stop while indoor fan will operate; During heating operation, the complete unit will stop operation.	1. Wiring terminal OVC-COMP is loosened. In normal state, the resistance for this terminal should be less than 1ohm. 2.Refer to the malfunction analysis (discharge protection, overload)
24	System is abnormal	H4			OFF 3S and blink 4 times	<input checked="" type="checkbox"/>	<input type="checkbox"/>	<input checked="" type="checkbox"/>	<input checked="" type="checkbox"/>	During cooling and drying operation, compressor will stop while indoor fan will operate; During heating operation, the complete unit will stop operation.	Refer to the malfunction analysis (overload, high temperature resistant)
25	IPM protection	H5			OFF 3S and blink 5 times	<input type="checkbox"/>	<input checked="" type="checkbox"/>	<input type="checkbox"/>	<input checked="" type="checkbox"/>	During cooling and drying operation, compressor will stop while indoor fan will operate; During heating operation, the complete unit will stop operation.	Refer to the malfunction analysis (IPM protection, loss of synchronism protection and overcurrent protection of phase current for compressor.
26	PFC protection	HC			OFF 3S and blink 6 times	<input type="checkbox"/>	<input checked="" type="checkbox"/>	<input checked="" type="checkbox"/>	<input checked="" type="checkbox"/>	During cooling and drying operation, compressor will stop while indoor fan will operate; During heating operation, the complete unit will stop operation.	Refer to the malfunction analysis
27	Desynchronizing of compressor	H7			OFF 3S and blink 7 times	<input type="checkbox"/>	<input checked="" type="checkbox"/>	<input checked="" type="checkbox"/>	<input checked="" type="checkbox"/>	During cooling and drying operation, compressor will stop while indoor fan will operate; During heating operation, the complete unit will stop operation.	Refer to the malfunction analysis (IPM protection, loss of synchronism protection and overcurrent protection of phase current for compressor.
28	Decrease frequency due to high temperature resistant during heating operation	H0			OFF 3S and blink 10 times	<input checked="" type="checkbox"/>	<input type="checkbox"/>	<input checked="" type="checkbox"/>	<input checked="" type="checkbox"/>	All loads operate normally, while operation frequency for compressor is decreased	Refer to the malfunction analysis (overload, high temperature resistant)
29	Failure start-up	LC			OFF 3S and blink 11 times	<input type="checkbox"/>	<input checked="" type="checkbox"/>	<input type="checkbox"/>	<input checked="" type="checkbox"/>	During cooling and drying operation, compressor will stop while indoor fan will operate; During heating operation, the complete unit will stop operation.	Refer to the malfunction analysis
30	Malfunction of phase current detection circuit for compressor	U1			OFF 3S and blink 13 times	<input type="checkbox"/>	<input checked="" type="checkbox"/>	<input checked="" type="checkbox"/>	<input type="checkbox"/>	During cooling and drying operation, compressor will stop while indoor fan will operate; During heating operation, the complete unit will stop	Replace outdoor control panel AP1

No.	Malfunction Name	Display Method of Indoor Unit				Display Method of Outdoor Unit (Indicator has 3 kinds of display status and they will be displayed circularly every 5s.)				A/C status	Possible Causes
		Dual-8 Code Display	Indicator Display (during blinking, ON 0.5s and OFF 0.5s)			<input type="checkbox"/> OFF <input checked="" type="checkbox"/> Illuminated <input checked="" type="checkbox"/> Blink					
			Operation Indicator	Cool Indicator	Heating Indicator	D5 (D40)	D6 (D41)	D16 (D42)	D30 (D43)		
31	EEPROM malfunction	EE			OFF 3S and blink 15 times	<input type="checkbox"/>	<input type="checkbox"/>	<input type="checkbox"/>	<input checked="" type="checkbox"/>	During cooling and drying operation, compressor will stop while indoor fan will operate; During heating operation, the complete unit will stop	Replace outdoor control panel AP1
32	Charging malfunction of capacitor	PU			OFF 3S and blink 17 times	<input type="checkbox"/>	<input checked="" type="checkbox"/>	<input type="checkbox"/>	<input checked="" type="checkbox"/>	During cooling and drying operation, compressor will stop while indoor fan will operate; During heating operation, the complete unit will stop	Refer to the part three—charging malfunction analysis of capacitor
33	Malfunction of module temperature sensor circuit	P7			OFF 3S and blink 18 times	<input type="checkbox"/>	<input type="checkbox"/>	<input checked="" type="checkbox"/>	<input checked="" type="checkbox"/>	During cooling and drying operation, compressor will stop while indoor fan will operate; During heating operation, the complete unit will stop	Replace outdoor control panel AP1
34	Module high temperature protection	P8			OFF 3S and blink 19 times	<input checked="" type="checkbox"/>	<input type="checkbox"/>	<input checked="" type="checkbox"/>	<input checked="" type="checkbox"/>	During cooling operation, compressor will stop while indoor fan will operate; During heating operation, the complete unit will stop	After the complete unit is de-energized for 20mins, check whether the thermal grease on IPM Module of outdoor control panel AP1 is sufficient and whether the radiator is inserted tightly. If its no use, please replace control panel AP1.
35	Malfunction of voltage dropping for DC bus-bar	U3			OFF 3S and blink 20 times	<input type="checkbox"/>	<input checked="" type="checkbox"/>	<input checked="" type="checkbox"/>	<input checked="" type="checkbox"/>	During cooling and drying operation, compressor will stop while indoor fan will operate; During heating operation, the complete unit will stop	Supply voltage is unstable
36	Voltage of DC bus-bar is too low	PL			OFF 3S and blink 21 times	<input type="checkbox"/>	<input checked="" type="checkbox"/>	<input checked="" type="checkbox"/>	<input type="checkbox"/>	During cooling and drying operation, compressor will stop while indoor fan will operate; During heating operation, the complete unit will stop	1. Measure the voltage of position L and N on wiring board (XT), if the voltage is higher than 150VAC, turn on the unit after the supply voltage is increased to the normal range. 2.If the AC input is normal, measure the voltage of electrolytic capacitor C on control panel (AP1), if its normal, theres malfunction for the circuit, please replace the control panel (AP1)
37	Limit/decrease frequency due to high temperature of module	EU				<input checked="" type="checkbox"/>	<input checked="" type="checkbox"/>	<input checked="" type="checkbox"/>	<input checked="" type="checkbox"/>	All loads operate normally, while operation frequency for compressor is decreased	Discharging after the complete unit is de-energized for 20mins, check whether the thermal grease on IPM Module of outdoor control panel AP1 is sufficient and whether the radiator is inserted tightly. If its no use, please replace control panel AP1.
38	The four-way valve is abnormal	U7				<input checked="" type="checkbox"/>	<input type="checkbox"/>	<input checked="" type="checkbox"/>	<input type="checkbox"/>	If this malfunction occurs during heating operation, the complete unit will stop operation.	1.Supply voltage is lower than AC175V; 2.Wiring terminal 4V is loosened or broken; 3.4V is damaged, please replace 4V.
39	Zero-crossing malfunction of outdoor unit	U9				<input checked="" type="checkbox"/>	<input checked="" type="checkbox"/>	<input checked="" type="checkbox"/>	<input type="checkbox"/>	During cooling operation, compressor will stop while indoor fan will operate; during heating,the complete unit will stop operation.	Replace outdoor control panel AP1
40	Limit/decrease frequency due to antifreezing	FH				<input checked="" type="checkbox"/>	<input checked="" type="checkbox"/>	<input checked="" type="checkbox"/>	<input type="checkbox"/>	All loads operate normally, while operation frequency for compressor is decreased	Poor air-return in indoor unit or fan speed is too low

9.4 How to Check simply the main part

4.1 Indoor unit:

(1)Temperature sensor malfunction

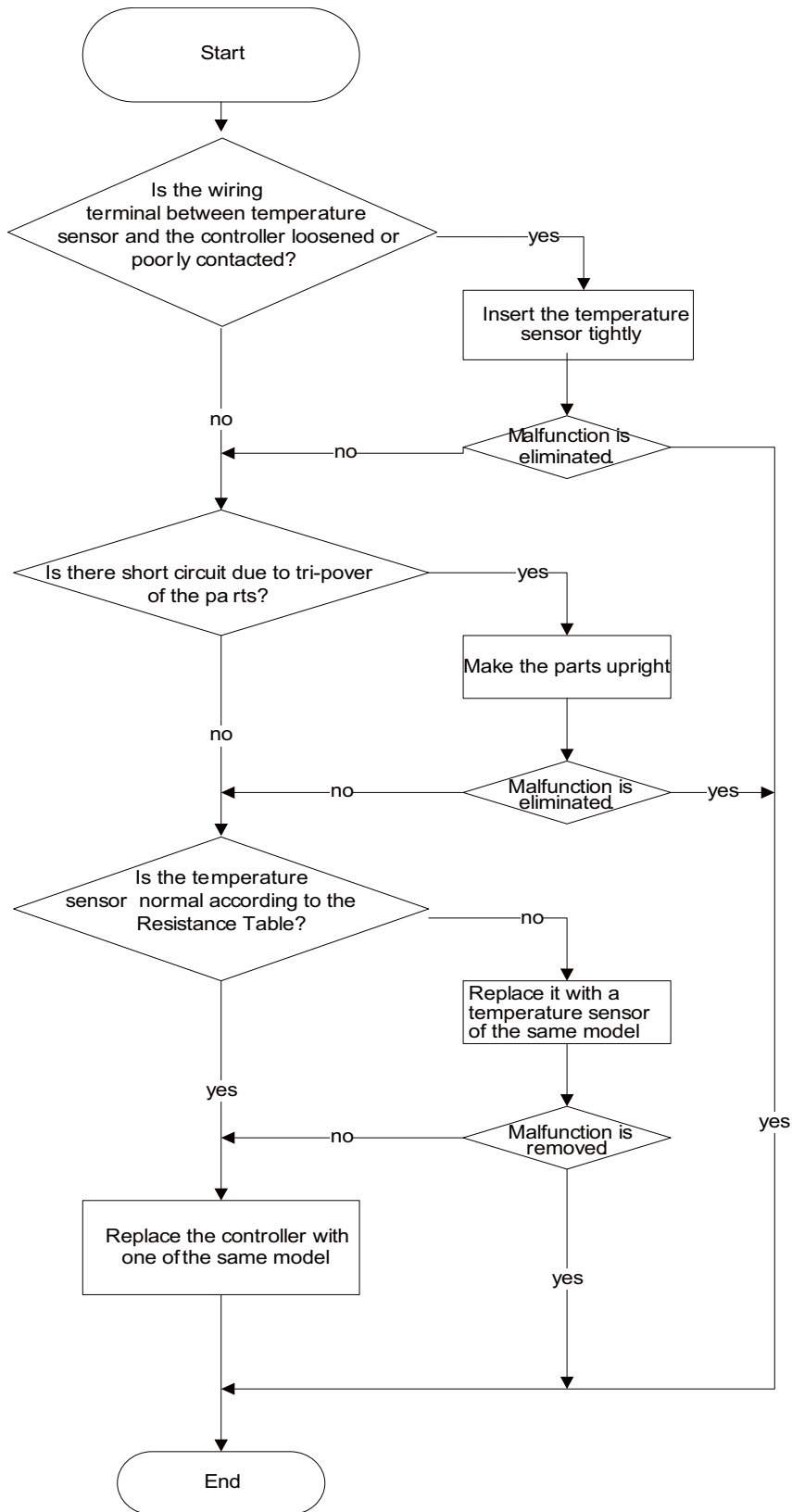

(2)PG motor (indoor fan) does not operate (H6)

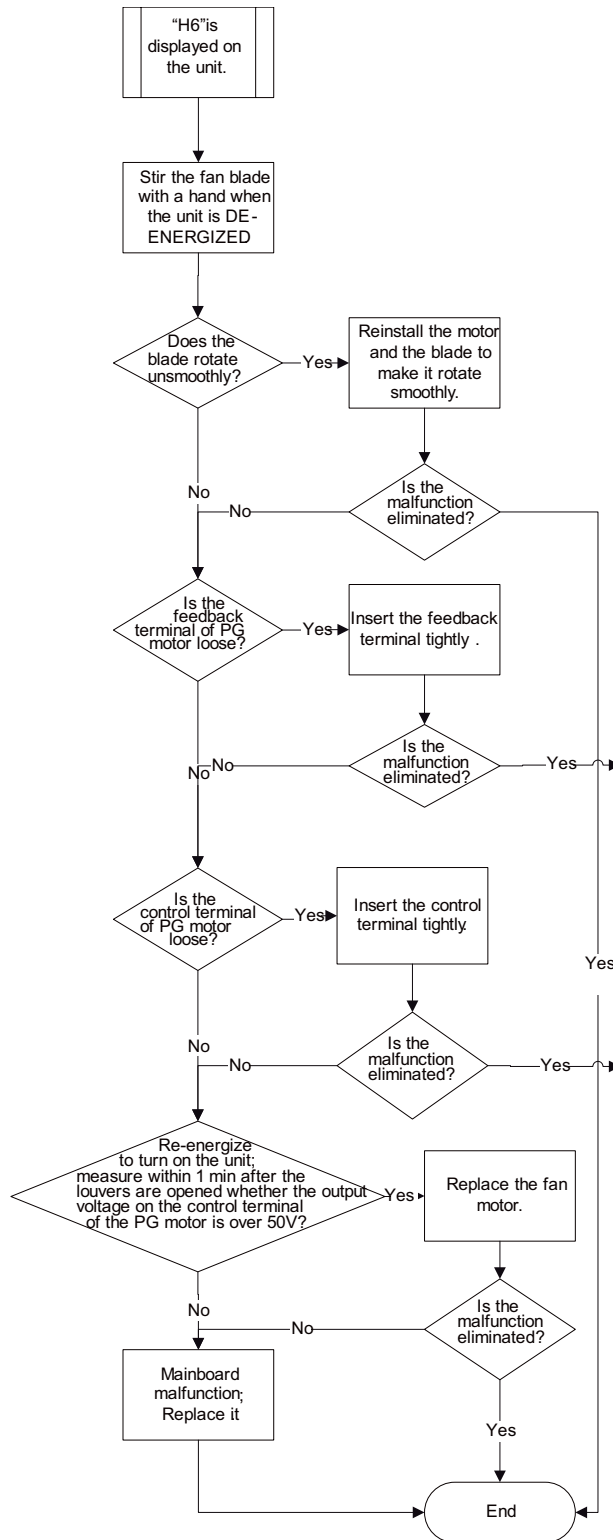

(3) Jumper cap malfunction (C5)

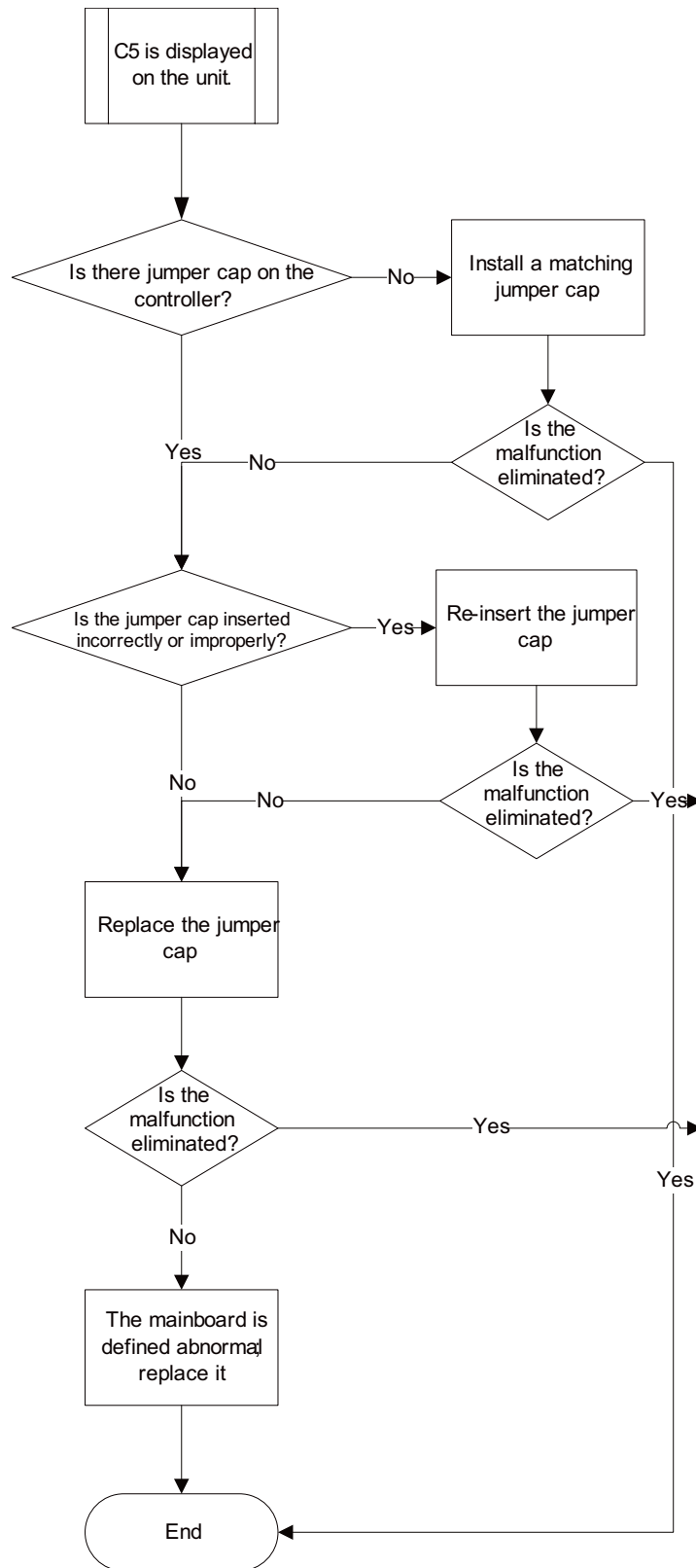

4.2 Outdoor unit:

(1)Key detection point

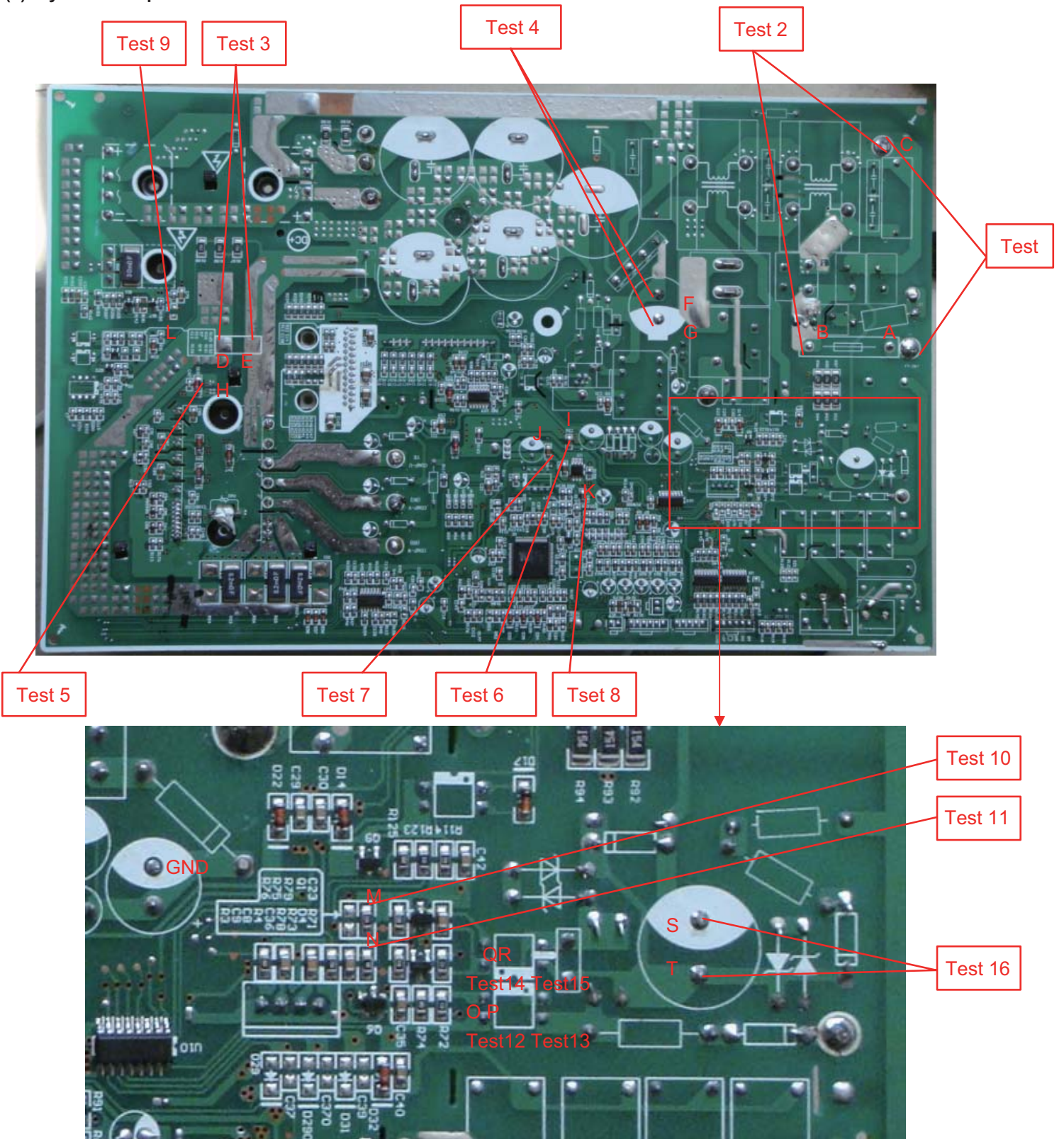

Test point No.	Test point	Corresponding component	Test value under normal situation
Test1	Between A and C	Neutral wire and live wire	160V~265V
Test2	Between B and C	Neutral wire and live wire	160V~265V
Test3	Between D and E	Electrolytic capacity of DC bus bar	180VDC~380VDC
Test4	Between F and G	Electrolytic capacity of switch power supply	180VDC~380VDC
Test5	Two terminal of diode D10	D10 (IPM modular+15V power supply)	14.5V~15.6VDC
Test6	Two terminal of flaky capacity C56	C56 (+12V power supply)	12V~13VDC
Test7	Two terminal of flaky capacity C58	C58 (+5V power supply)	5VDC
Test8	Two terminal of flaky capacity C83	C83 (+3.3V power supply)	3.3VDC
Test9	Two terminal of flaky capacity C80	C80 (+17V power supply)	15~18VDC
Test10	M forward to GND	M terminal of R75 forward to ground (outdoor signal send TXD)	Jump between 0-3.3V
Test11	N forward to GND	N terminal of R78 forward to ground (outdoor signal send RXD)	Jump between 0-3.3V
Test12	O	Receiving terminal of optical coupling (audion side)	Jump between 0.3-1.7V
Test13	P	Sending terminal of optical coupling (LBD side)	Jump between 0-1.1V
Test14	Q	Sending terminal of optical coupling (LBD side)	Jump between 0-1.1V
Test15	R	Receiving terminal of optical coupling (audion side)	Jump between 0-24V
Test16	Between S-T	Power supply of communication ring	56VDC

(2) Capacity charging malfunction (outdoor unit malfunction) (AP1 below is control board of outdoor unit)

Main detection point:

- Detect if the voltage of L and N terminal of wiring board is between 210AC-240AC by alternating voltage meter;
- Is reactor (L) well connected? Is connection wire loosened or pull-out? Is reactor (L) damaged?

Malfunction diagnosis process:

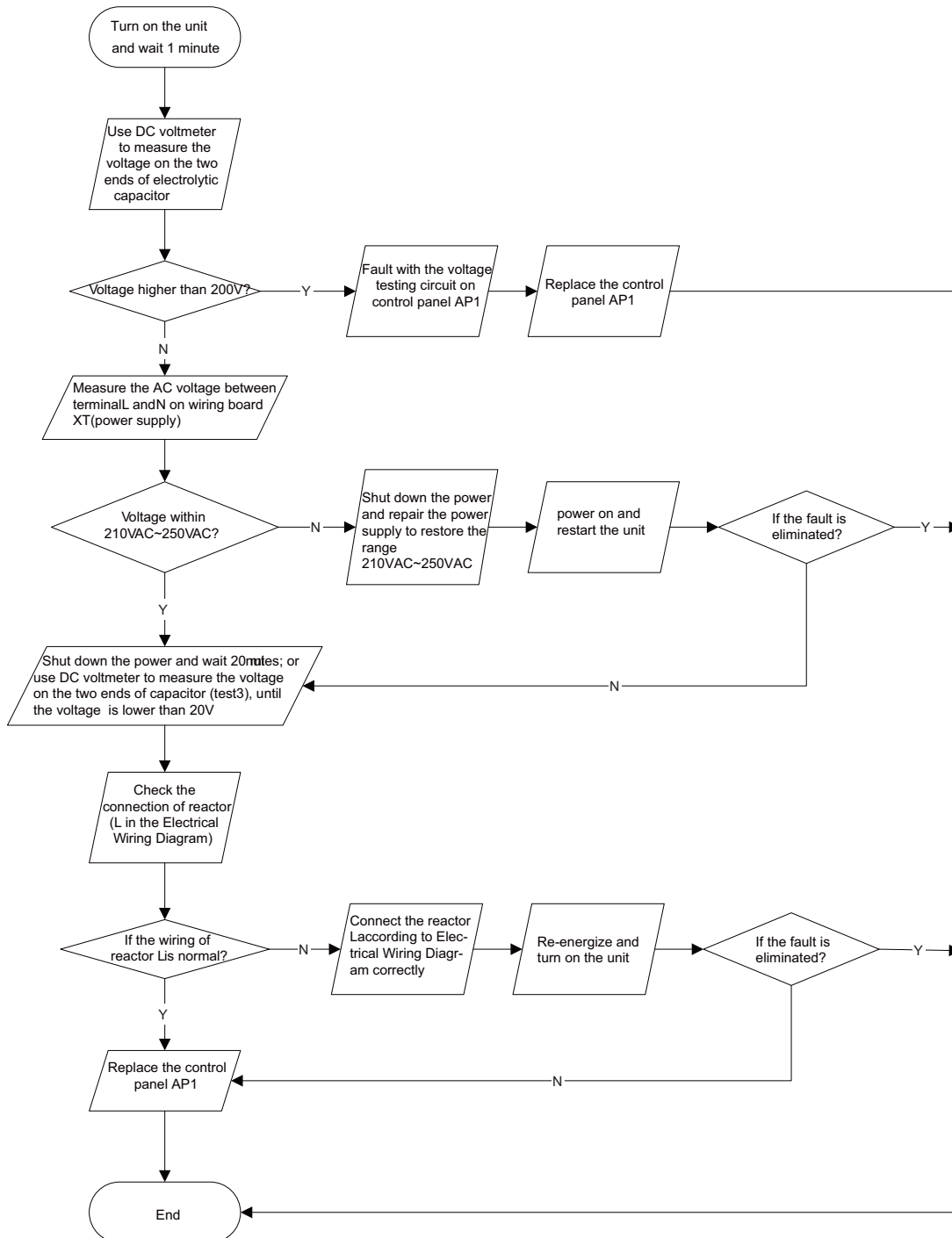

(3) IPM protection, desynchronizing malfunction, phase current of compressor is overcurrent (AP1 below is control board of outdoor unit)

Main detection point:

If control board AP1 and compressor COMP is well connected? If they are loosened? If the connection sequence is correct?

Is voltage input in the normal range (Test the voltage between L, N of wiring board XT by DC voltage meter)?

If coil resistance of compressor is normal? Is compressor coil insulating to copper pipe well?

If the work load of unit is heavy? If radiating of unit is well?

If the refrigerant charging is appropriate?

Malfunction diagnosis process:

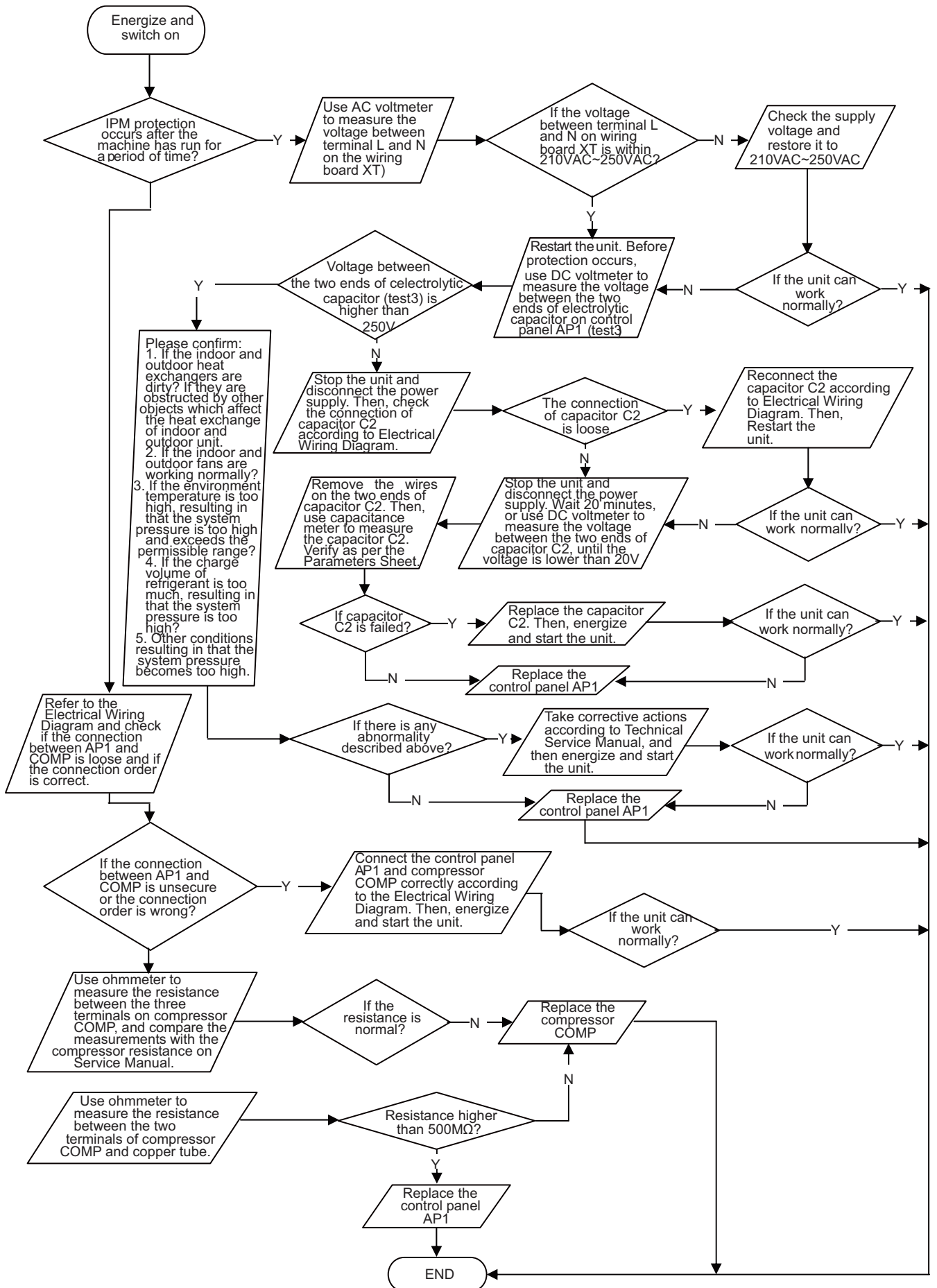

(4) Diagnosis for anti-high temperature, overload protection (AP1 below is control board of outdoor unit)

Main detection point:

- If the outdoor ambient temperature is in normal range;
- If the indoor and outdoor fan is running normal;
- If the radiating environment of indoor and outdoor unit is well.

Malfunction diagnosis process:

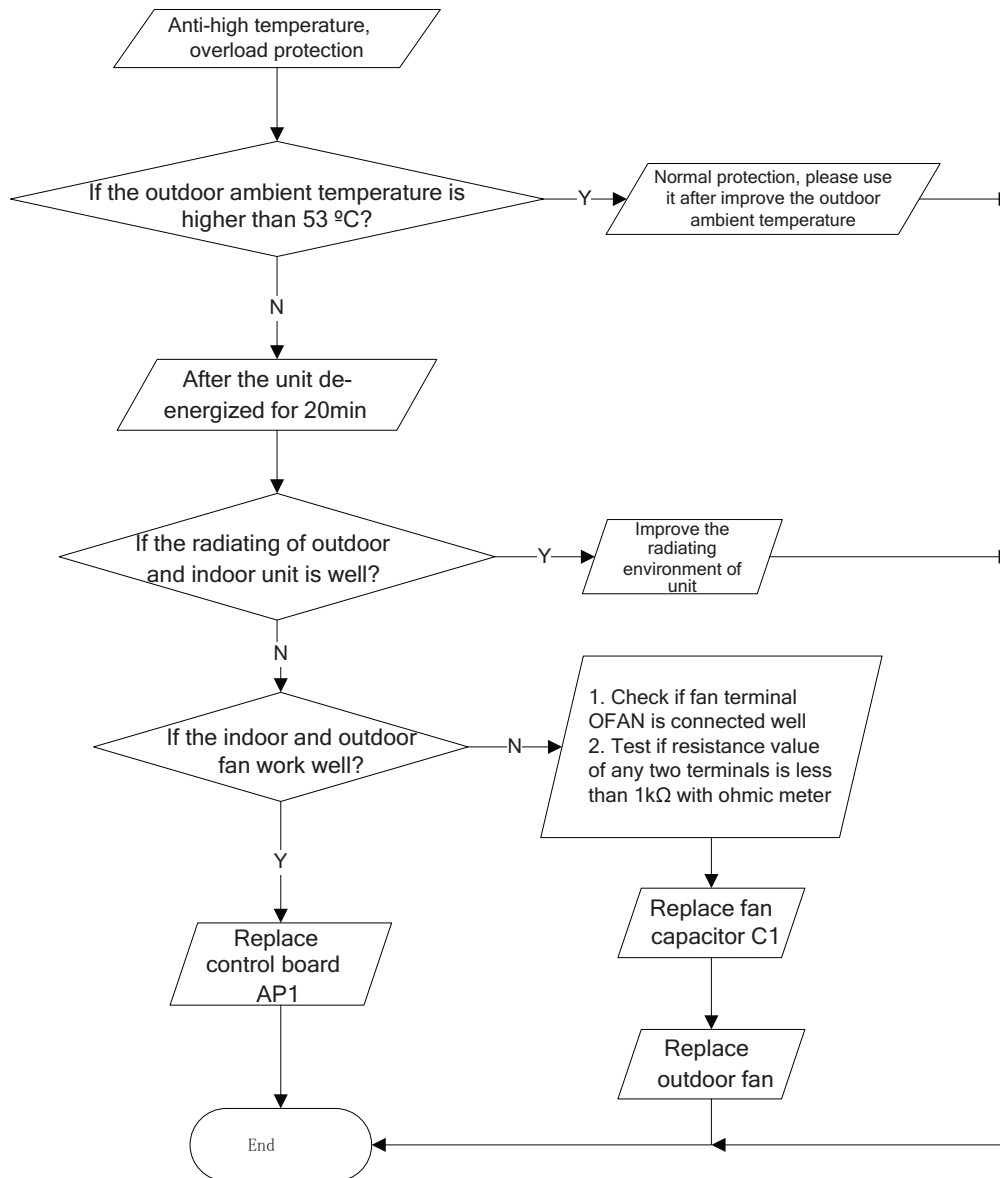

(5) Diagnosis for failure start up malfunction (AP1 below is control board of outdoor unit)

Main detection point:

- If the compressor wiring is correct?
- If the stop time of compressor is enough?
- If the compressor is damaged?
- If the refrigerant charging is too much?

Malfunction diagnosis process:

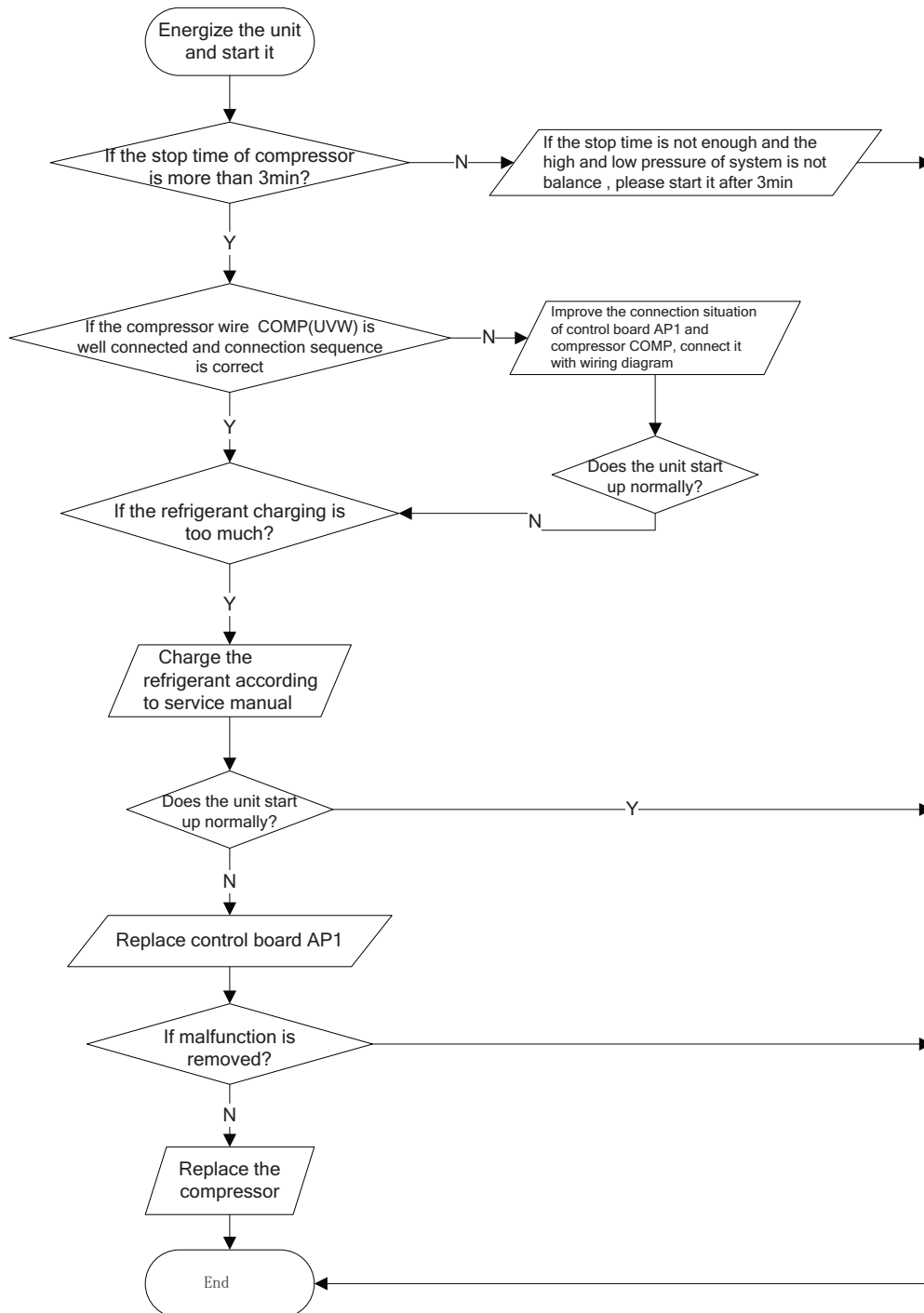

(6) Diagnosis for compressor synchronism (AP1 below is control board of outdoor unit)

Main detection point:

- If the system pressure is over-high?
- If the work voltage is over-low?

Malfunction diagnosis process:

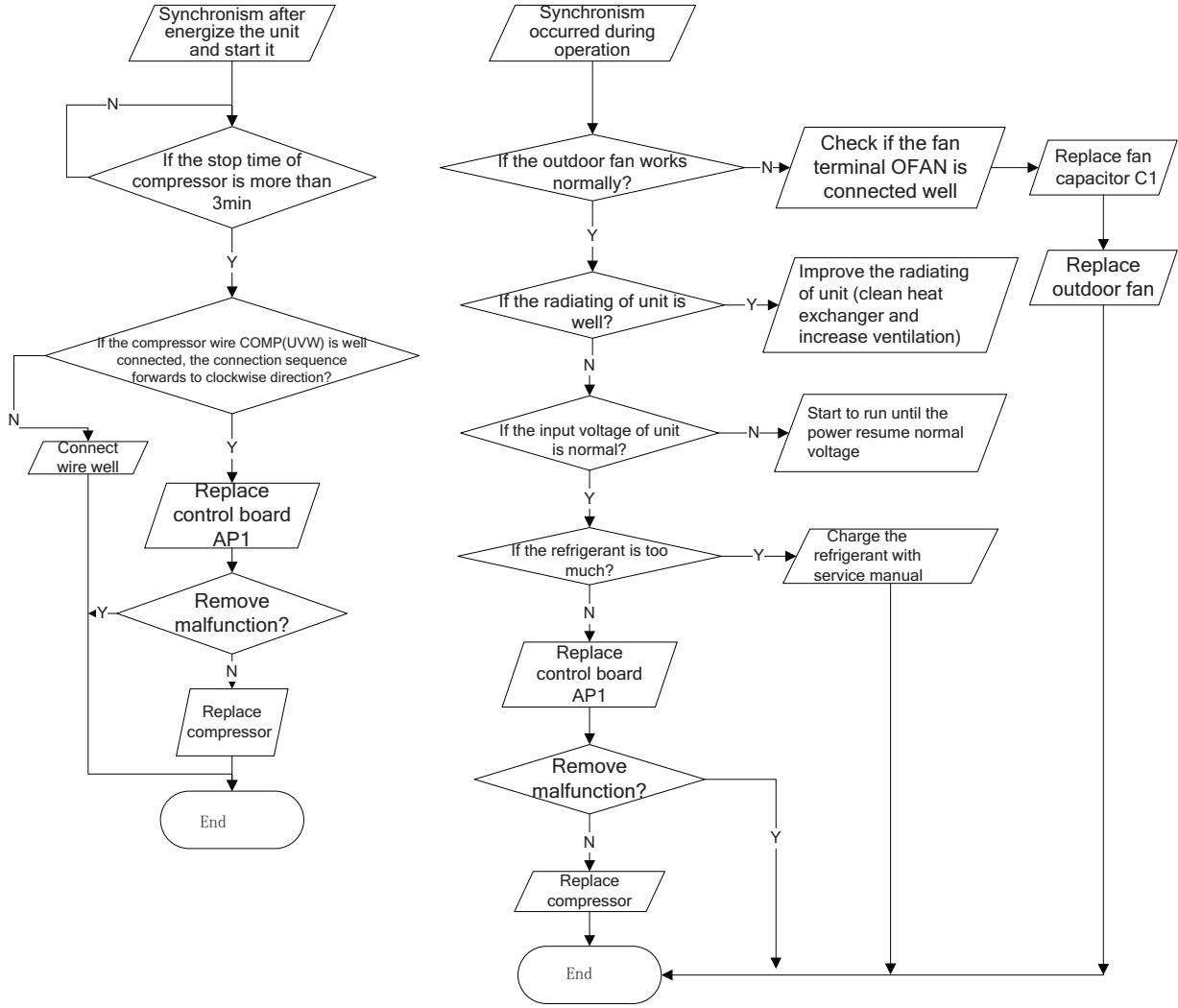

(7) Diagnosis for overload and discharge malfunction (AP1 below is control board of outdoor unit)

Main detection point:

- If the electron expansion valve is connected well? Is the expansion valve damaged?
- If the refrigerant is leakage?
- If the overload protector is damaged?

Malfunction diagnosis process:

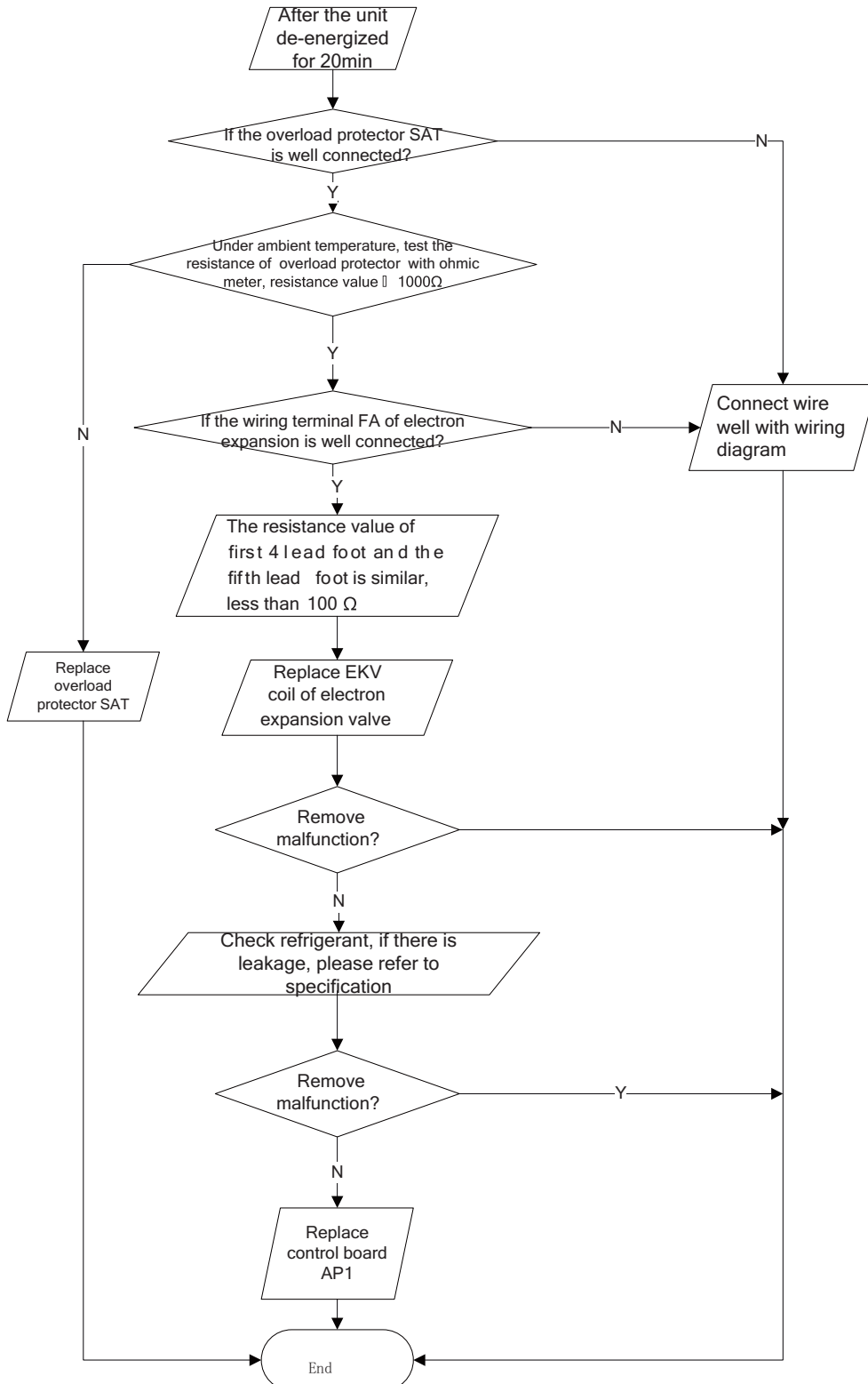

(8) PFC (correction for power factor) malfunction (outdoor unit malfunction) (AP1 below is control board of outdoor unit)

Main detection point:

- Check if reactor (L) of outdoor unit and PFC capacity are damaged

Malfunction diagnosis process:

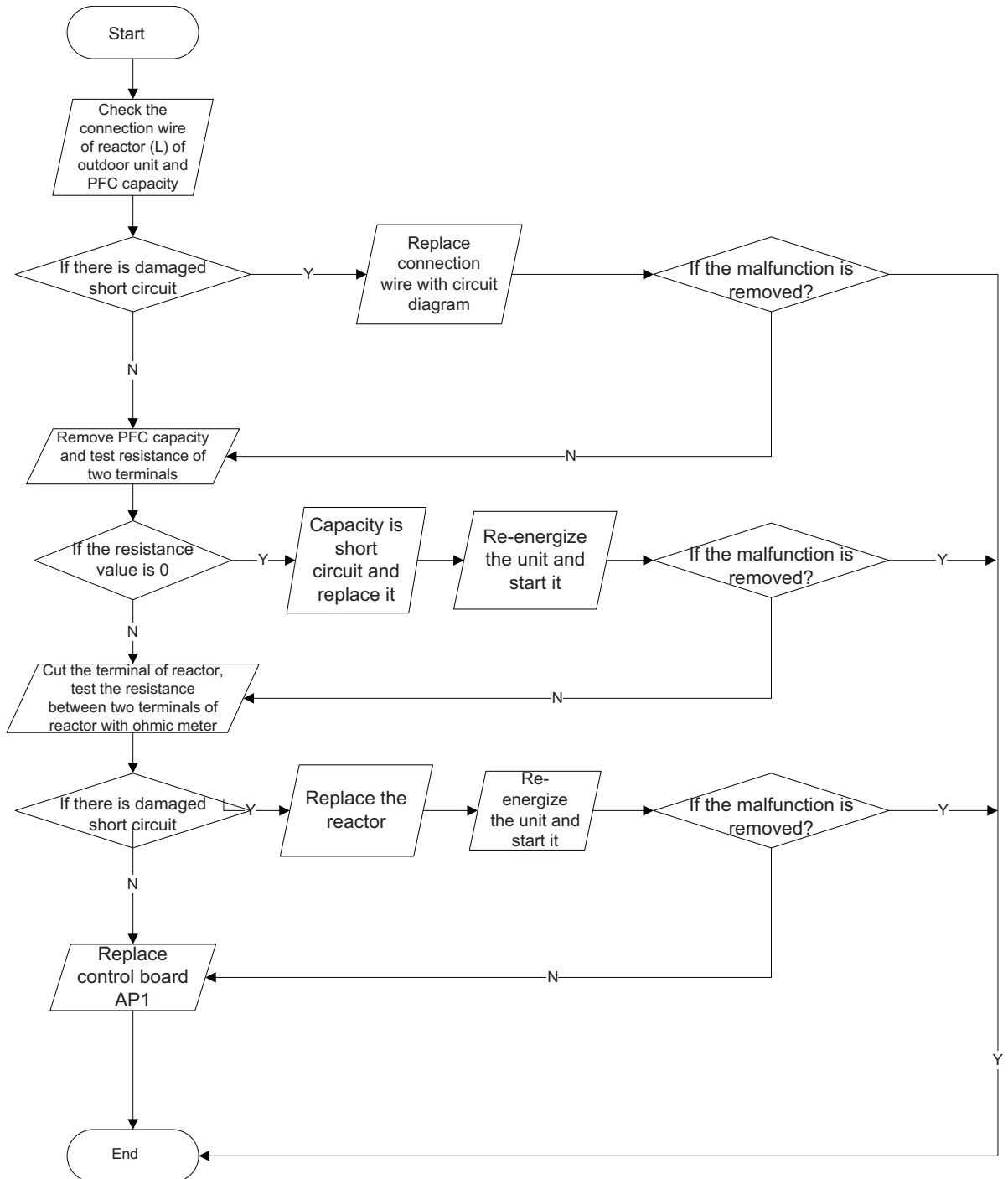

(9) Communication malfunction (AP1 below is control board of outdoor unit)

Main detection point:

- Check if the connection wire and the built-in wiring of indoor and outdoor unit is connected well and no damaged;
- If the communication circuit of indoor mainboard is damaged? If the communication circuit of outdoor mainboard (AP1) is damaged?

Malfunction diagnosis process:

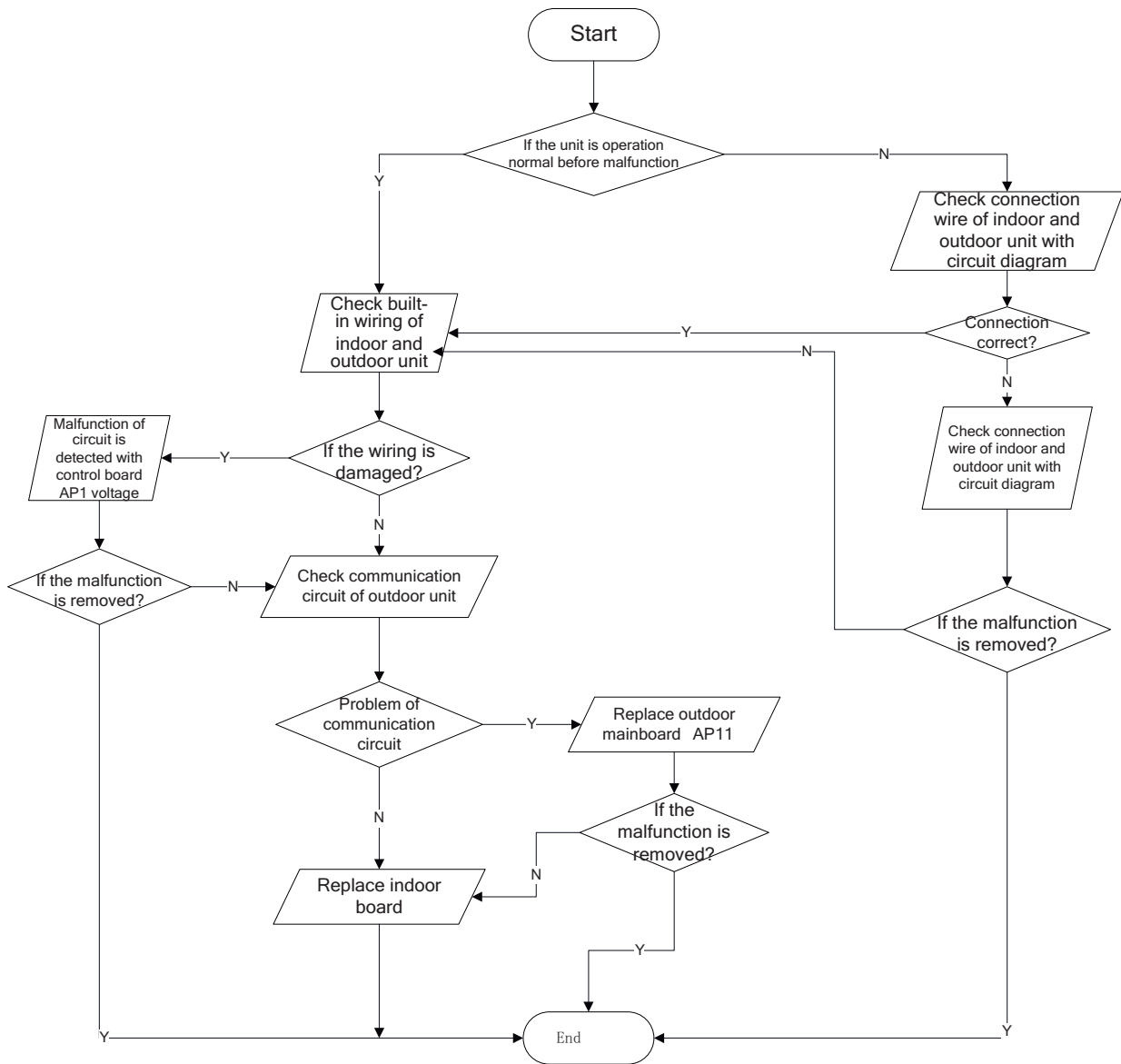

(10) Diagnosis process for outdoor communication circuit:

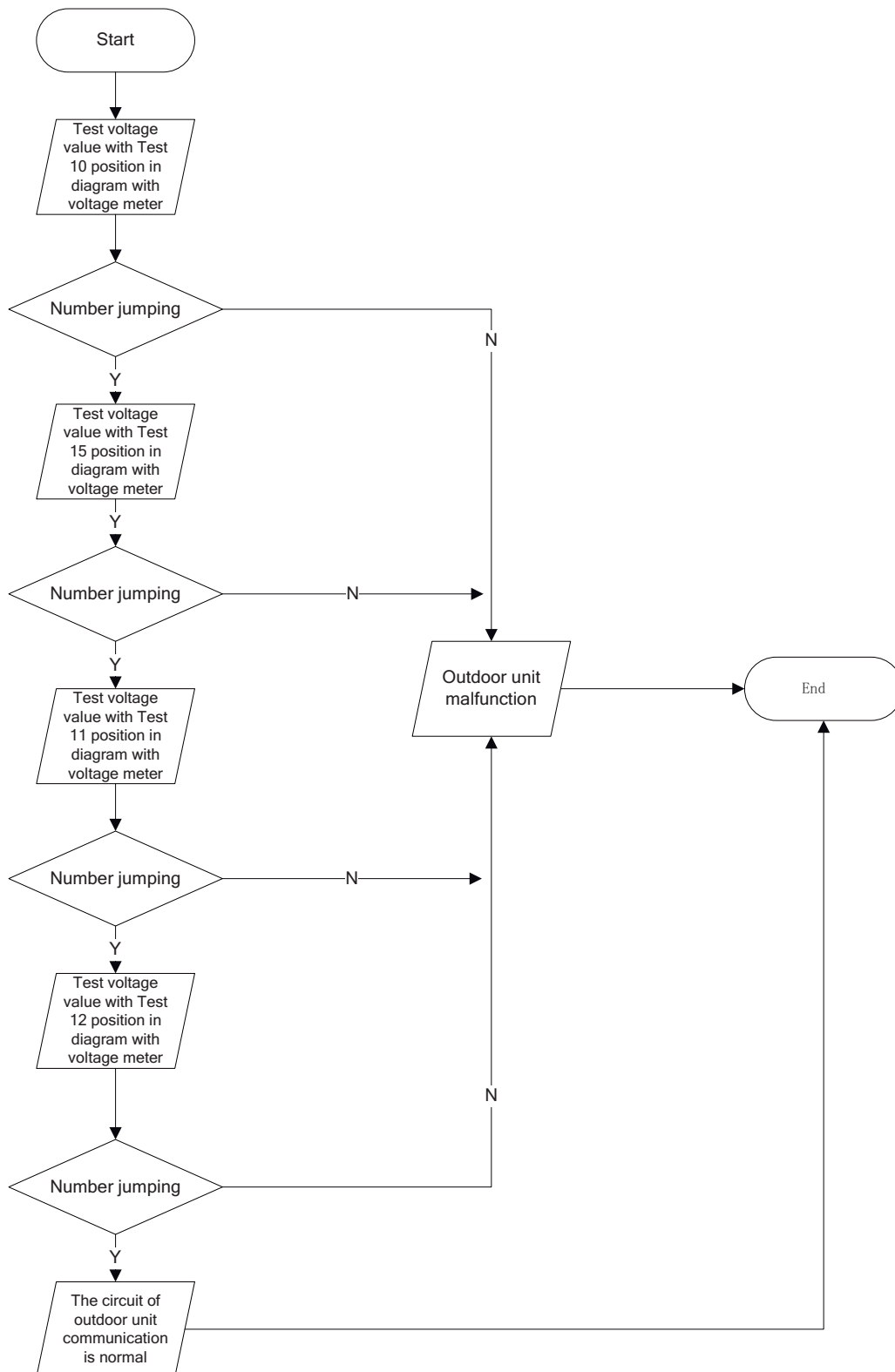

Appendix 1: Resistance Table of Ambient Temperature Sensor for Indoor and Outdoor Units

Temp.(°C)	Resistance (kΩ)	Temp.(°C)	Resistance (kΩ)	Temp.(°C)	Resistance (kΩ)	Temp.(°C)	Resistance (kΩ)
-19	138.1	20	18.75	59	3.848	98	1.071
-18	128.6	21	17.93	60	3.711	99	1.039
-17	121.6	22	17.14	61	3.579	100	1.009
-16	115	23	16.39	62	3.454	101	0.98
-15	108.7	24	15.68	63	3.333	102	0.952
-14	102.9	25	15	64	3.217	103	0.925
-13	97.4	26	14.36	65	3.105	104	0.898
-12	92.22	27	13.74	66	2.998	105	0.873
-11	87.35	28	13.16	67	2.896	106	0.848
-10	82.75	29	12.6	68	2.797	107	0.825
-9	78.43	30	12.07	69	2.702	108	0.802
-8	74.35	31	11.57	70	2.611	109	0.779
-7	70.5	32	11.09	71	2.523	110	0.758
-6	66.88	33	10.63	72	2.439	111	0.737
-5	63.46	34	10.2	73	2.358	112	0.717
-4	60.23	35	9.779	74	2.28	113	0.697
-3	57.18	36	9.382	75	2.206	114	0.678
-2	54.31	37	9.003	76	2.133	115	0.66
-1	51.59	38	8.642	77	2.064	116	0.642
0	49.02	39	8.297	78	1.997	117	0.625
1	46.6	40	7.967	79	1.933	118	0.608
2	44.31	41	7.653	80	1.871	119	0.592
3	42.14	42	7.352	81	1.811	120	0.577
4	40.09	43	7.065	82	1.754	121	0.561
5	38.15	44	6.791	83	1.699	122	0.547
6	36.32	45	6.529	84	1.645	123	0.532
7	34.58	46	6.278	85	1.594	124	0.519
8	32.94	47	6.038	86	1.544	125	0.505
9	31.38	48	5.809	87	1.497	126	0.492
10	29.9	49	5.589	88	1.451	127	0.48
11	28.51	50	5.379	89	1.408	128	0.467
12	27.18	51	5.197	90	1.363	129	0.456
13	25.92	52	4.986	91	1.322	130	0.444
14	24.73	53	4.802	92	1.282	131	0.433
15	23.6	54	4.625	93	1.244	132	0.422
16	22.53	55	4.456	94	1.207	133	0.412
17	21.51	56	4.294	95	1.171	134	0.401
18	20.54	57	4.139	96	1.136	135	0.391
19	19.63	58	3.99	97	1.103	136	0.382

Appendix 2: Resistance Table of Outdoor and Indoor Tube Temperature Sensors

Temp.(°C)	Resistance (kΩ)		Temp.(°C)	Resistance (kΩ)		Temp.(°C)	Resistance (kΩ)		Temp.(°C)	Resistance (kΩ)
-19	181.4		20	25.01		59	5.13		98	1.427
-18	171.4		21	23.9		60	4.948		99	1.386
-17	162.1		22	22.85		61	4.773		100	1.346
-16	153.3		23	21.85		62	4.605		101	1.307
-15	145		24	20.9		63	4.443		102	1.269
-14	137.2		25	20		64	4.289		103	1.233
-13	129.9		26	19.14		65	4.14		104	1.198
-12	123		27	18.13		66	3.998		105	1.164
-11	116.5		28	17.55		67	3.861		106	1.131
-10	110.3		29	16.8		68	3.729		107	1.099
-9	104.6		30	16.1		69	3.603		108	1.069
-8	99.13		31	15.43		70	3.481		109	1.039
-7	94		32	14.79		71	3.364		110	1.01
-6	89.17		33	14.18		72	3.252		111	0.983
-5	84.61		34	13.59		73	3.144		112	0.956
-4	80.31		35	13.04		74	3.04		113	0.93
-3	76.24		36	12.51		75	2.94		114	0.904
-2	72.41		37	12		76	2.844		115	0.88
-1	68.79		38	11.52		77	2.752		116	0.856
0	65.37		39	11.06		78	2.663		117	0.833
1	62.13		40	10.62		79	2.577		118	0.811
2	59.08		41	10.2		80	2.495		119	0.77
3	56.19		42	9.803		81	2.415		120	0.769
4	53.46		43	9.42		82	2.339		121	0.746
5	50.87		44	9.054		83	2.265		122	0.729
6	48.42		45	8.705		84	2.194		123	0.71
7	46.11		46	8.37		85	2.125		124	0.692
8	43.92		47	8.051		86	2.059		125	0.674
9	41.84		48	7.745		87	1.996		126	0.658
10	39.87		49	7.453		88	1.934		127	0.64
11	38.01		50	7.173		89	1.875		128	0.623
12	36.24		51	6.905		90	1.818		129	0.607
13	34.57		52	6.648		91	1.736		130	0.592
14	32.98		53	6.403		92	1.71		131	0.577
15	31.47		54	6.167		93	1.658		132	0.563
16	30.04		55	5.942		94	1.609		133	0.549
17	28.68		56	5.726		95	1.561		134	0.535
18	27.39		57	5.519		96	1.515		135	0.521
19	26.17		58	5.32		97	1.47		136	0.509

Appendix 3: Resistance Table of Outdoor Discharge Temperature Sensor

Temp.(°C)	Resistance (kΩ)	Temp.(°C)	Resistance (kΩ)	Temp.(°C)	Resistance (kΩ)	Temp.(°C)	Resistance (kΩ)
-29	853.5	10	98	49	18.34	88	4.754
-28	799.8	11	93.42	50	17.65	89	4.609
-27	750	12	89.07	51	16.99	90	4.469
-26	703.8	13	84.95	52	16.36	91	4.334
-25	660.8	14	81.05	53	15.75	92	4.204
-24	620.8	15	77.35	54	15.17	93	4.079
-23	580.6	16	73.83	55	14.62	94	3.958
-22	548.9	17	70.5	56	14.09	95	3.841
-21	516.6	18	67.34	57	13.58	96	3.728
-20	486.5	19	64.33	58	13.09	97	3.619
-19	458.3	20	61.48	59	12.62	98	3.514
-18	432	21	58.77	60	12.17	99	3.413
-17	407.4	22	56.19	61	11.74	100	3.315
-16	384.5	23	53.74	62	11.32	101	3.22
-15	362.9	24	51.41	63	10.93	102	3.129
-14	342.8	25	49.19	64	10.54	103	3.04
-13	323.9	26	47.08	65	10.18	104	2.955
-12	306.2	27	45.07	66	9.827	105	2.872
-11	289.6	28	43.16	67	9.489	106	2.792
-10	274	29	41.34	68	9.165	107	2.715
-9	259.3	30	39.61	69	8.854	108	2.64
-8	245.6	31	37.96	70	8.555	109	2.568
-7	232.6	32	36.38	71	8.268	110	2.498
-6	220.5	33	34.88	72	7.991	111	2.431
-5	209	34	33.45	73	7.726	112	2.365
-4	198.3	35	32.09	74	7.47	113	2.302
-3	199.1	36	30.79	75	7.224	114	2.241
-2	178.5	37	29.54	76	6.998	115	2.182
-1	169.5	38	28.36	77	6.761	116	2.124
0	161	39	27.23	78	6.542	117	2.069
1	153	40	26.15	79	6.331	118	2.015
2	145.4	41	25.11	80	6.129	119	1.963
3	138.3	42	24.13	81	5.933	120	1.912
4	131.5	43	23.19	82	5.746	121	1.863
5	125.1	44	22.29	83	5.565	122	1.816
6	119.1	45	21.43	84	5.39	123	1.77
7	113.4	46	20.6	85	5.222	124	1.725
8	108	47	19.81	86	5.06	125	1.682
9	102.8	48	19.06	87	4.904	126	1.64

9.5 2-way, 3-way Valve Appearance

		2-way Valve (Liquid Side)	3-way Valve (Gas Side)	
Works		Shaft position	Shaft position	Service port
Shipping		Closed (with valve cap)	Closed (with valve cap)	Closed (with cap)
1.	Air purging (Installation)	Closed (clockwise)	Closed (clockwise)	Open (with vacumm pump)
Operation		Open (with valve cap)	Open (with valve cap)	Closed (with cap)
2.	Pumping down (Transferring)	Closed (clockwise)	Open (counter-clockwise)	Open (connected manifold gauge)
3.	Evacuation (Servicing)	Open	Open	Open (with charging cylinder)
4.	Gas charging (Servicing)	Open	Open	Open (with charging cylinder)
5.	Pressure check (Servicing)	Open	Open	Open (with charging cylinder)
6.	Gas releasing (Servicing)	Open	Open	Open (with charging cylinder)

Air purging

CAUTION: Do not leak the gas in the air during Air purging.

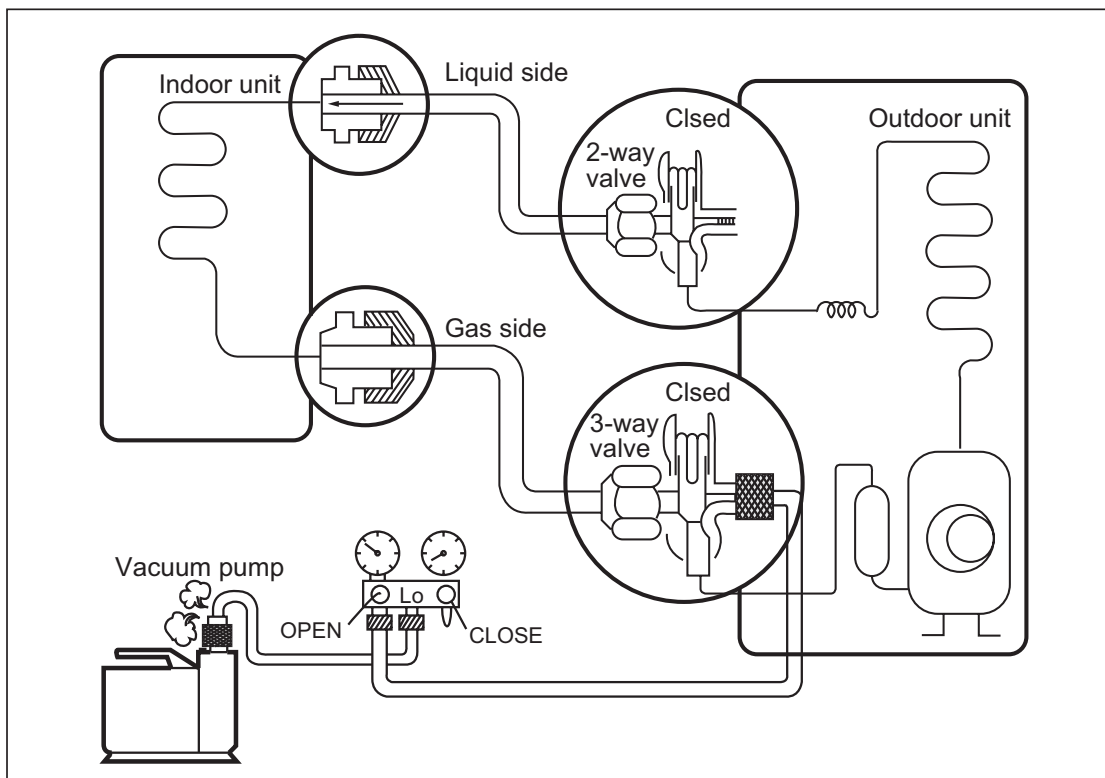

*** Procedure**

- (1) Connect the charge hose from the manifold valve to the service port of the gas side packed valve.
- (2) Connect the charge hose to the port of the vacuum pump.
- (3) Open fully the low pressure side handle of the gauge manifold valve.
- (4) Operate the vacuum pump to begin evacuating. Perform evacuating for about 15 minutes if the piping length is 20 meters (15 minutes for 20 meters) (assuming a pump capacity of 27 liters per minute). Confirm that the compound pressure gauge reading is -101 kPa (-76 cmHg).
- (5) Close the low pressure valve handle of gauge manifold.
 - Check the flare connections for gas leakage.
- (6) Use torque wrench to tighten the service port nut to a torque of 1.8 kg.cm .
- (7) Set the 3-way valve to the back seat.
- (8) Mount the valve stem nuts to the 2-way and 3-way valves.
- (9) Check for gas leakage.
 - At this time, especially check for gas leakage from the 2-way and 3-way valves stem nuts, and from the service port nut.

CAUTION:

If gas leakage are discovered in step 5 above, take the following measures :

If the gas leaks stop when the piping connections are tightened further, continue working from step 6. If the gas leaks do not stop when the connections are retightened, repair the location of the leak, discharge all of the gas through the service port, and then recharge with the specified amount of gas from a gas cylinder.

Pumping Down

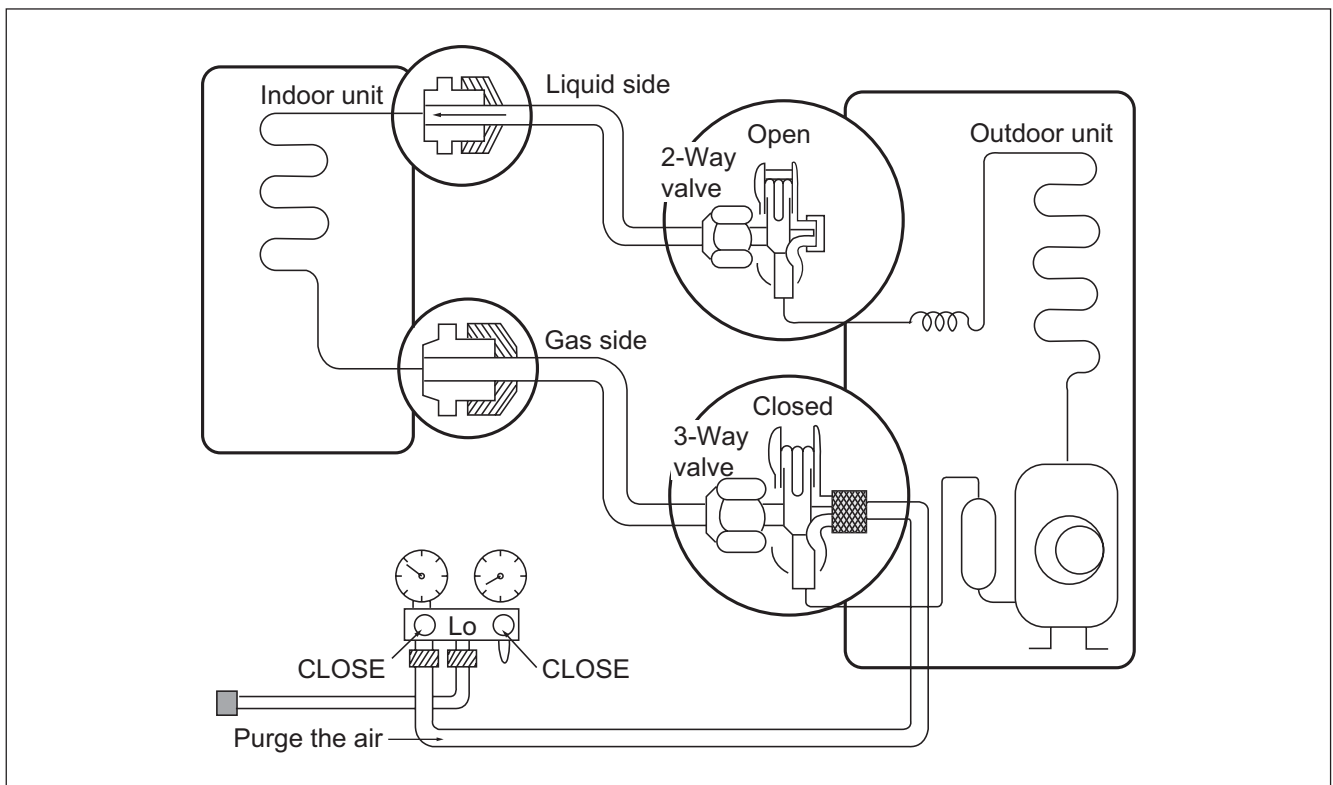

• Procedure

(1) Confirm that both the 2-way and 3-way valves are set to the open position.

- Remove the valve stem caps and confirm that the valve stems are in the raised position.
- Be sure to use a hexagonal wrench to operate the valve stems.

(2) Operate the unit for 10 to 15 minutes.

(3) Stop operation and wait for 3 minutes, then connect the charge set to the service port of the 3-way valve.

- Connect the charge hose with the push pin to the service port.

(4) Air purging of the charge hose.

- Open the low-pressure valve on the charge set slightly to air purge from the charge hose.

(5) Set the 2-way valve to the closed position.

(6) Operate the air conditioner at the cooling cycle and stop it when the gauge indicates 1kg/cm²g.

(7) Immediately set the 3-way valve to the closed position.

- Do this quickly so that the gauge ends up indicating 3 to 5kg/cm²g.

(8) Disconnect the charge set, and mount the 2-way and 3-way valves stem nuts and the service port nut.

- Use torque wrench to tighten the service port nut to a torque of 1.8 kg.m.
- Be sure to check for gas leakage.

Re-air Purging

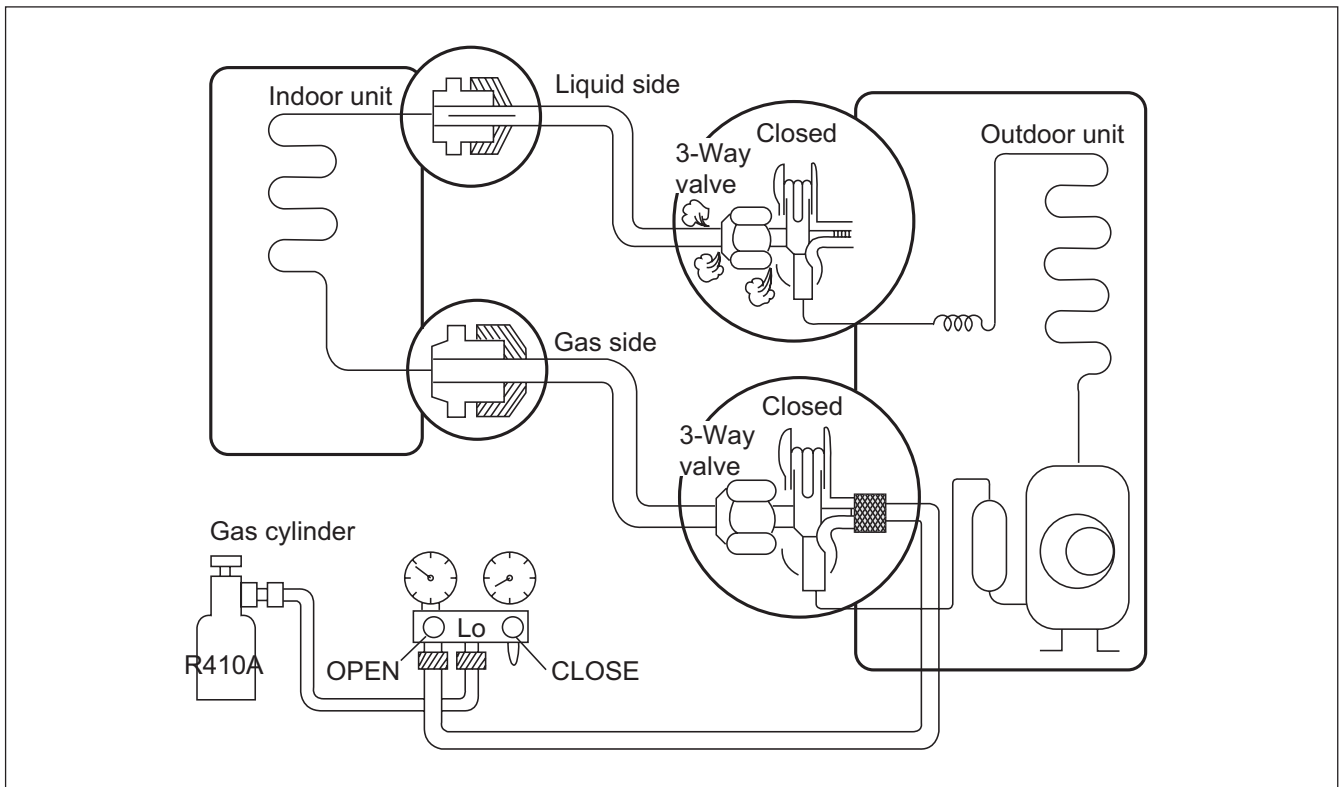

• Procedure

(1) Confirm that both the liquid side valve and the gas side valve are set to the closed position.

(2) Connect the charge set and a gas cylinder to the service port of the Gas side valve.

– Leave the valve on the gas cylinder closed.

(3) Air purging.

– Open the valves on the gas cylinder and the charge set. Purge the air by loosening the flare nut on the liquid side valve approximately 45° or 3 seconds then closing it for 1 minute; repeat 3 times.

– After purging the air, use a torque wrench to tighten the flare nut on liquid side valve.

(4) Check for gas leakage.

– Check the flare connections for gas leakage.

(5) Discharge the refrigerant.

– Close the valve on the gas cylinder and discharge the refrigerant until the gauge indicates 3 to 5 kg/cm²g.

(6) Disconnect the charge set and the gas cylinder, and set the Liquid side and Gas side valves to the open position.

– Be sure to use a hexagonal wrench to operate the valve stems.

(8) Mount the valve stem nuts and the service port nut.

– Use torque wrench to tighten the service port nut to a torque of 1.8 kg.m.

– Be sure to check for gas leakage.

CAUTION: Do not leak the gas in the air during Air Purging.

**Balance Refrigerant of the 3-way Valve
(Gas leakage)**

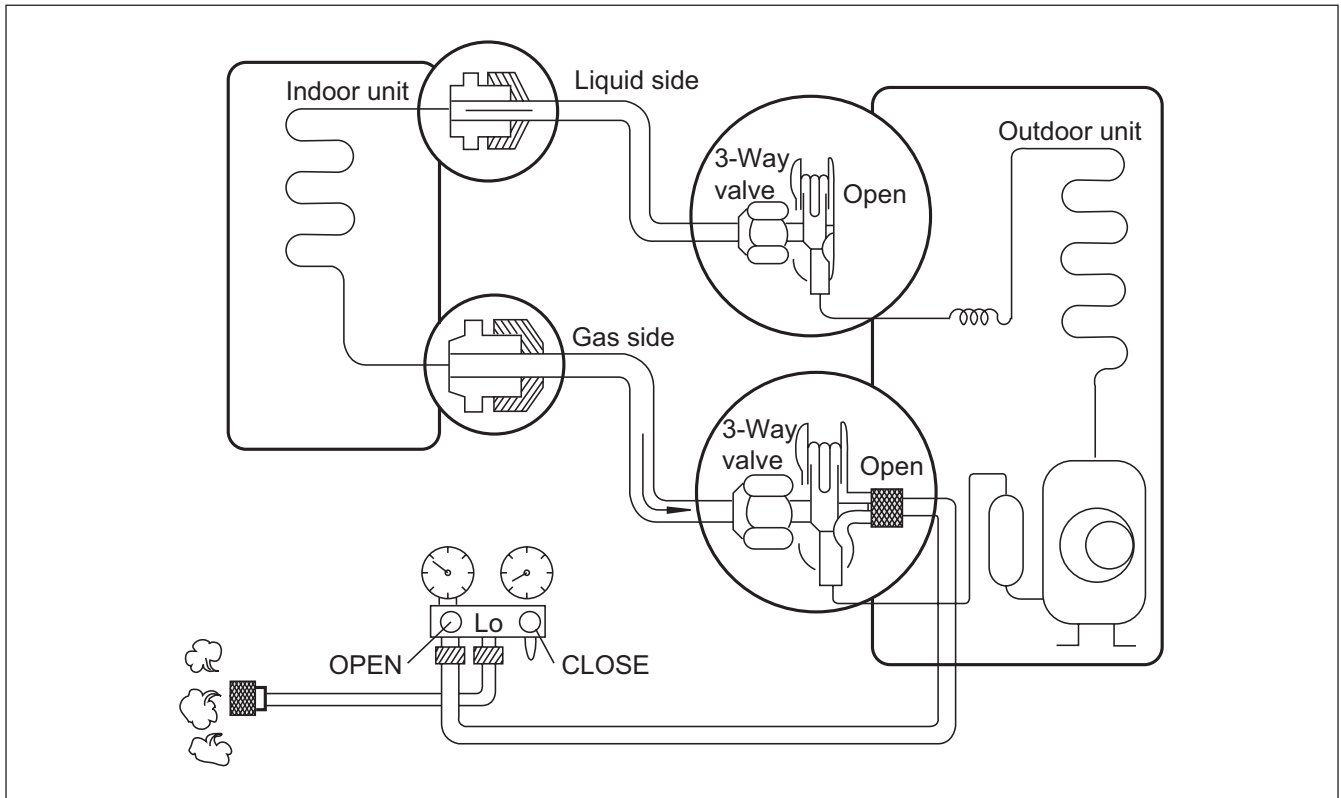

• Procedure

(1) Confirm that both the 2-way and 3-way valves are set to the back seat.

(2) Connect the charge set to the 3-way valves port.

- Leave the valve on the charge set closed.
- Connect the charge hose to the service port.

(3) Open the valve (Lo side) on the charge set and discharge the refrigerant until the gauge indicates 0 kg/cm²G.

- If there is no air in the refrigerant cycle (the pressure when the air conditioner is not running is higher than 1kg/cm²G), discharge the refrigerant until the gauge indicates 0.5 to 1kg/cm²G. if this is the case, it will not be necessary to apply a evacuation.
- Discharge the refrigerant gradually; if it is discharged too suddenly, the refrigeration oil will also be discharged.

Evacuation

(All amount of refrigerant leaked)

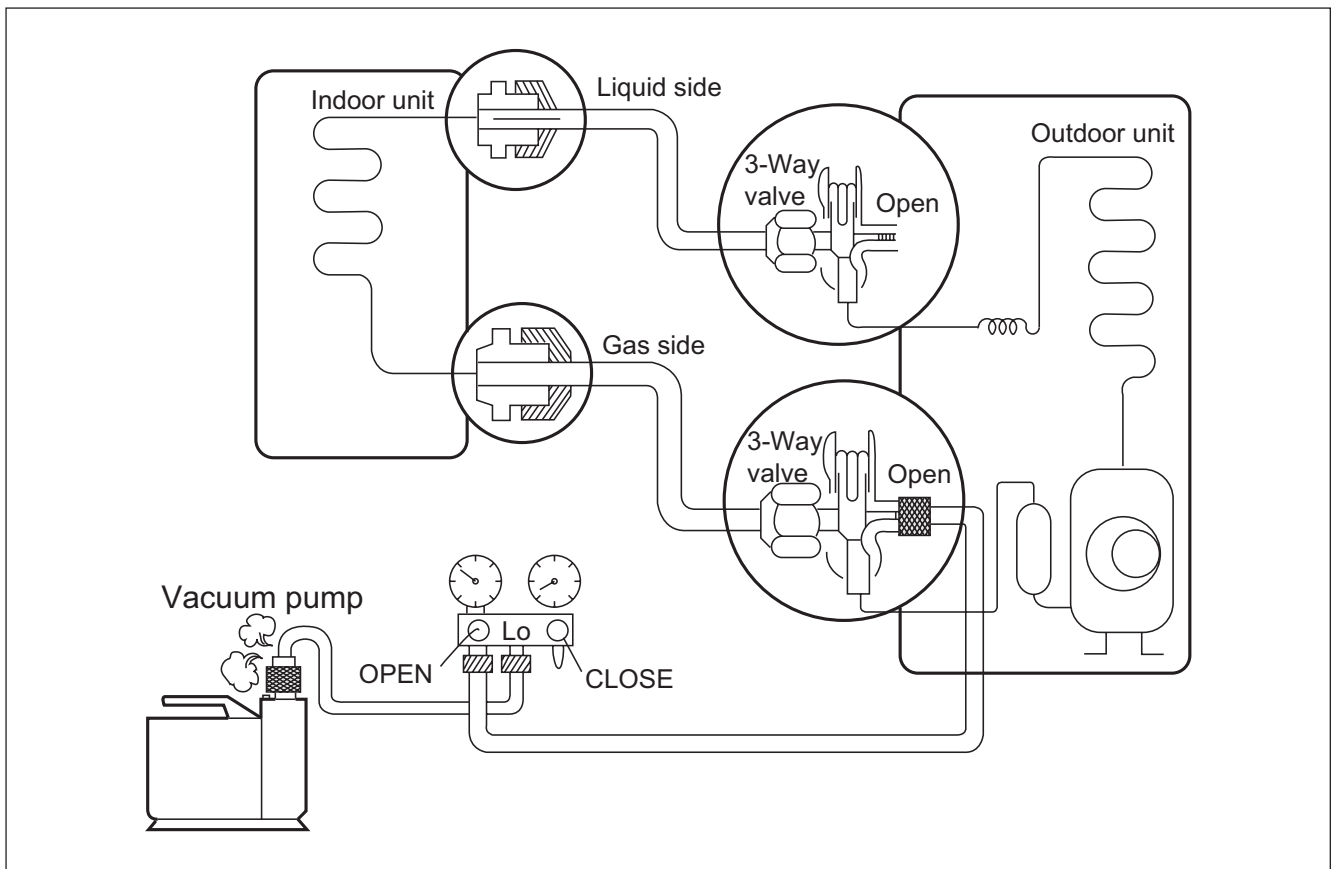

• Procedure

(1) Connect the vacuum pump to the center hose of charge set center hose

(2) Evacuation for approximately one hour.

– Confirm that the gauge needle has moved toward -76cmHg (vacuum of 4 mmHg or less).

(3) Close the valve (Lo side) on the charge set, turn off the vacuum pump, and confirm that the gauge needle does not move (approximately 5 minutes after turning off the vacuum pump).

(4) Disconnect the charge hose from the vacuum pump.

– Vacuum pump oil.

If the vacuum pump oil becomes dirty or depleted, replenish as needed.

**Gas Charging
(After Evacuation)**

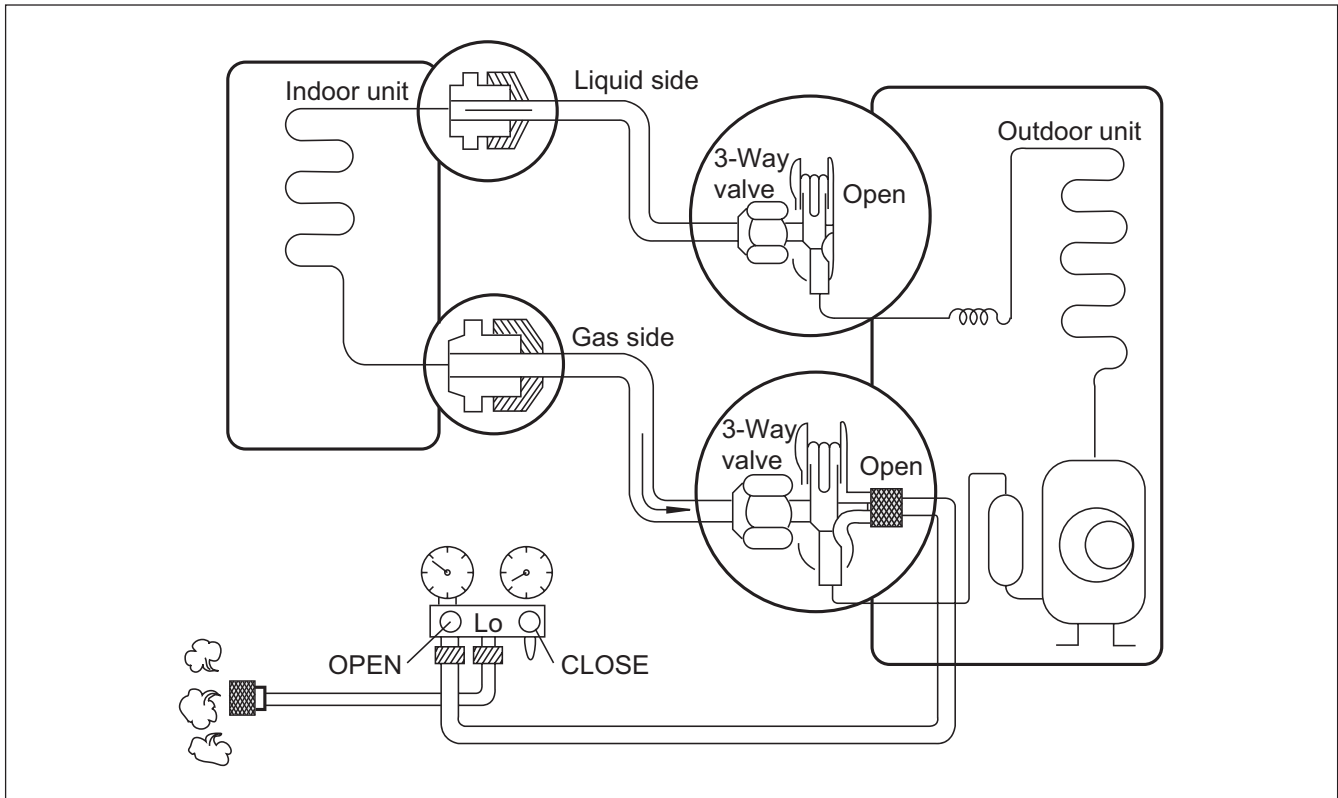

• Procedure

(1) Connect the charge hose to the charging cylinder.

- Connect the charge hose which you dis-connected from the vacuum pump to the valve at the bottom of the cylinder.
- If you are using a gas cylinder, also use a scale and reverse the cylinder so that the system can be charged with liquid.

(2) Purge the air from the charge hose.

- Open the valve at the bottom of the cylinder and press the check valve on the charge set to purge the air. (Be careful of the liquid refrigerant).

(3) Open the valve (Lo side on the charge set and charge the system with liquid refrigerant.

- If the system can not be charged with the specified amount of refrigerant, it can be charged with a little at a time (approximately 150g each time) while operating the air conditioner in the cooling cycle; however, one time is not sufficient, wait approximately 1 minute and then repeat the procedure (pumping down-pin).

This is different from previous procedures. Because you are charging with liquid refrigerant from the gas side, absolutely do not attempt to charge with larger amounts of liquid refrigerant while operating the air conditioner.

(4) Immediately disconnect the charge hose from the 3-way valves service port.

- Stopping partway will allow the gas to be discharged.
- If the system has been charged with liquid refrigerant while operating the air conditioner turn off the air conditioner before disconnecting the hose.

(5) Mount the valve stem nuts and the service port nut.

- Use torque wrench to tighten the service port nut to a torque of 1.8 kg.m.
- Be sure to check for gas leakage.

Note: The above information are only for reference.

10. Removal Procedure

10.1 Removal Procedure of Indoor Unit



Warning Be sure to wait for a minimum of 10 minutes after turning off all power supplies before disassembly.

Only take the indoor fan of 18K as an example.

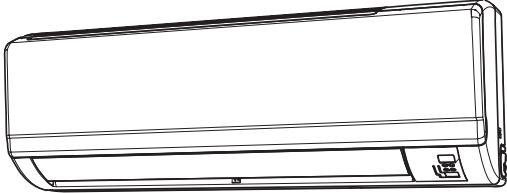
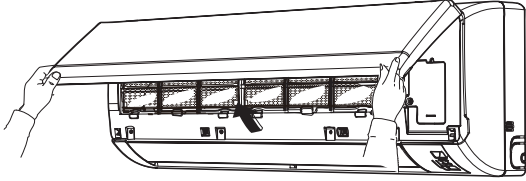
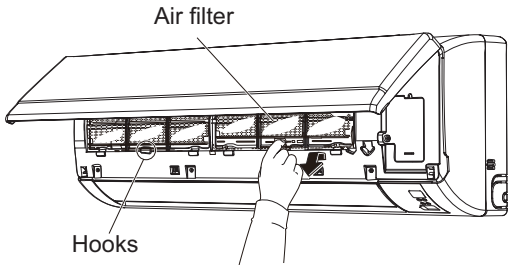
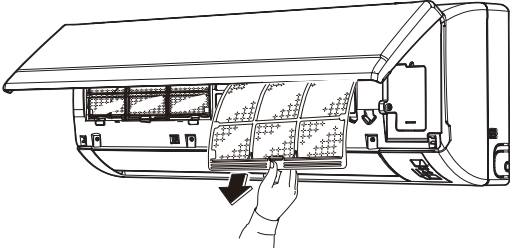
Step	Procedure	Points
1. External features		<ul style="list-style-type: none"> ■ If ON/OFF button is kept pushing for 5 seconds, a forced cooling operation will be carried out for approx. 15 minutes.
2. Removing air filters		
1	<p>Pull protrusions on left and right sides of panel with fingers and open front panel all the way.</p> 	
2	<p>Lift center section of air filter and disengage hooks.</p> 	<ul style="list-style-type: none"> ■ Left and right filters are interchangeable.
3	<p>Remove air filter by pulling forward.</p> 	<ul style="list-style-type: none"> ■ To re-install, insert air filter along the guide.

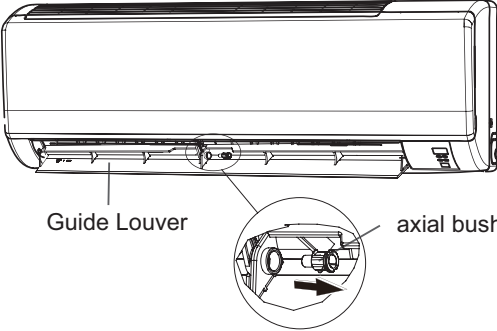
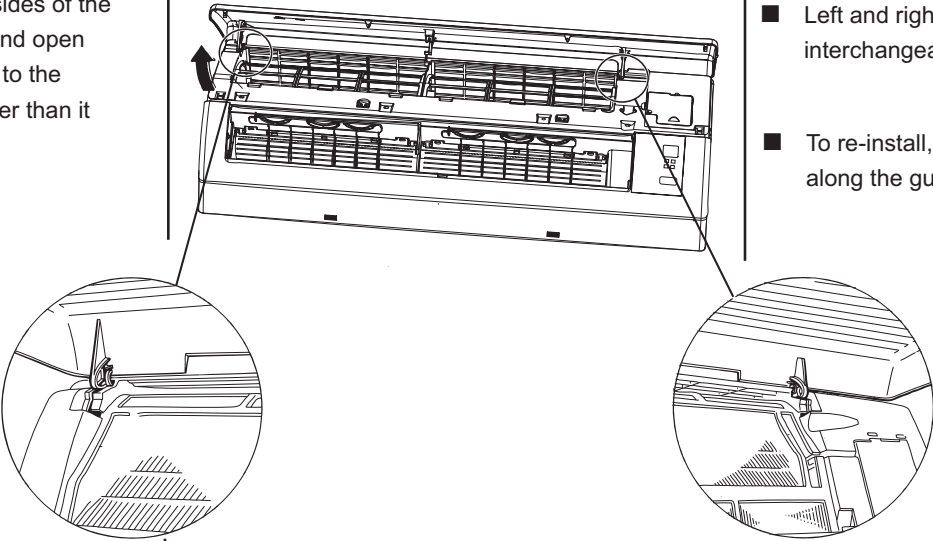
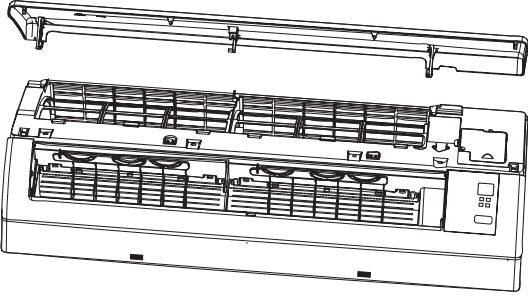
Step	Procedure	Points
3. Opening and shutting front panel		
1	<p>Draw out the axial bush. Bend the horizontal louver slightly and then remove it.</p> 	<ul style="list-style-type: none"> ■ Support the front panel by one hand, while remove the rotation axis at the upper center by the other hand.
2	<p>Hook a finger onto the projection part provided on the both sides of the units panel and open up the panel to the position higher than it will stop.</p> 	<ul style="list-style-type: none"> ■ Left and right filters are interchangeable. ■ To re-install, insert air filter along the guide.
3	<p>Remove the front panel from the unit.</p> 	

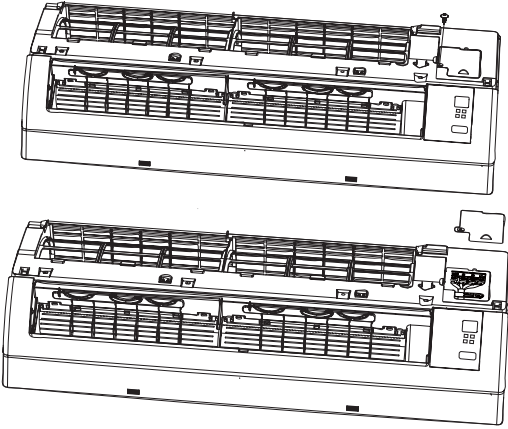
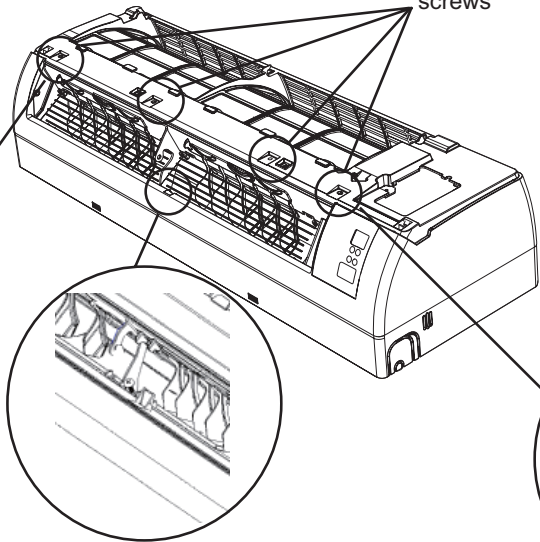
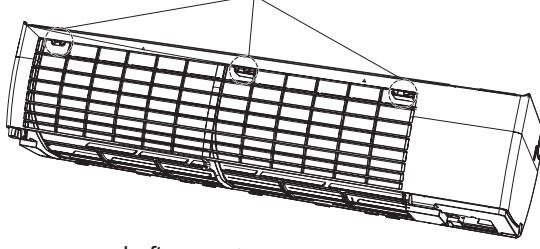
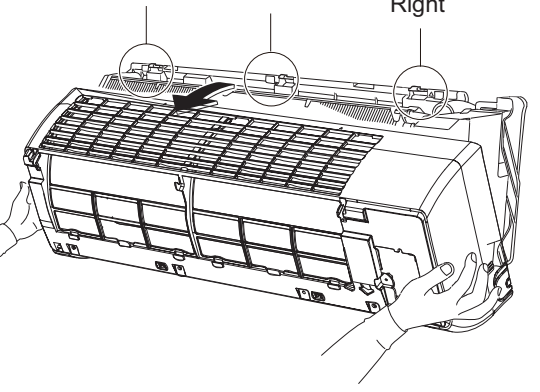
Step	Procedure	Points
4. Opening and closing of service cover	<p data-bbox="193 338 432 472">1 Remove a service cover mounting screw. Open service cover upward.</p> 	<ul style="list-style-type: none"> ■ A switch for field setting is not provided in particular.
5. Removal of front grille assembly	<p data-bbox="193 846 432 981">1 Remove the 5 screws, in the right and the left, which fix the main body with the front grille.</p>  <p data-bbox="193 1323 432 1704">2 Disengage the 3 hooks on the upper part. In case that the hooks are not pressed from above, remove the front panel and then remove the grille while pushing the hook through a clearance between the front grille and the heat exchanger.</p>  <p data-bbox="193 1765 432 1928">3 The front grille can be removed in a manner to pull out the upper part forward and lift up the lower part.</p> 	<ul style="list-style-type: none"> ■ Screw stoppers inside the flap which were equipped in the existing models are not provided. ■ At the upper part there are 2 hooks in the left and the right. ■ Disengage the hooks by pressing knobs with a screwdriver.

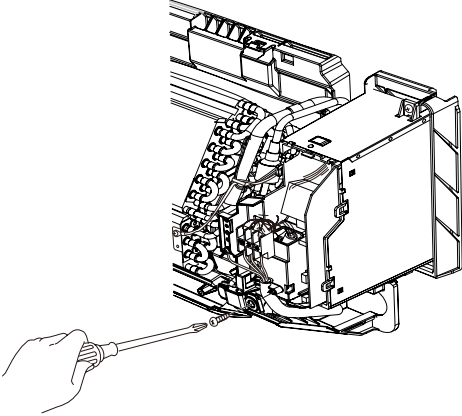
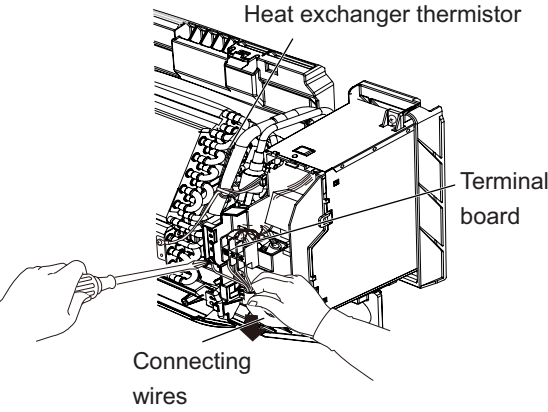
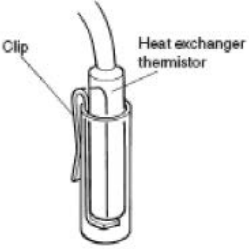
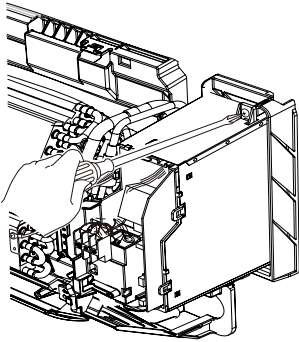
Step	Procedure	Points
6. Remove electrical box		
1	<p>Disconnect the Cable clamp</p> 	<ul style="list-style-type: none"> ■ Pay attention to the direction of the retainer of the thermistor so that the retainer will not touch the harness (same as the existing models.)
2	<p>Remove Temperature Sensor; Disconnect the connection wires. Twist off the earthing screw fixing the evaporator; Pull out the all the wiring terminals</p> 	<p>Take care not to lose the clip of thermistor.</p> 
3	<p>Remove a screw on the electrical box.</p> 	

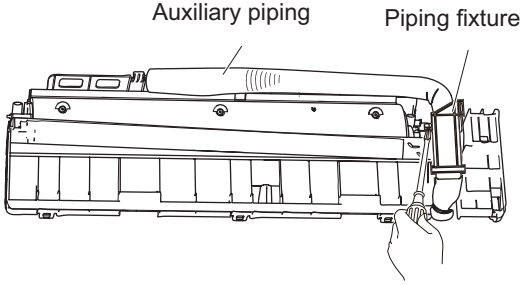
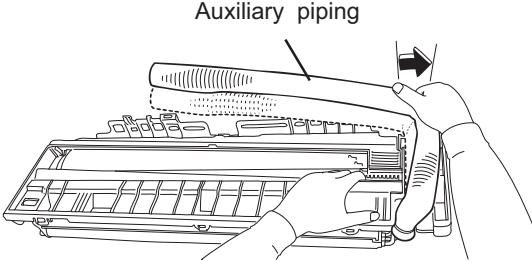
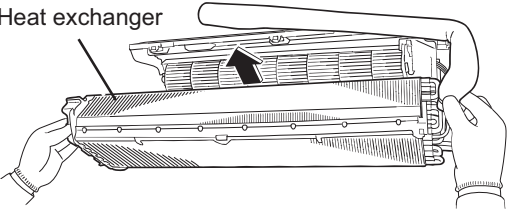
Step	Procedure	Points
7. Remove piping fixture.		
1	<p>Remove Pipe Clamp</p>  <p>Auxiliary piping Piping fixture</p>	
2	<p>Adjust the pipeline slightly</p>  <p>Auxiliary piping</p>	
3	<p>Loosen the screws, in the right and the left, which fix the Evaporator Assy. Remove Evaporator Assy</p>  <p>Heat exchanger</p>	

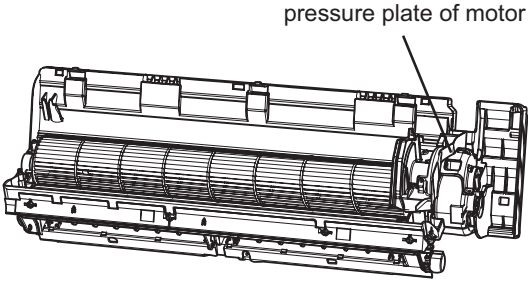
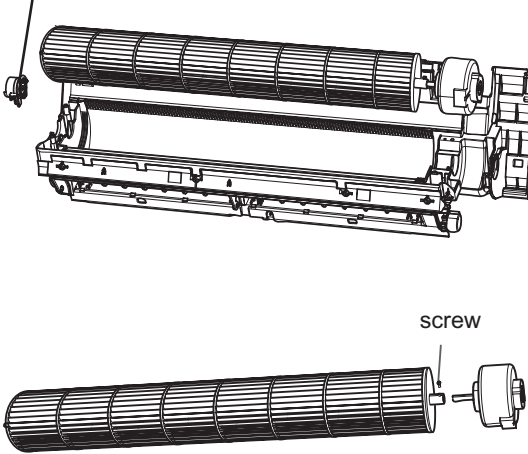
Step	Procedure	Points
8. Remove the pressure plate of motor	<p data-bbox="188 389 483 524">Remove screws of motor press plate and then remove the motor press plate.</p> 	
9. Remove shaft cushion rubber base	<p data-bbox="188 853 459 947">Remove motor, blade and shaft cushion rubber base.</p> <p data-bbox="188 1151 459 1245">Remove screws on cross flow blade and then remove the motor.</p> 	

10.2 Removal Procedure of Outdoor Unit



Warning Be sure to wait for a minimum of 10 minutes after turning off all power supplies before disassembly.

Only take heat pump unit of 18K as an example.

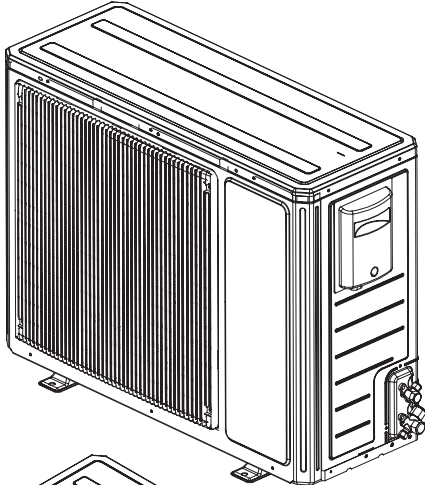
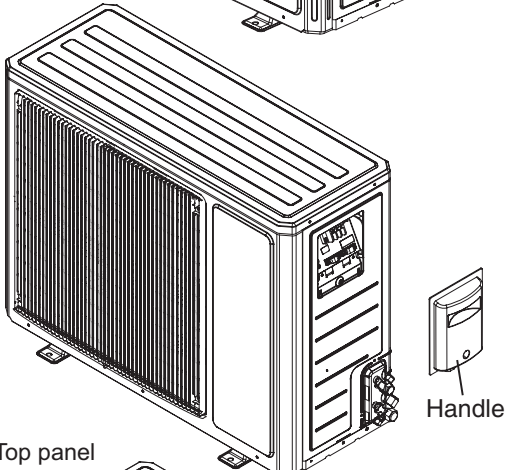
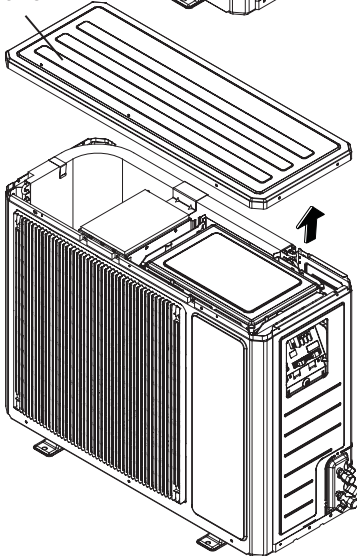
Step	Procedure	Points
1. Remove top cover and handle		
1	<p>Before disassembly.</p> 	
2	<p>Twist off the screws used for fixing the handle, pull the handle upward to remove it.</p>  <p>Top panel</p>	
3	<p>Twist off the screws used for fixing the top cover, pull the top cover upward to remove it.</p> 	

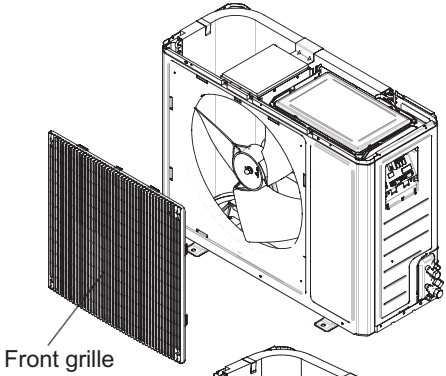
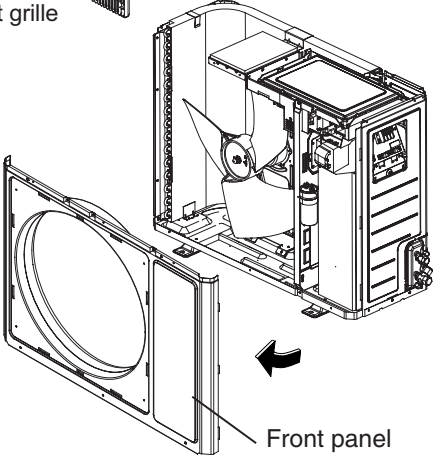
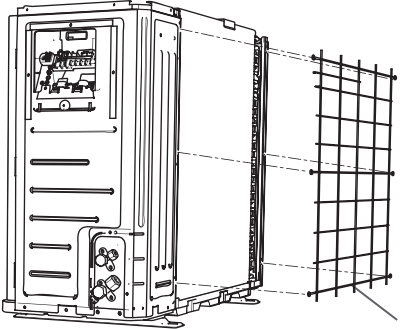
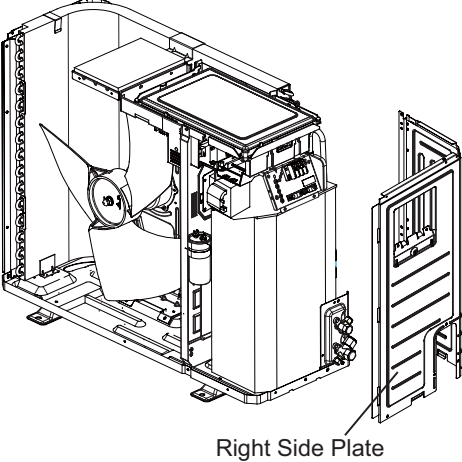
Step	Procedure	Points	
2.Remove front grille and front panel			
1	Remove the screws connecting the front grille and the front panel. Remove the front grille.	 <p>Front grille</p>	<ul style="list-style-type: none"> ■ Lift the front panel and remove it while pushing the right side panel inwards.
2	Twist off the screws fixing the panel, pull it upward, loosen the clasp on the right side, rotate it to the left and then remove the front panel.	 <p>Front panel</p>	
3.Remove right side plate			
1	Remove screws fixing grille, and then remove it.	 <p>Rear Grille</p>	
2	Twist off the screws fixing the right side plate and end plate of condenser and valve support, pull it upward and then remove the right side plate sub-assy.	 <p>Right Side Plate</p>	

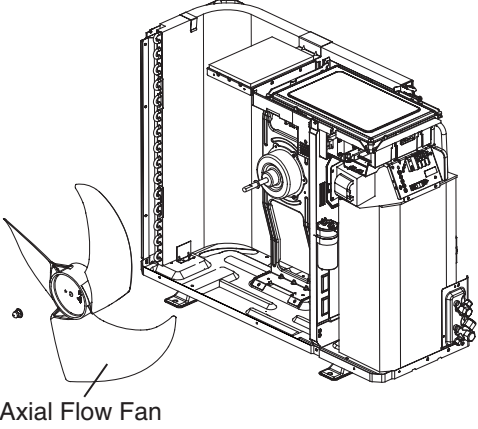
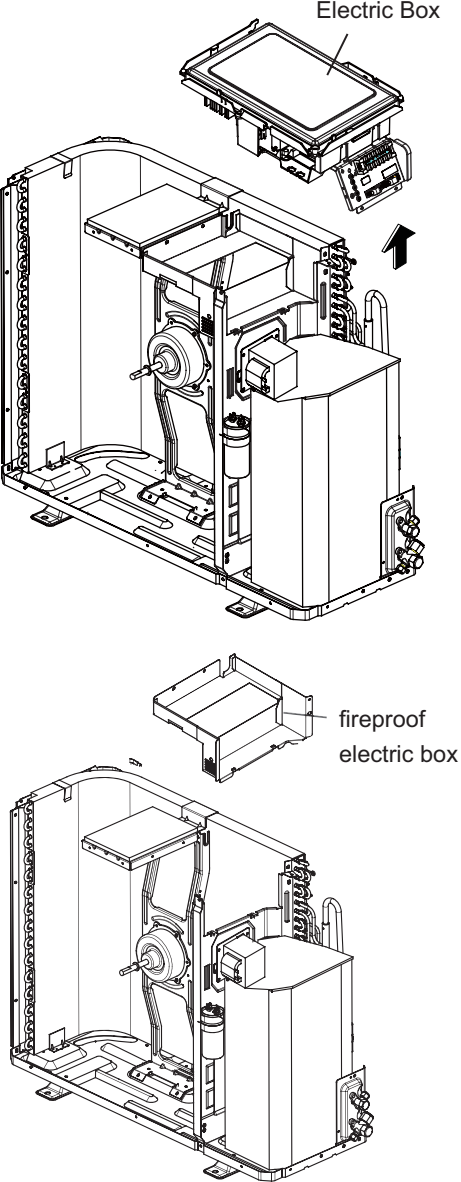
Step	Procedure	Points
4.Remove the axial flow fan	<p>Twist off the nut fixing the blade with wrench and the draw out the axial flow fan.</p>  <p>Axial Flow Fan</p>	<ul style="list-style-type: none"> ■ The screw has reverse winding.
5.Remove Electric Box Assy	<p>1 Pull out motor, compressor temperature sensor, reactor and wiring terminal of capacitor, remove earthing screw on side wiring plate, and remove screws on electric box, and then pull the electric box upwards to remove it.</p>  <p>Electric Box</p> <p>fireproof electric box</p> <p>2 Remove screws fixing fireproof electric box, and then remove the fireproof electric box.</p>	

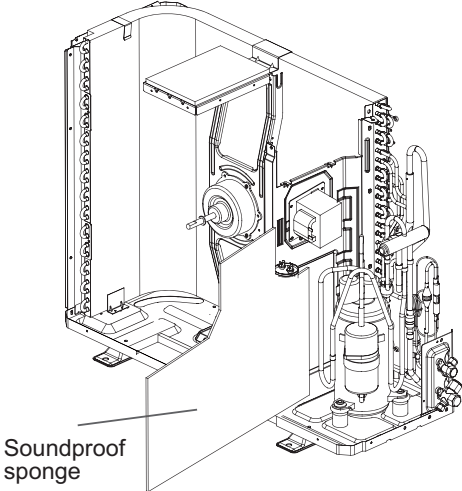
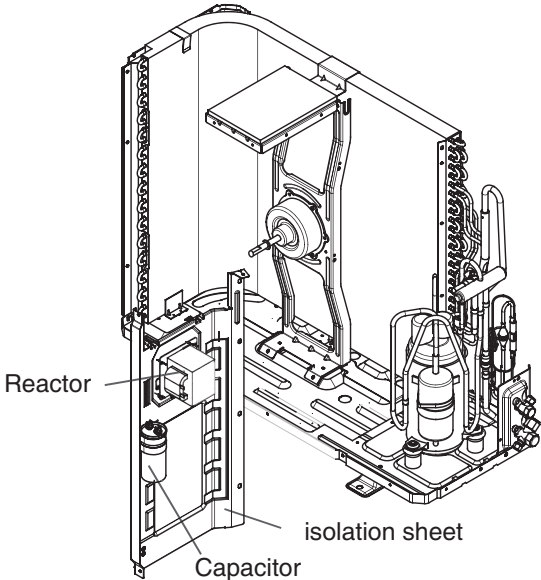
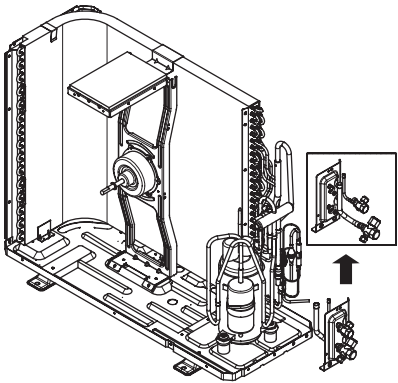
Step	Procedure	Points
<p>6. Remove soundproof sponge</p> <p>Tear up the soundproof sponge carefully.</p>	 <p>Soundproof sponge</p>	<ul style="list-style-type: none"> ■ Since the piping ports on the sound blanket are torn easily, remove the blanket carefully.
<p>7. Remove isolation sheet</p> <p>Remove screws fixing isolation sheet and then remove the isolation sheet.</p>	 <p>Reactor</p> <p>isolation sheet</p> <p>Capacitor</p>	
<p>8. Remove valve</p> <p>Unsolder gas and liquid valves, remove screws fixing valve support and then remove the valve together with the support. Twist off bolts fixing valve and then remove support.</p>		<ul style="list-style-type: none"> ■ Before working, make sure that the refrigerant is empty in the circuit. ■ When unsoldering the soldering joint, wrap the valve with wet cloth completely to avoid the damage to valve due to high temperature. ■ Provide a protective sheet or a steel plate so that the brazing flame cannot influence peripheries.

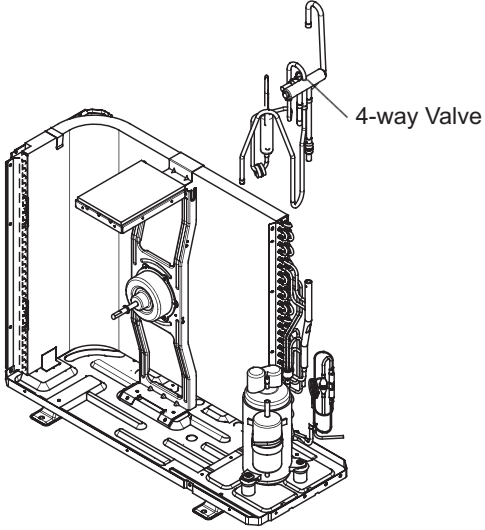
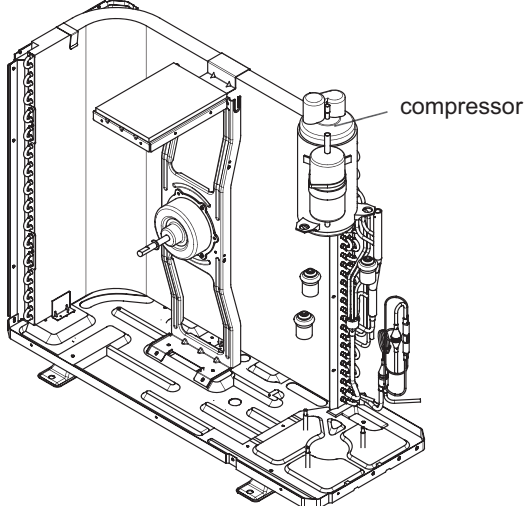
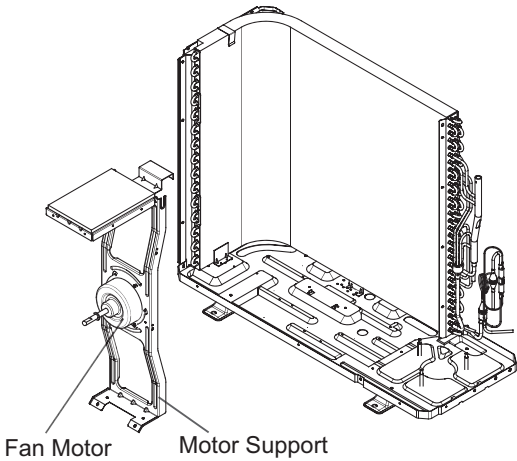
Step	Procedure	Points
9. Remove suction and discharge pipe of compressor	<p data-bbox="199 409 491 577">Loosen the screw of the four way valve coil; Heat up the brazed part and withdraw the piping with pliers.</p> 	<ul style="list-style-type: none"> <li data-bbox="1109 304 1476 405">■ Be careful so as not to burn the compressor terminals or the name plate. <li data-bbox="1101 439 1268 483">⚠ Caution <li data-bbox="1145 506 1476 685">Be careful about the four way valve, pipes and so on, which were heated up by a gas brazing machine, so as not to get burnt your hands.
10. Remove compressor	<p data-bbox="199 963 491 1064">Twist off the three foot nuts on compressor and then remove the compressor.</p> 	
11. Remove motor	<p data-bbox="124 1529 491 1641">1 Remove screws fixing motor support and then remove the motor support.</p> <p data-bbox="124 1769 491 1881">2 Remove 4 screws fixing motor and then remove the motor.</p> 	



Cooper&Hunter International Corporation